

**TYPE 3 SWITCHES**

Type 3 switches are satisfactory for Class A, B or C service. They can be used with any of the light rail tracks (Nos. 34011 through 34031) and with hand propelled or motor driven carriers having 4 inch or 5 inch diameter wheels.

Type 3 switches are available for 2-way right or left hand, 2-way Y or 3-way operation. They have 30 degree outlets on the curve tracks. These switches are provided with 11 inch throw for non-electrified and 2-bar electrified systems and 14 inch throw for 3-bar and 4-bar electrified systems.

Rated loads for Type 3 switches are:

- 2,000 pounds per carrier head.
- 4,000 pounds on the sliding frame and at the outlets of the stationary frame.

Type 3 switches may be electrified with 2, 3 or 4 power conductors of Insul-8-Bar electrification. Standard conductor spacing as indicated in the Electrification Section is used for 2-bar and 3-bar switches; special spacing of conductors is required for 4-bar switches. Elevation of conductors is 6-1/8 inch above the track tread for all Type 3 electrified switches. A wiring harness is furnished on electrified switches to provide power to the conductors in the switch. The harness also serves as a jumper to provide power to the conductors on the incoming tracks.

The sliding frame is a welded assembly consisting of structural angles and straight and curve tracks. The frame is supported on four 3 inch diameter wheels. A stop is provided on the frame to protect the open end of the incoming track when the switch is set against the track. A spring loaded latch holds the switch tracks in alignment with the incoming tracks as the carrier moves through the switch.

The stationary frame is a welded assembly consisting of structural beams and channels. The structural beams serve as runways for the wheels on the sliding frame. Guards are provided on the frame to prevent a carrier from running off the open ends of switch tracks in the event a switch is thrown with a carrier on the sliding frame. Holes are provided in the frame for suspension of the switch. Slotted holes are provided for attaching the incoming tracks.

Type 3 switches are suspended by bolting direct to the superstructure using four 3/4 inch bolts (recommended method) or by four 3/4 inch hanger rods. When suspended from rods, the switch is braced laterally and longitudinally to maintain alignment. Suspension hardware is not included with the switch and is ordered separately.

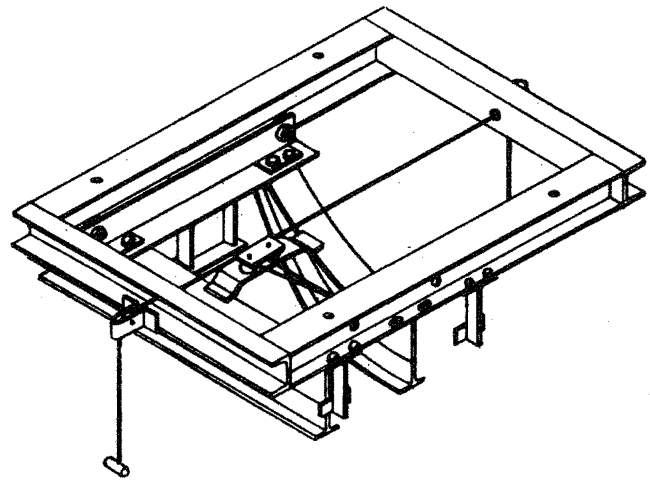

Incoming tracks are bolted to the stationary frame using two 5/8 inch heat treated capscrews, nuts and lockwashers. Slotted holes in the frame help in aligning the system by providing adjustment for the incoming tracks. Hardware is included with the switch end preparations for the incoming tracks.

Type 3 switch drawings and dimensional data are shown on Pages SW-9, SW-10 and SW-11. Switch suspension holes are indicated by the black dots. The drawings illustrate non-electrified switches; electrified switches have the same dimensions and outlines as shown for the non-electrified switches. The drawing and dimensional data for the 2-way right hand and left hand switches on Page SW-9 indicate the dimensions for 2-way right hand switches with 11 inch and 14 inch throw. Dimensions for left hand switches are identical; however, the layout is opposite from that shown and the dimensions are reversed about the centerline of the incoming straight tracks.

Suspension points for the incoming straight tracks are established so that the load on the stationary frame does not exceed its rated load of 4,000 pounds. Preferably, the first suspension point should be as close as possible to the stationary frame. The incoming curve tracks are supported as recommended in the Track & Fittings Section with a minimum of one suspension point on the curve.

Operating handles on the control ropes are located approximately 8 feet below the track. Additional rope can be furnished as required.

Typical switching arrangements and minimum grouping dimensions for Type 3 switches are provided on Pages SW-12 and SW-13.

**TYPE 3 SWITCHES**

**OUTLINE DRAWING OF 2-WAY RIGHT AND LEFT HAND SWITCHES**

The drawing and table indicate the dimensions for 2-way right hand switches with 11" and 14" throw. Dimensions for left hand switches are identical, but the layout is opposite from that shown. (Left hand switch dimensions are reversed about the centerline of the incoming straight tracks.)

The drawing illustrates the non-electrified switch.

Electrified switches have the same dimensions and outline as shown for the non-electrified switch.

The black dots indicate 13/16" diameter holes for switch suspension. Four 3/4" diameter bolts or hanger rods are required to support the switch. When suspended from rods, the switch is braced laterally and longitudinally to maintain alignment.

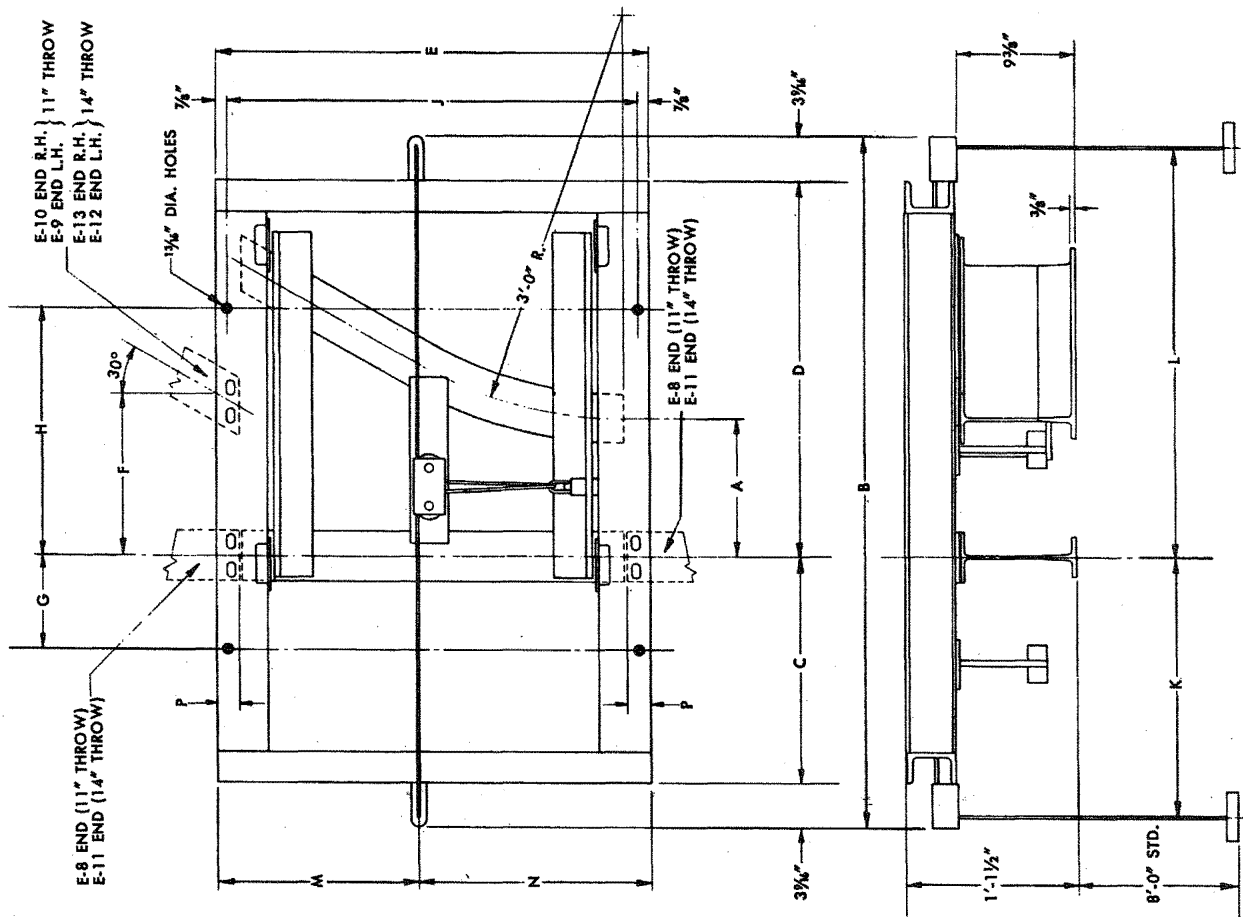

Item Number		Type of Electrification	A (Throw)	B	C	D	E	F	G	H	J	K	L	M	N	P
Right Hand	Left Hand															
41042	41043	Non-Electrified	11 in.	4'-7-1/8	1'-6	2'-6	2'-10	1'-0-7/8	7-3/8	1'-7-3/4	2'-8-1/4	1'-8-5/6	2'-8-5/8	1'-3-3/8	1'-6-5/8	1-13/16
410342	410343	2-Bar Insul-8														
41056	41057	Non-Electrified	14 in.	5'-4-7/8	1'-8-1/2	3'-1-1/4	3'-6-1/4	1'-5-1/8	10-3/8	2'-3-1/8	3'-4-1/2	1'-11-1/8	3'-3-7/8	1'-7-1/4	1'-11	2'-5/8
410356	410357	3-Bar Insul-8														

**TYPE 3 SWITCHES**

OUTLINE DRAWING OF 3-WAY SWITCH

The drawing and table indicate the dimensions for 3-way switches with 11" and 14" throw. The drawing illustrates the non-electrified switch. Electrified switches have the same dimensions and outline as shown for the non-electrified switch.

The black dots indicate 13/16" diameter holes for switch suspension. Four 3/4" diameter bolts or hanger rods are required to support the switch. When suspended from rods, the switch is braced laterally and longitudinally to maintain alignment.

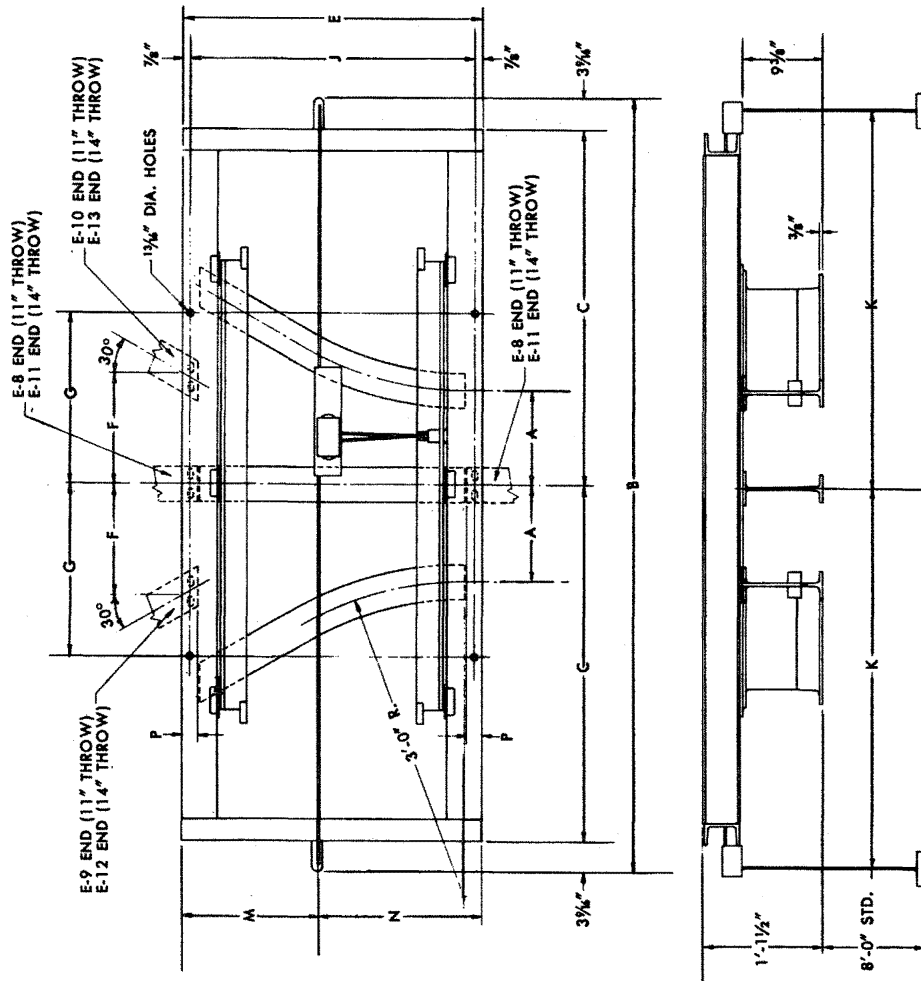

Item Number	Type of Electrification	A (Throw)	B	C	E	F	G	J	K	M	N	P
41044	Non-Electrified	11 in.	7'-4-7/8	3'-4-7/8	2'-10	1'-0-7/8	1'-7-3/4	2'-8-1/4	3'-7-1/2	1'-3-3/8	1'-6-5/8	1-13/16
410344	2-Bar Insul-8											
41058	Non-Electrified	14 in.	9'-1-5/8	4'-3-1/4	3'-6-1/4	1'-5-1/8	1'-7-3/4	3'-4-1/2	4'-5-7/8	1'-7-1/4	1'-11	2-5/8
410358	3-Bar Insul-8											

**TYPE 3 SWITCHES**

OUTLINE DRAWING OF 2-WAY Y SWITCH

The drawing and table indicate the dimensions for 2-way Y switches with 11" and 14" throw. The drawing illustrates the non-electrified switch. Electrified switches have the same dimensions and outline as shown for the non-electrified switch.

The black dots indicate 13/16" diameter holes for switch suspension. Four 3/4" diameter bolts or hanger rods are required to support the switch. When suspended from rods, the switch is braced laterally and longitudinally to maintain alignment.

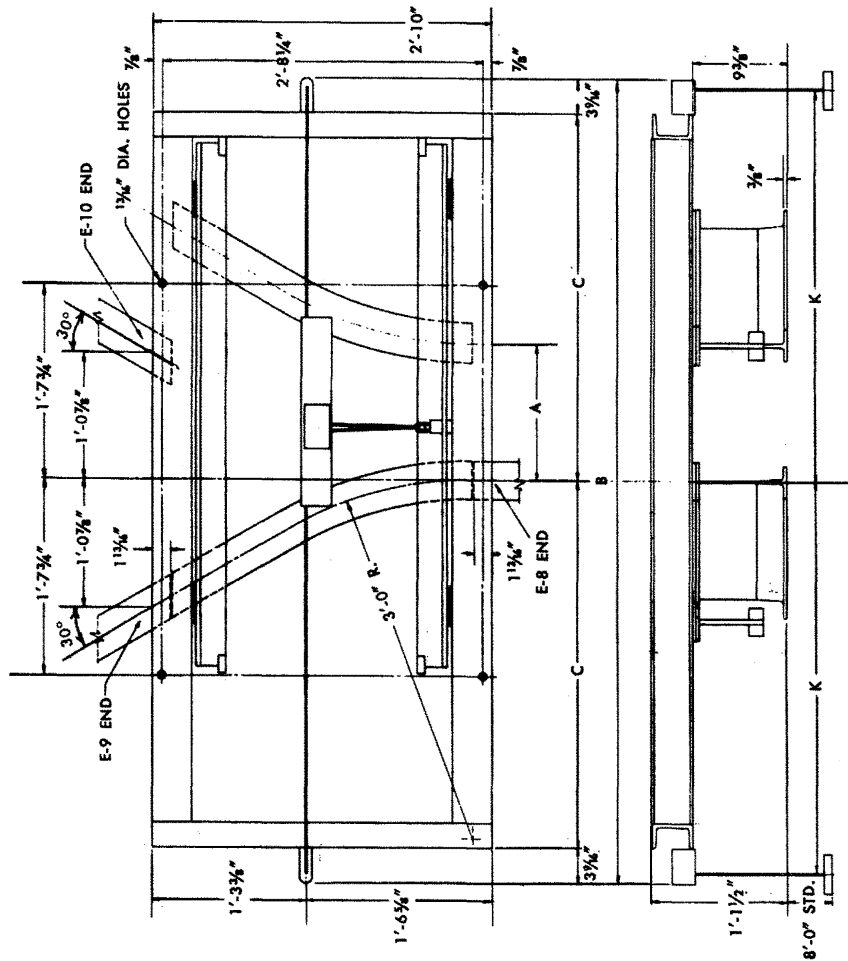

Item Number	Type of Electrification	A (Throw)	B	C	K
41045	Non-Electrified	11 in.	5'-6-7/8	2'-5-7/8	2'-8-3/8
410345	2-Bar Insul-8				
41059	Non-Electrified	14 in.	6'-9-1/8	3'-1	3'-3-1/2
410359	3-Bar Insul-8				

**TYPE 3 SWITCHES**

**TYPICAL SWITCHING ARRANGEMENTS-11" THROW SWITCHES**

The layouts illustrate some of the more frequently used switching arrangements and provide minimum grouping dimensions for the 11 inch throw switches. The table lists dimensions for the more commonly used curve radii.

Close grouping of switches may require outriggers for remote operation of the control ropes to avoid interference between the ropes on one switch and a carrier leaving an adjacent switch. Consult factory for information on outriggers and remote operation.

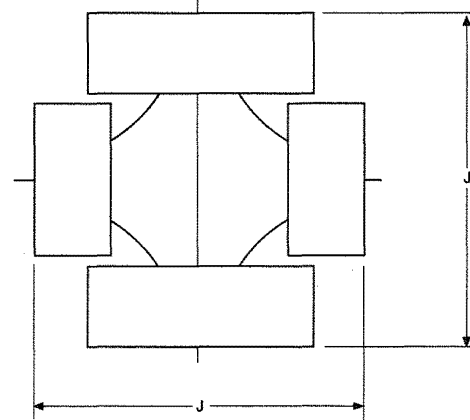
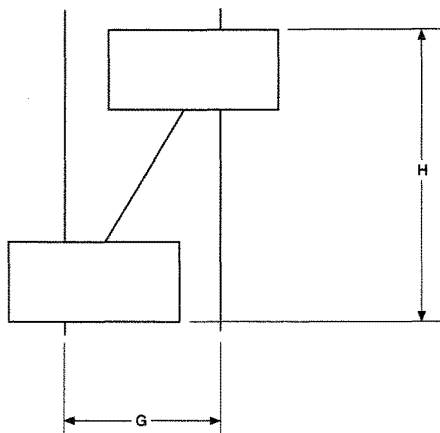
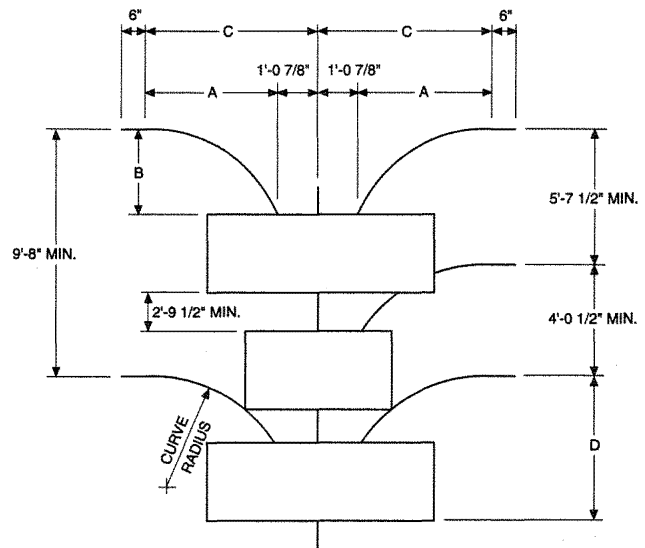
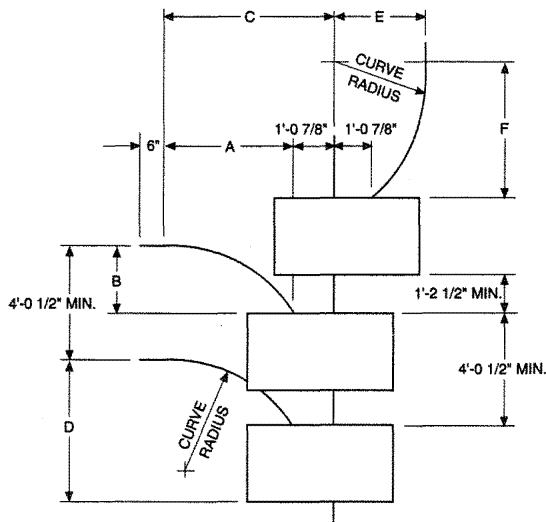

Curve Radius	A	B	C	D	E	F	G	H	J
3'-6	3'-0-3/8	1'-9	4'-1-1/4	4'-7	3'-6	5'-1-11/16	4'-0	8'-10-9/16	-
4'-0	3'-5-9/16	2'-0	4'-6-7/16	4'-10	4'-0	6'-1-11/16	5'-0	10'-7-5/16	10'-8-7/8
6'-0	5'-2-3/8	3'-0	6'-3-1/4	5'-10	6'-0	10'-1-3/4	6'-0	12'-4-1/8	12'-2-1/2
8'-0	6'-11-1/8	4'-0	8'-0	6'-10	8'-0	14'-1-11/16	7'-0	14'-0-7/8	13'-8
10'-0	8'-7-15/16	5'-0	9'-8-13/16	7'-10	10'-0	18'-1-3/4	8'-0	15'-9-11/16	15'-1-5/8

**TYPE 3 SWITCHES**

**TYPICAL SWITCHING ARRANGEMENTS-14" THROW SWITCHES**

The layouts illustrate some of the more frequently used switching arrangements and provide minimum grouping dimensions for the 14 inch throw switches. The table lists dimensions for the more commonly used curve radii.

Close grouping of switches may require outriggers for remote operation of the control ropes to avoid interference between the ropes on one switch and a carrier leaving an adjacent switch. Consult factory for information on outriggers and remote operation.

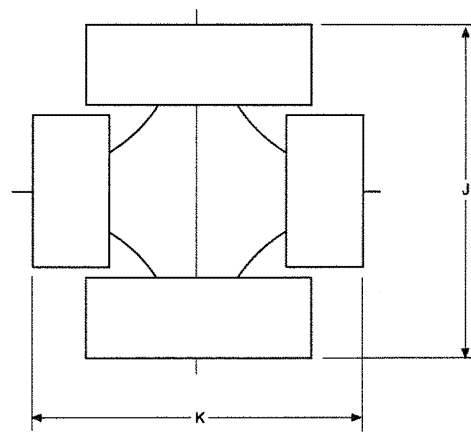
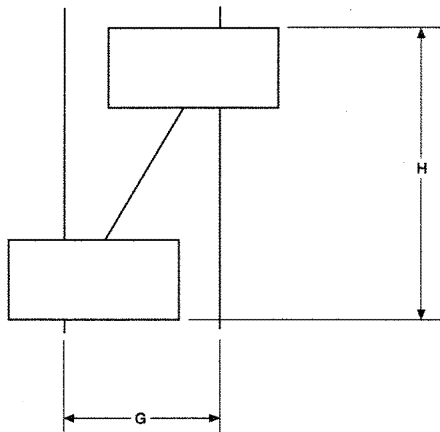
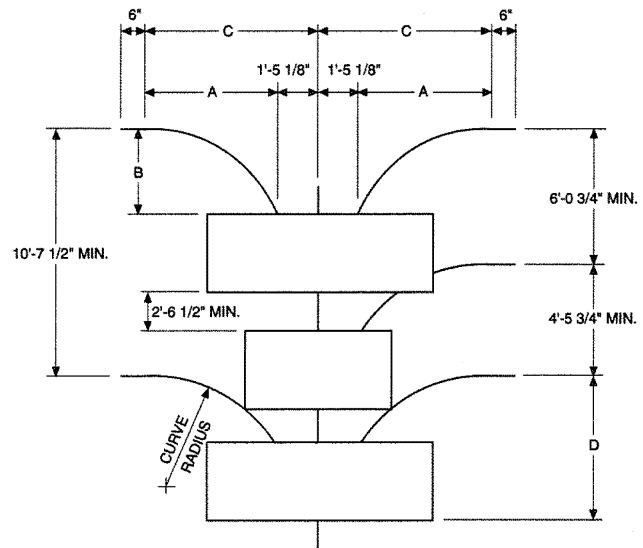
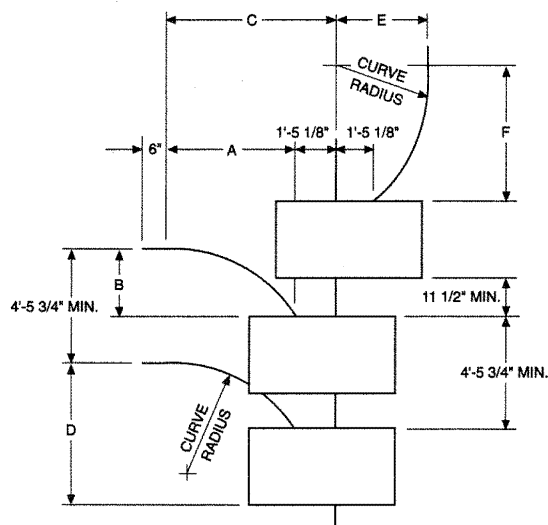

Curve Radius	A	B	C	D	E	F	G	H	J	K
3'-6	3'-0-3/8	1'-9	4'-5-1/2	5'-3-1/4	3'-6	4'-6-3/8	4'-0	9'-0-5/16	-	-
4'-0	3'-5-9/16	2'-0	4'-10-11/16	5'-6-1/4	4'-0	5'-6-5/16	5'-0	10'-9-1/8	-	-
6'-0	5'-2-3/8	3'-0	6'-7-1/2	6'-6-1/4	6'-0	9'-6-3/8	6'-0	12'-5-7/8	13'-7	12'-11
8'-0	6'-11-1/8	4'-0	8'-4-1/4	7'-6-1/4	8'-0	13'-6-5/16	7'-0	14'-2-11/16	15'-0-1/2	14'-4-1/2
10'-0	8'-7-15/16	5'-0	10'-1-1/16	8'-6-1/4	10'-0	17'-6-3/8	8'-0	15'-11-7/16	16'-6-1/8	15'-10-1/8

**TYPE 4 SWITCHES**

Type 4 switches are satisfactory for Class A, B, C or D service. They can be used with any of the light rail tracks (Nos. 34011 through 34031) and with hand propelled or motor driven carriers having 4 inch or 5 inch diameter wheels.

Type 4 switches are available for 2-way right or left hand, 2-way Y or 3-way operation. They have 30 degree outlets on the curve tracks. These switches are provided with 11 inch throw for non-electrified and 2-bar electrified systems and 14 inch throw for 3-bar and 4-bar electrified systems.

Rated loads for Type 4 switches are:

- 2,200 pounds per carrier head.
- 8,000 pounds on the sliding frame and at the outlets of the stationary frame.

Type 4 switches may be electrified with 2, 3 or 4 power conductors of Insul-8-Bar electrification. Standard conductor spacing as illustrated in the Electrification Section is used for 2-bar and 3-bar switches. Special spacing of conductors is required for 4-bar switches. Elevation of conductors is 6-1/8 inch above the track tread for all Type 4 electrified switches. A wiring harness is furnished on electrified switches to provide power to the conductors in the switch. The harness also serves as a jumper to provide power to the conductors on the incoming tracks.

The sliding frame is a welded assembly consisting of structural angles and straight and curve tracks. The frame is supported on four roller assemblies. An energy absorbing stop is provided on the frame to protect the open end of the incoming track when the switch is set against the track. A spring loaded latch holds the switch tracks in alignment with the incoming tracks as the carrier moves through the switch.

The stationary frame is a welded assembly consisting of structural tees, angles and channels. The structural tees serve as runways for the roller assemblies supporting the sliding frame. Guards are provided on the frame to prevent a carrier from running off the open ends of switch tracks in the event a switch is thrown with a carrier on the sliding frame. Holes are provided in the frame for suspension of the switch. Slotted holes are provided for attaching the incoming tracks.

Type 4 switches are suspended by bolting direct to the superstructure using eight 3/4 inch bolts (recommended method) or by four 3/4 inch hanger rods. Hanger rods are used with No. 340127 switch cleats which bolt to the stationary frame. When suspended from rods, the switch is braced laterally and longitudinally to maintain alignment.

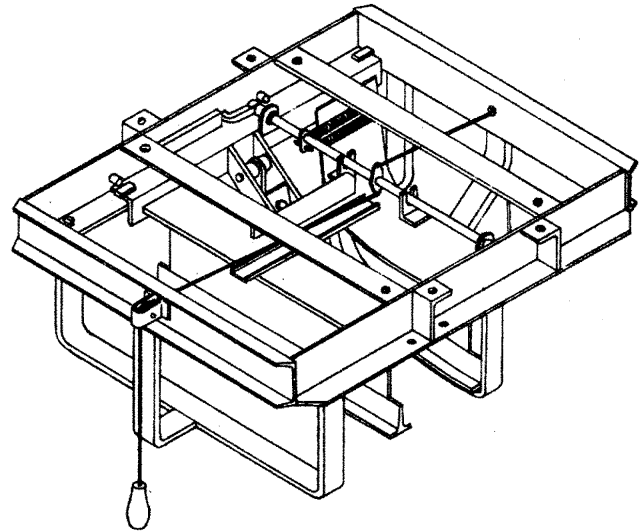

Suspension hardware is not included with the switch and is ordered separately.

Incoming tracks are bolted to the stationary frame using two 3/4 inch heat treated capscrews, nuts and lockwashers. Slotted holes in the frame help in aligning the system by providing adjustment for the incoming tracks. Hardware is included with the switch and preparations for the incoming tracks.

Type 4 switch drawings and dimensional data are shown on Pages SW-15, SW-16 and SW-17. Switch suspension holes are indicated by the black dots. The drawings illustrate non-electrified switches; electrified switches have the same dimensions and outlines as shown for the non-electrified switches. The drawing and dimensional data for the 2-way right hand and left hand switches on Page SW-15 indicate the dimensions for 2-way right hand switches with 11 inch and 14 inch throw. Dimensions for left hand switches are identical; however, the layout is opposite from that shown and the dimensions are reversed about the centerline of the incoming straight tracks.

Suspension points for the incoming straight tracks are established so that the load on the stationary frame does not exceed its rated load of 8,000 pounds. Preferably, the first suspension point should be as close as possible to the stationary frame. The incoming curve tracks are supported as recommended in the Track & Fittings Section with a minimum of one suspension point on the curve.

Operating handles on the control chains are located approximately 8 feet below the track. Additional chain can be furnished as required.

Typical switching arrangements and minimum grouping dimensions for Type 4 switches are provided on Page SW-18.

**TYPE 4 SWITCHES**

**OUTLINE DRAWING OF 2-WAY RIGHT AND LEFT HAND SWITCHES**

The drawing and table indicate the dimensions for 2-way right hand switches with 11" and 14" throw. Dimensions for left hand switches are identical, but the layout is opposite from that shown. (Left hand switch dimensions are reversed about the centerline of the incoming straight tracks.)

The drawing illustrates the non-electrified switch. Electrified switches have the same dimensions and outline as

shown for the non-electrified switch.

The black dots indicate 13/16" diameter holes for switch suspension. Eight 3/4" diameter bolts or four 3/4" diameter hanger rods are required to support the switch. Hanger rods are used with No. 340127 switch cleats which bolt to the stationary frame. When suspended from rods, the switch is braced laterally and longitudinally to maintain alignment.

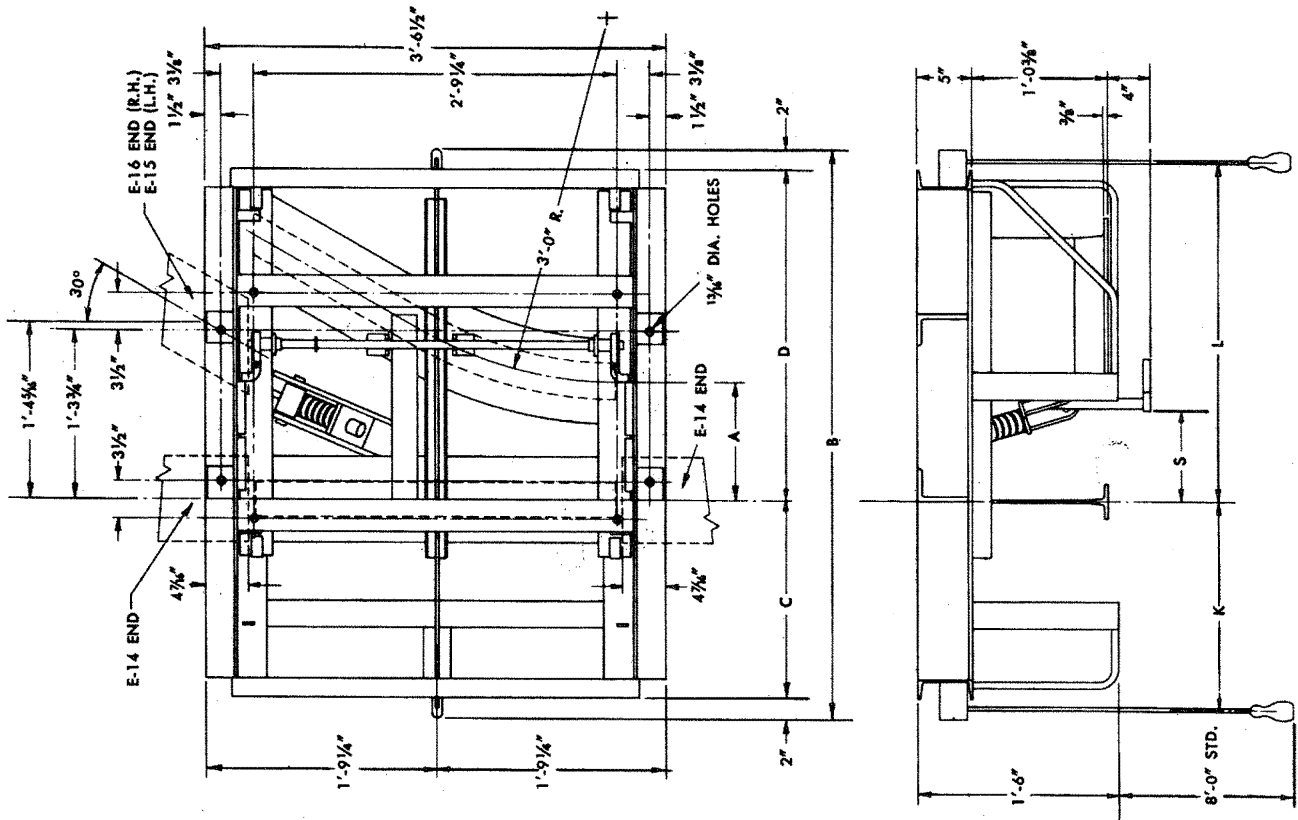

Item Number		Type of	A	B	C	D	K	L	S
Right Hand	Left Hand	Electrification	(Throw)						
41012	41013	Non-Electrified	11 in.	4'-5	1'-6-1/4	2'-6-3/4	1'-7-1/4	2'-7-3/4	8-1/2
410312	410313	2-Bar Insul-8							
41070	41071	Non-Electrified	14 in.	4'-11	1'-9-1/4	2'-9-3/4	1'-10-1/4	2'-10-3/4	10-1/2
410370	410371	3-Bar Insul-8							



**TYPE 4 SWITCHES**

**OUTLINE DRAWING OF 3-WAY SWITCH**

The drawing and table indicate the dimensions for 3-way switches with 11" and 14" throw. The drawing illustrates the non-electrified switch. Electrified switches have the same dimensions and outline as shown for the non-electrified switch.

The black dots indicate 13/16" diameter holes for switch suspension. Twelve 3/4" diameter bolts or six 3/4" diameter hanger rods are required to support the switch. Hanger rods are used with No. 340127 switch cleats which bolt to the stationary frame. When suspended from rods, the switch is braced laterally and longitudinally to maintain alignment.

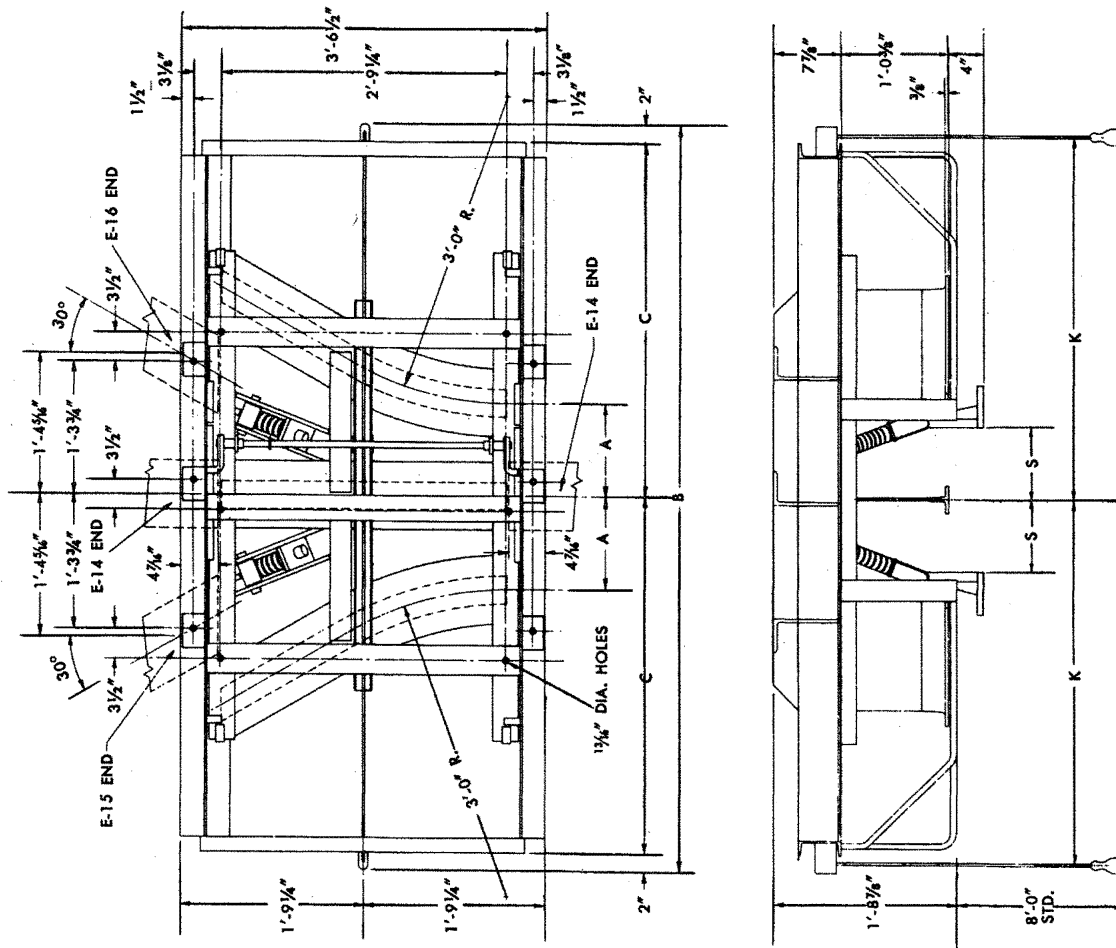

Item Number	Type of Electrification	A (Throw)	B	C	K	S
41016	Non-Electrified	11 in.	7'-3-1/2	3'-5-3/4	3'-6-3/4	8-1/2
410316	2-Bar Insul-8					
41074	Non-Electrified	14 in.	8'-3-1/2	3'-11-3/4	4'-0-3/4	10-1/2
410374	3-Bar Insul-8					

**TYPE 4 SWITCHES**

OUTLINE DRAWING OF 2-WAY Y SWITCH

The drawing and table indicate the dimensions for 2-way Y switches with 11" and 14" throw. The drawing illustrates the non-electrified switch. Electrified switches have the same dimensions and outline as shown for the non-electrified switch.

The black dots indicate 13/16" diameter holes for switch suspension. Ten 3/4" diameter bolts or five 3/4" diameter hanger rods are required to support the switch. Hanger rods are used with No. 340127 switch cleats which bolt to the stationary frame. When suspended from rods, the switch is braced laterally and longitudinally to maintain alignment.

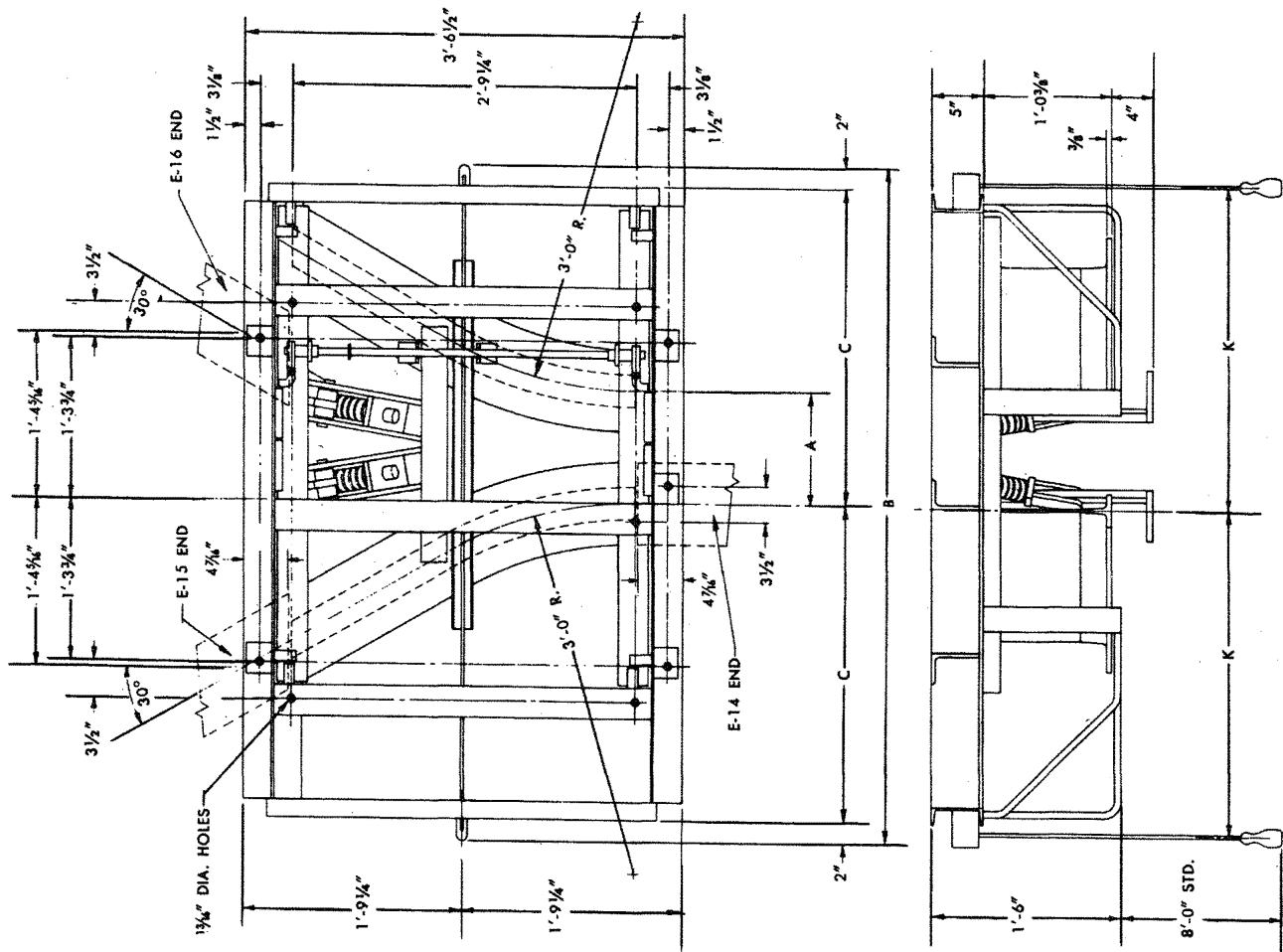

Item Number	Type of Electrification	A (Throw)	B	C	K
41020	Non-Electrified	11 in.	5'-5-1/2	2'-6-3/4	2'-7-3/4
410320	2-Bar Insul-8	14 in.	5'-11-1/2	2'-9-3/4	2'-10-3/4
41076	Non-Electrified				
410376	3-Bar Insul-8				

**TYPE 4 SWITCHES**

**TYPICAL SWITCHING ARRANGEMENTS**

The layouts illustrate some of the more frequently used switching arrangements and provide minimum grouping dimensions. The table lists dimensions for the more commonly used curve radii.

Close grouping of switches may require outriggers for remote operation of the control ropes to avoid interference between the ropes on one switch and a carrier leaving an adjacent switch. Consult factory for information on outriggers and remote operation.

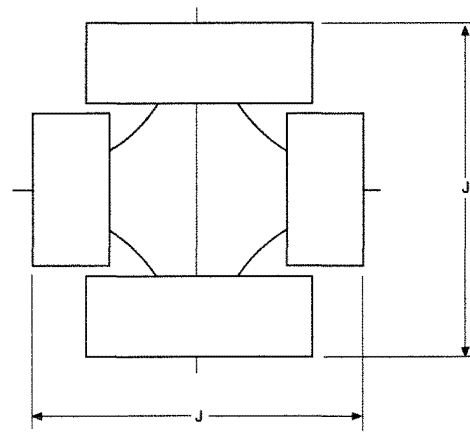
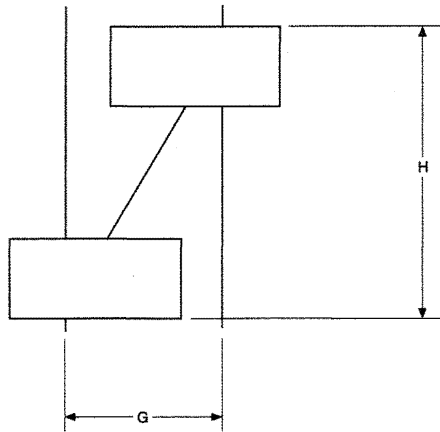
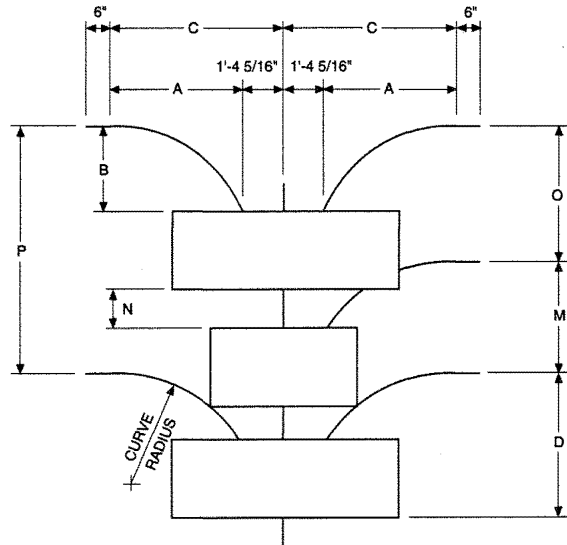
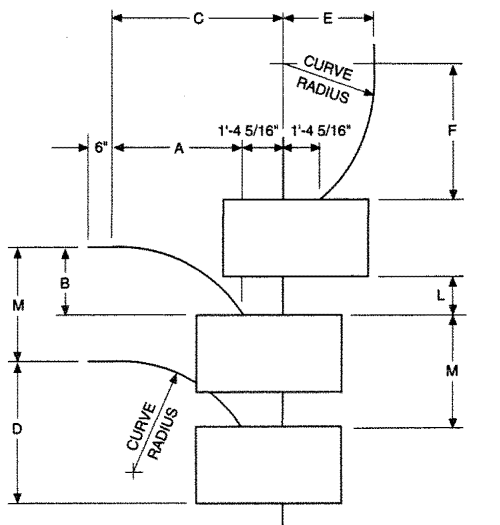

Curve Radius	A	B	C	D	E	F	G	H	J
3'-6	3'-0-3/8	1'-9	4'-4-11/16	5'-3-1/2	3'-6	4'-7-3/4	4'-0	9'-3-5/8	-
4'-0	3'-5-9/16	2'-0	4'-9-7/8	5'-6-1/2	4'-0	5'-7-3/4	5'-0	11'-0-7/16	-
6'-0	5'-2-3/8	3'-0	6'-6-11/16	6'-6-1/2	6'-0	9'-7-3/4	6'-0	12'-9-3/16	14'-2-3/8
8'-0	6'-11-1/8	4'-0	8'-3-7/16	7'-6-1/2	8'-0	13'-7-3/4	7'-0	14'-6	15'-7-7/8
10'-0	8'-7-15/16	5'-0	10'-0-1/4	8'-6-1/2	10'-0	17'-7-3/4	8'-0	16'-2-3/4	17'-1-1/2

**MINIMUM DIMENSIONS**

11" Throw Switches	14" Throw Switches
L = 1'-2-1/2	L = 1'-7-3/4
M = 4'-9	M = 5'-2-1/4
N = 2'-9-1/2	N = 3'-8
O = 6'-4	O = 7'-2-1/2
P = 11'-1	P = 12'-4-3/4

**TYPE 5 SWITCHES**

Type 5 switches are satisfactory for Class A, B, C or D service. They can be used with any of the heavy rail tracks (Nos. 34037 through 34066) and with hand propelled or motor driven carriers having 5 inch or 6-1/2 inch diameter wheels.

Type 5 switches are available for 2-way right or left hand, 2-way Y or 3-way operation. They have 30 degree outlets on the curve tracks. These switches are provided with 11 inch throw for non-electrified and 2-bar electrified systems and 14 inch throw for 3-bar and 4-bar electrified systems.

Rated loads for Type 5 switches are:

- 5,000 pounds per carrier head.
- 12,000 pounds on the sliding frame and at the outlets of the stationary frame.

Type 5 switches may be electrified with 2, 3 or 4 power conductors of Insul-8-Bar electrification. Standard conductor spacing as illustrated in the Electrification Section is used for 2-bar and 3-bar switches. Special spacing of conductors is required for 4-bar switches. Elevation of conductors for Type 5 electrified switches is 6-1/8 inch above the track tread for 5 inch wheel carriers and 7-3/4 inch for 6-1/2 inch wheel carriers. A wiring harness is furnished on electrified switches to provide power to the conductors in the switch. The harness also serves as a jumper to provide power to the conductors on the incoming tracks.

The sliding frame is a welded assembly consisting of structural angles and straight and curve tracks. The frame is supported on four roller assemblies. An energy absorbing stop is provided on the frame to protect the open end of the incoming track when the switch is set against the track. A spring loaded latch holds the switch tracks in alignment with the incoming tracks as the carrier moves through the switch.

The stationary frame is a welded assembly consisting of structural tees, angles and channels. The structural tees serve as runways for the roller assemblies supporting the sliding frame. Guards are provided on the frame to prevent a carrier from running off the open ends of switch tracks in the event a switch is thrown with a carrier on the sliding frame. Holes are provided in the frame for suspension of the switch. Slotted holes are provided for attaching the incoming tracks.

Type 5 switches are suspended by bolting direct to the superstructure using eight 3/4 inch bolts (recommended method) or by four 3/4 inch hanger rods. Hanger rods are used with No. 340127 switch cleats which bolt to the stationary frame. When suspended from rods, the switch is braced

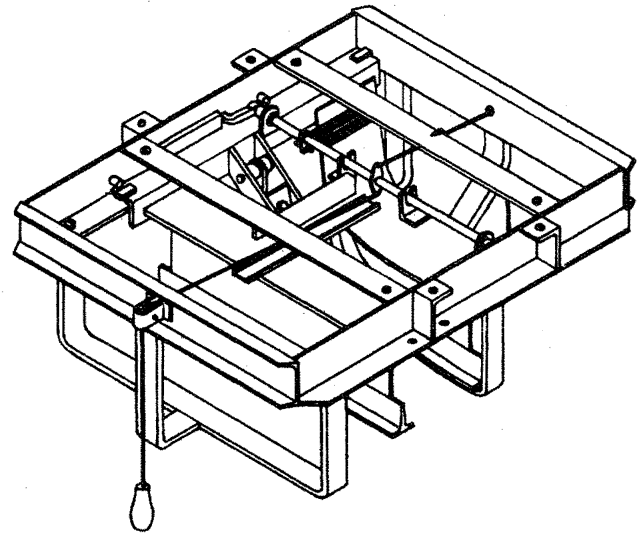

laterally and longitudinally to maintain alignment. Suspension hardware is not included with the switch and is ordered separately.

Incoming tracks are bolted to the stationary frame using two 3/4 inch heat treated capscrews, nuts and lockwashers. Slotted holes in the frame help in aligning the system by providing adjustment for the incoming tracks. Hardware is included with the switch end preparations for the incoming tracks.

Type 5 switch drawings and dimensional data are shown on Pages SW-20, SW-21 and SW-22. Switch suspension holes are indicated by the black dots. The drawings illustrate non-electrified switches; electrified switches have the same dimensions and outlines as shown for the non-electrified switches. The drawing and dimensional data for the 2-way right hand and left hand switches on Page SW-20 indicate the dimensions for 2-way right hand switches with 11 inch and 14 inch throw. Dimensions for left hand switches are identical; however, the layout is opposite from that shown and the dimensions are reversed about the centerline of the incoming straight tracks.

Suspension points for the incoming straight tracks are established so that the load on the stationary frame does not exceed its rated load of 12,000 pounds. Preferably, the first suspension point should be as close as possible to the stationary frame. The incoming curve tracks are supported as recommended in the Track & Fittings Section with a minimum of one suspension point on the curve.

Operating handles on the control chains are located approximately 8 feet below the track. Additional chain can be furnished as required.

Typical switching arrangements and minimum grouping dimensions for Type 5 switches are provided on Page SW-23.

**TYPE 5 SWITCHES**

OUTLINE DRAWING OF 2-WAY RIGHT AND LEFT HAND SWITCHES

The drawing and table indicate the dimensions for 2-way right hand switches with 11" and 14" throw. Dimensions for left hand switches are identical, but the layout is opposite from that shown. (Left hand switch dimensions are reversed about the centerline of the incoming straight tracks.)

The drawing illustrates the non-electrified switch. Electrified switches have the same dimensions and outline as

shown for the non-electrified switch.

The black dots indicate 13/16" diameter holes for switch suspension. Eight 3/4" diameter bolts or four 3/4" diameter hanger rods are required to support the switch. Hanger rods are used with No. 340127 switch cleats which bolt to the stationary frame. When suspended from rods, the switch is braced laterally and longitudinally to maintain alignment.

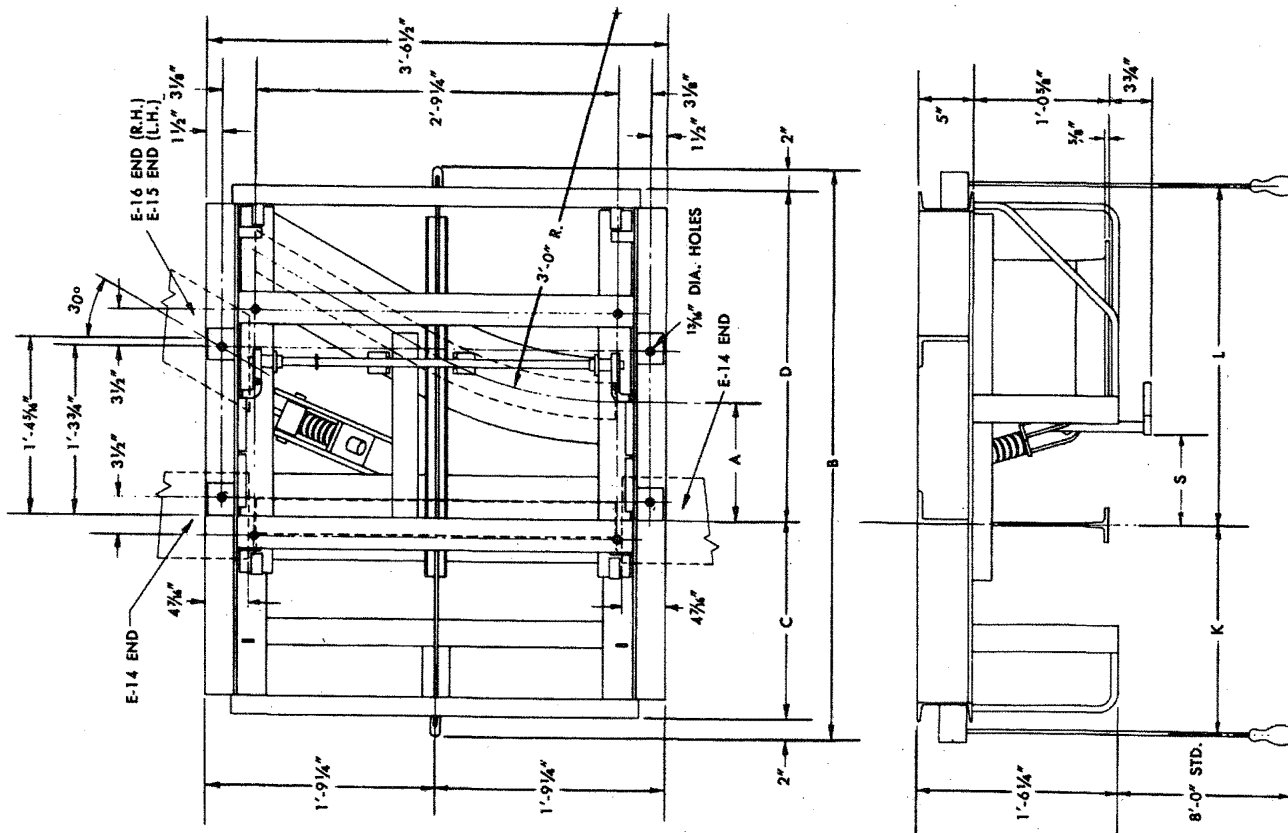

Item Number		Type of	A	B	C	D	K	L	S
Right Hand	Left Hand	Electrification	(Throw)						
41024	41025	Non-Electrified	11 in.	4'-5	1'-6-1/4	2'-6-3/4	1'-7-1/4	2'-7-3/4	8-1/2
410324	410325	2-Bar Insul-8	14 in.	4'-11	1'-9-1/4	2'-9-3/4	1'-10-1/4	2'-10-3/4	10-1/2
41078	41079	Non-Electrified							
410378	410379	3-Bar Insul-8							

**TYPE 5 SWITCHES**

OUTLINE DRAWING OF 3-WAY SWITCH

The drawing and table indicate the dimensions for 3-way switches with 11" and 14" throw. The drawing illustrates the non-electrified switch. Electrified switches have the same dimensions and outline as shown for the non-electrified switch.

The black dots indicate 13/16" diameter holes for switch suspension. Twelve 3/4" diameter bolts or six 3/4" diameter hanger rods are required to support the switch. Hanger rods are used with No. 340127 switch cleats which bolt to the stationary frame. When suspended from rods, the switch is braced laterally and longitudinally to maintain alignment.

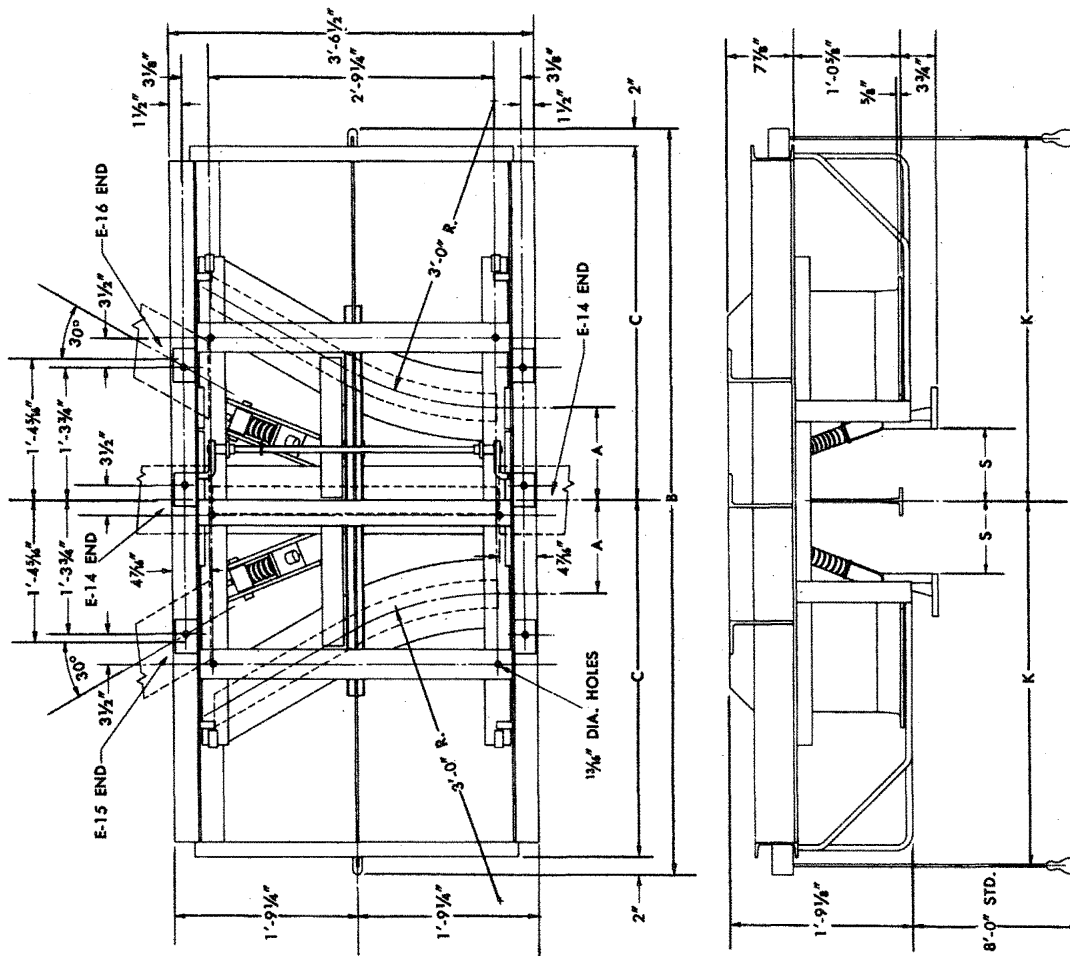

Item Number	Type of Electrification	A (Throw)	B	C	K	S
41028	Non-Electrified	11 in.	7'-3-1/2	3'-5-3/4	3'-6-3/4	8-1/2
410328	2-Bar Insul-8	14 in.	8'-3-1/2	3'-11-3/4	4'-0-3/4	10-1/2
41082	Non-Electrified					
410382	3-Bar Insul-8					

**TYPE 5 SWITCHES**

OUTLINE DRAWING OF 2-WAY Y SWITCH

The drawing and table indicate the dimensions for 2-way Y switches with 11" and 14" throw. The drawing illustrates the non-electrified switch. Electrified switches have the same dimensions and outline as shown for the non-electrified switch.

The black dots indicate 13/16" diameter holes for switch suspension. Ten 3/4" diameter bolts or five 3/4" diameter hanger rods are required to support the switch. Hanger rods are used with No. 340127 switch cleats which bolt to the stationary frame. When suspended from rods, the switch is braced laterally and longitudinally to maintain alignment.

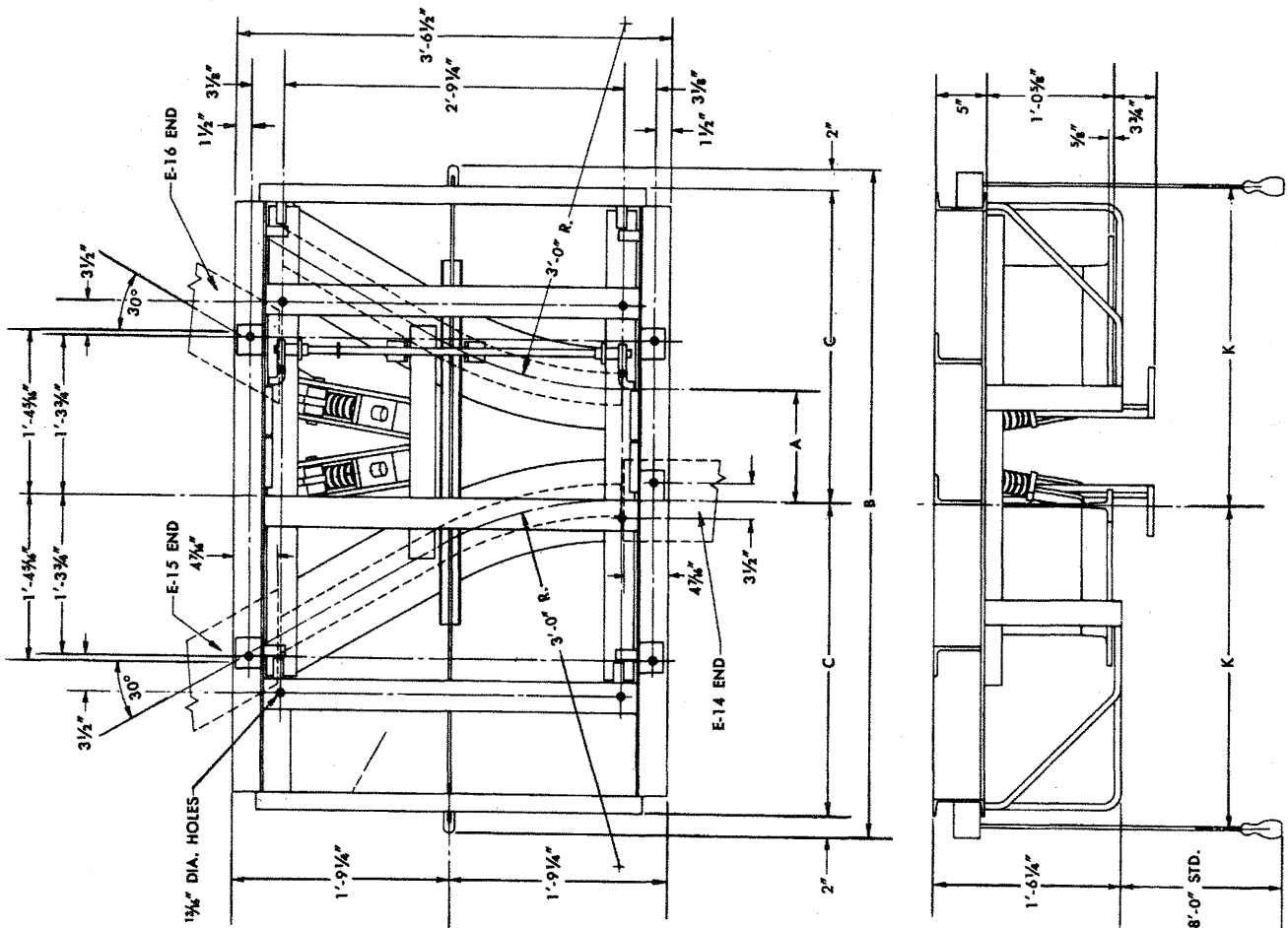

Item Number	Type of Electrification	A (Throw)	B	C	K
41032	Non-Electrified	11 in.	5'-5-1/2	2'-6-3/4	2'-7-3/4
410332	2-Bar Insul-8				
41084	Non-Electrified	14 in.	5'-11-1/2	2'-9-3/4	2'-10-3/4
410384	3-Bar Insul-8				

**TYPE 5 SWITCHES**

TYPICAL SWITCHING ARRANGEMENTS

The layouts illustrate some of the more frequently used switching arrangements and provide minimum grouping dimensions. The table lists dimensions for the more commonly used curve radii.

Close grouping of switches may require outriggers for remote operation of the control ropes to avoid interference between the ropes on one switch and a carrier leaving an adjacent switch. Consult factory for information on outriggers and remote operation.

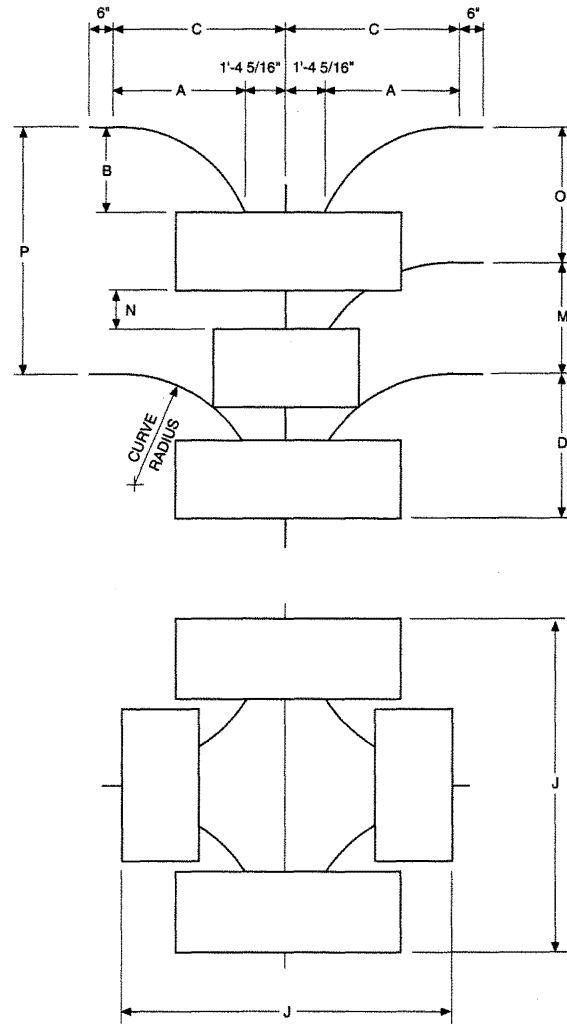
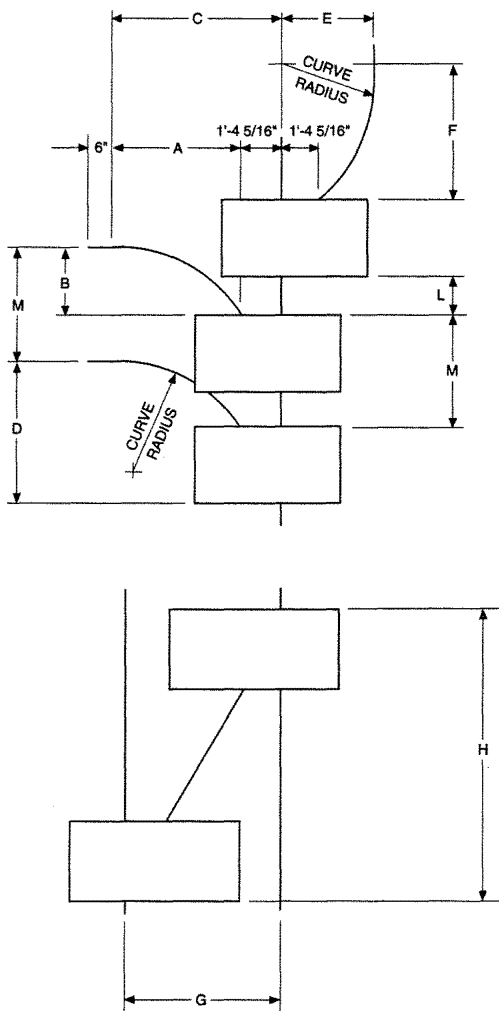

Curve Radius	A	B	C	D	E	F	G	H	J
4'-0	3'-5-9/16	2'-0	4'-9-7/8	5'-6-1/2	4'-0	5'-7-3/4	5'-0	11'-0-7/16	-
6'-0	5'-2-3/8	3'-0	6'-6-11/16	6'-6-1/2	6'-0	9'-7-3/4	6'-0	12'-9-3/16	14'-2-3/8
8'-0	6'-11-1/8	4'-0	8'-3-7/16	7'-6-1/2	8'-0	13'-7-3/4	7'-0	14'-6	15'-7-7/8
10'-0	8'-7-15/16	5'-0	10'-0-1/4	8'-6-1/2	10'-0	17'-7-3/4	8'-0	16'-2-3/4	17'-1-1/2
12'-0	10'-4-11/16	6'-0	11'-9	9'-6-1/2	12'-0	21'-7-3/4	9'-0	17'-11-9/16	18'-7

**MINIMUM DIMENSIONS**

11" Throw Switches	14" Throw Switches
L = 1'-2-1/2	L = 1'-7-3/4
M = 4'-9	M = 5'-2-1/4
N = 2'-9-1/2	N = 3'-8
O = 6'-4	O = 7'-2-1/2
P = 11'-1	P = 12'-4-3/4