

STANDARD SINGLE GIRDER CRANES

Standard, 2-runway, single girder Trambeam cranes are cataloged for rated loads to 10 tons and for spans to 100 feet. Multiple runway cranes are also available; consult factory for assistance on these applications. Selection of 2-runway cranes is made in accordance with the procedure outlined on Page CR-13.

These cranes may be hand propelled, hand racked or motor driven depending on travel distance, frequency of operation, span, elevation and rated load. When used with electric hoists or when motor driven, they are equipped with an electrification system as described on subsequent pages and in the Electrification Section.

Service classifications for cranes are described in ANSI MH 27.1 Specification for Underhung Cranes and Monorail Systems. Cataloged cranes will generally meet the service classification of the hoist and carrier selected to operate on the crane and the requirements of the comparable ANSI MH 27.1 service classification.

For Class D cranes with speeds greater than 200 FPM and all Class E severe duty cranes, consult factory for recommendations.

Complete specifications for bridge girders, girder connections, end trucks, motor driven cranes and crane electrification are described below and on subsequent pages.

BRIDGE GIRDERS

Trambeam track sections as described in the Track & Fitting Section are used for bridge girders. No. 34016 (8-1/2 @ 19.4) is the minimum size girder used on hand propelled cranes. No. 34021 (10 @ 22.2) is the minimum size girder used on motor driven cranes.

Bridge girders with light rails (Nos. 34016 through 34031) are limited to carriers with 4 inch and 5 inch diameter wheels and a maximum carrier head load of 5,000 pounds. Girders with heavy rails (Nos. 34037 through 34079) are limited to a maximum carrier head load of 7,500 pounds.

Bridge girder deflection is limited to 1/450 of the span for cranes having spans of 46' or less. For spans greater than 46', the ratio is reduced so that actual deflection does not exceed 1-1/4 inch.

Brace angles between the bridge girder top flange and end truck are provided on cranes with spans of 20 feet or greater. One brace angle is furnished at each end truck on cranes with spans between 20 feet and 60 feet. Two brace angles are furnished at each end truck on cranes with spans greater than 60 feet.

GIRDER CONNECTIONS

Girder connections to the end trucks utilize key plates on the girder top flange and milled slots in the end truck load bars. The key plates are aligned by an optical instrument and welded into position. A tolerance fit between the key plate and milled slot provides a rigid connection which does not rely on the fit of the attaching hardware in the mounting holes.

END TRUCKS

A complete line of end trucks is available with rated loads from 4,000 to 30,000 pounds. All trucks are available with standard and extended wheelbases. The extended wheelbase trucks are used primarily on long span cranes to provide a minimum 10:1 ratio of span to wheelbase. The use of extended wheelbase trucks on shorter span cranes may also permit the use of a smaller size runway track which is desirable when hook lift is critical. The smaller runway track will also result in a more economical runway cost.

End truck load bars consist of steel channels, plates and bars which are welded into a rigid assembly. After welding, the load bar is machined to control vertical elevations, squareness of trucks and interchangeability of parts. A milled slot, provided at the center of the load bar for girder attachment, serves as the vertical reference for other load bar machining. This results in a uniform dimension between the treads of the runway and bridge girder which is essential to the successful operation of transfer cranes. Lugs are provided in the load bar to limit the drop of the end truck to 1 inch or less in the event of wheel or axle failure.

STANDARD SINGLE GIRDER CRANES

Cranes with trucks having 5 inch diameter wheels operate on all sizes of track. Cranes with trucks having 6-1/2 inch or 8 inch diameter wheels operate on heavy rail track sections only. Certain extended wheelbase trucks are limited in track size by the height of the load bar channels. These runway restrictions are noted on Pages CR-11 and CR-12 and in the crane tables.

MOTOR DRIVEN CRANES

When there are frequent crane movements or long travel distances, motor driven cranes will increase productivity. A motor driven crane improves employee morale and will usually pay for itself in a short period of time.

Motor driven, 2-runway cranes are identical to hand propelled cranes with the addition of tractor drives at each end truck and a motor control system. Multiple runway cranes are driven by two or more tractor drives depending on its length, speed and service classification.

Three tractor drives (Nos. 2408, 2409 and 24010) are available to meet a wide range of applications. All are satisfactory for class D heavy duty service. Complete data on tractor drives, motor control and horsepower requirements are contained in the Tractor Drive Section.

Nominal speeds for single girder cranes are 55 and 90 FPM when No. 24010 drives are used; 100, 125, 150 and 200 FPM when No. 2409 drives are used; and 100, 150, 200, 250 and 300 FPM when No. 2408 drives are used. Other speeds can be furnished.

Wiring and control panels comply with the requirements of OSHA electrical standards and Article 610 of the National Electric Code. Wiring is enclosed in rigid conduit insofar as possible. Crane control panels are furnished with fused motor circuit switch, mainline contactor, motor overcurrent protection, thermal overload relays in 3 phases and NEMA 12 dust-tight enclosures as standard.

CRANE ELECTRIFICATION

Crane electrification consists of a combination of power and control conductors. Power conductors supply current to

the hoist, carrier and any motor operated accessories on the hoist and carrier. Control conductors carry the signals from the operating station to the motor controls.

The number of power conductors depends on the characteristics of the power source. Two power conductors are required for direct current applications. Three power conductors are required for 3 phase alternating current; 4 power conductors are sometimes used for 3 phase alternating current with the 4th conductor used for equipment grounding.

The number of control conductors depends on the location of the operating station, the number of motions being controlled, type of speed control for each motion and control circuit and mainline contactor arrangements.

Three control arrangements are available for motor driven cranes. These arrangements cover the majority of applications and are as follows:

TYPE I control has the operating station on the hoist or carrier. With this arrangement, control conductors are required for the crane motion, mainline contactor and any accessories on the crane. The total number of crane conductors for various combinations of power and crane control used on Type I control is listed in the table on Page CR-8.

TYPE II control has the operating station on the crane. With this arrangement, control conductors are required for the hoist and carrier motions and accessory equipment on the hoist and carrier.

The total number of crane conductors for various combinations of power and hoist and carrier control used on Type II control is listed in the table on Page CR-8.

TYPE III control has 2 operating stations. One is located on the crane and operates the crane motion. The other is located on the hoist or carrier and operates the hoist and carrier motions. With this arrangement, control conductors are not required.

The number of conductors listed in the tables on Page CR-8 for Types I and II control is based on (1) a control circuit arrangement which uses 2 transformers and (2) a mainline contactor arrangement which is operated by a maintained contact push button or toggle switch in the operating station.

STANDARD SINGLE GIRDER CRANES

The control circuit arrangement requires one transformer in the crane control panel and is sized for the mainline contactor, crane control circuit and any crane accessories. A second transformer is supplied with the hoist and is sized for the hoist and carrier control circuits and any accessories on the hoist and carrier. Other control circuit and mainline contactor arrangements may add to the number of control conductors.

Collectors are required for the carrier to pick up current from the power conductors and supply power to the hoist and carrier motors. They are also required for transferring control functions from the operating stations to the control conductors. The number of carrier collectors is generally the same as the number of crane conductors. On transfer crane applications, tandem collector arrangements are usually required

to activate the mainline contactor.

Insul-8-Bar's 90 amp steel conductor is the standard electrification for Trambeam cranes. Complete descriptions of conductor bars, insulating covers, collectors and accessories are in the Electrification Section. Conductor arrangements for single girder cranes are illustrated on Page CR-9.

Open conductors are not recommended as they do not meet the requirements of Article 610 of the National Electric Code.

Single girder cranes, except transfer cranes, may be equipped with festooned electrification; transfer cranes are equipped with rigid conductors to provide continuous power to the hoist and carrier motors as the transfer is made. Festooned electrification is described in the electrification Section.

NUMBER OF CRANE CONDUCTORS						
Type I Control			Type II Control			
Crane Control	3 Phase Alternating Current		Hoist Control	Carrier Control	3 Phase Alternating Current	
	3 Power Conductors	4 Power Conductors			3 Power Conductors	4 Power Conductors
Single Speed	7	8	Single Speed	Single Speed	8	9
2-Speed	8	9	2-Speed	Single Speed	9	10
			5-Speed	Single Speed	12	13
			Single Speed	2-Speed	9	10
			2-Speed	2-Speed	10	11
			5-Speed	2-Speed	13	14

STANDARD SINGLE GIRDER CRANES

CONDUCTOR ARRANGEMENTS

The drawings illustrate the standard arrangement of power and control conductors for motor driven, single girder cranes with Insul-8-Bar electrification. Power conductors (L1, L2 and L3) are 6-1/8 inch above the tread for light rail girders (Nos. 34021 through 34031). Heavy rail girders (Nos. 34037 through 34079) have the power conductors at 6-1/8 inch above the tread for carriers with 4 inch and 5 inch diameter wheels, 7-3/4 inch for carriers with 6-1/2 inch diameter wheels or 9-1/2 inch for carriers with 8 inch diameter wheels.

Control conductors (F, R, X and M) are 1-7/8 inch above the tread when the girder is No. 34056 or less. Cranes with No. 34061 or larger girders have the control conductors at the same elevation as the power conductors.

The conductors and supports shown by solid lines indicate the 7 conductor arrangement used with Type I single speed crane control. The dotted lines indicate the location of additional conductors for other control arrangements.

The illustrated arrangements are satisfactory for transfer cranes only when there are no switches in the spur track. When switches are located in the spur track, control conductors must be lowered to clear the switch stops and guards.

TYPICAL FOR NOS. 34021 THROUGH 34056 GIRDERS

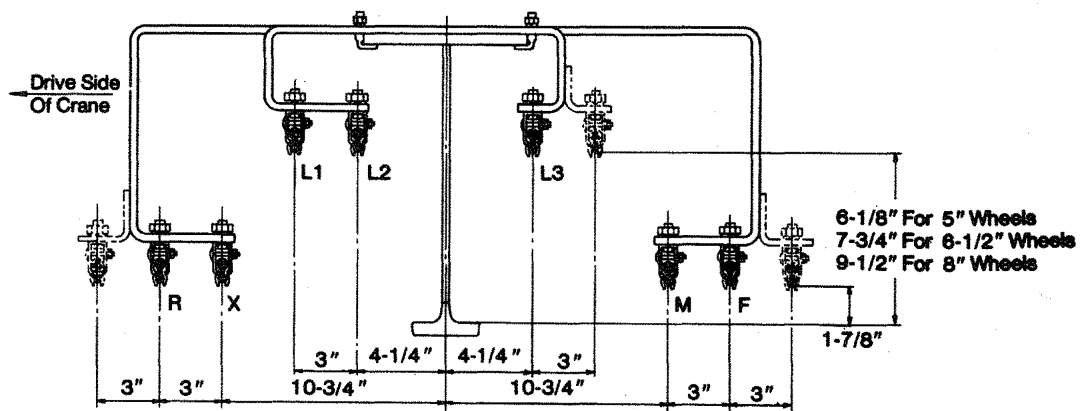

TYPICAL FOR NOS. 34061 THROUGH 34079 GIRDERS

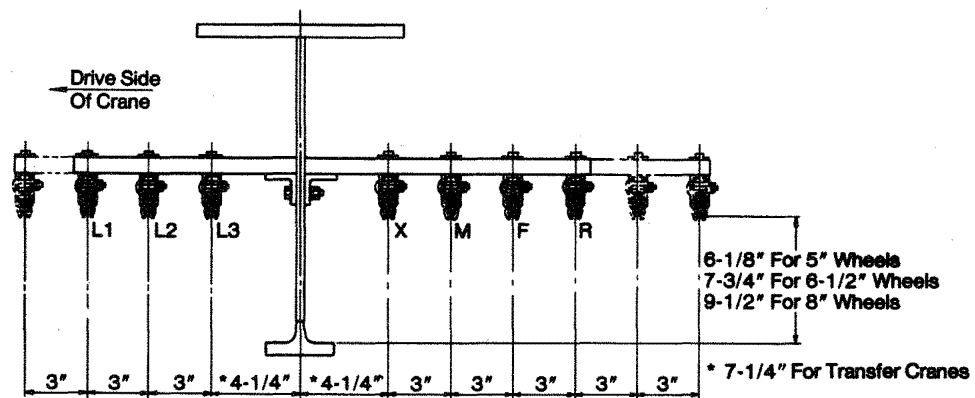

STANDARD SINGLE GIRDER CRANES

BRIDGE GIRDER OVERHANGS

The table lists the minimum, standard and maximum overhangs for single girder cranes. Wherever possible, standard overhangs should be used.

Minimum overhangs for electrified cranes are based on runway electrified with 3 conductor Insul-8-Bar electrification arranged with 2 conductors mounted on the side of the runway away from the overhang.

The maximum overhang should be limited to a length that will not allow the hoist hook to travel beyond the center of the runway when the carrier is against the end stop or the interlock fork. In some cases overhangs greater than the listed maximum can be furnished; consult factory for assistance on these applications.

Minimum overhangs for interlock and discharge ends should be used on transfer cranes to utilize the standard interlock mechanism and to provide for mounting of guide rollers and guides. When overhang is greater than the minimum at the interlock end, the slide rod length may have to be increased to allow the throw out mechanism to clear the end truck load bar.

IMPORTANT: When laying out transfer crane systems or if future installation of an interlock is anticipated, check clearance between extreme of the guide roller or interlock latch and the nearest obstruction.

End Truck Item Number	Minimum						Standard	Maximum	
	Non-Electrified, Hand Propelled Cranes			Electrified, Hand Propelled and Motor Driven Cranes				Light Rail Girders	Heavy Rail Girders
	Plain End	Interlock End*	Discharge End**	Plain End	Interlock End*	Discharge End**			
170304; 170306	5-1/2	9-1/2	1'-2	8-7/8	9-1/2	1'-2	1'-0	1'-6	2'-0
170305; 170307	5-1/2	9-1/2	1'-2	8-7/8	9-1/2	1'-2	1'-0	1'-6	2'-0
170308; 170408	5-1/2	9-1/2	1'-2	8-1/4	9-1/2	1'-2	1'-0	1'-6	2'-0
170309; 170409	5-1/2	9-1/2	1'-2	8-1/4	9-1/2	1'-2	1'-0	1'-6	2'-0
170312	8-3/4	1'-1-1/8	1'-5	8-7/8	1'-1-1/8	1'-5	1'-0	2'-0	2'-6
170313	8-3/4	1'-1-1/8	1'-5	11-3/4	1'-1-1/8	1'-5	1'-0	2'-0	2'-6
170314; 170414	6-1/8	10-1/8	1'-2	8-1/4	10-1/8	1'-2	1'-0	-	2'-6
170315; 170415	6-3/8	10-3/4	1'-2-1/2	8-1/4	10-3/4	1'-2-1/2	1'-0	-	2'-6
170416	7-1/4	10-1/8	1'-2	11-5/8	10-1/8	1'-2	1'-0	-	2'-6
170417	7-1/4	10-3/8	1'-2-1/2	11-3/4	10-3/8	1'-2-1/2	1'-0	-	2'-6
170318; 170418	8-3/4	1'-1-1/8	1'-5	8-3/4	1'-1-1/8	1'-5	1'-0	2'-0	2'-6
170319; 170419	8-5/8	1'-0-5/8	1'-4-1/2	11-3/4	1'-0-5/8	1'-4-1/2	1'-0	2'-0	2'-6
170320; 170420	10	1'-2-3/8	1'-6-1/2	10	1'-2-3/8	1'-6-1/2	1'-0	-	3'-0
170321; 170421	10-1/4	1'-2-5/8	1'-6-1/2	1'-0	1'-2-5/8	1'-6-1/2	1'-0	-	3'-0
170422	1'-0	1'-4-3/8	1'-8-1/2	1'-0	1'-4-3/8	1'-8-1/2	1'-0	-	3'-0
170423	1'-0-1/4	1'-4-5/8	1'-8-1/2	1'-0-1/4	1'-4-5/8	1'-8-1/2	1'-1	-	3'-0

*Minimum bridge girder overhang provides space for mounting of No. 4504 guide roller. Guide roller projects 5-1/2" beyond end of the bridge girder. This projection must be taken into account in laying out transfer crane systems.

**Minimum bridge girder overhang provides space for mounting of No. 4501007 guide roller guide.



STANDARD SINGLE GIRDER CRANES

4-WHEEL END TRUCKS

The drawing illustrates the No. 170308 end truck and is typical for all 4-wheel end trucks. The table indicates the end truck item number, rated load, carrier head, net weight, minimum size runway track and principal dimensions. See Carrier Section for specifications on carrier heads and wheel assemblies.

Load bars consist of steel channels, plates and bars welded into a rigid assembly. After welding, the load bars are machined to control vertical elevations and squareness and to

provide interchangeability. A milled slot, provided at the center of the load bar for girder attachment, also serves as the vertical reference for other load bar machining. Lugs are provided in the load bar to limit the drop of the end truck to 1 inch or less in the event of wheel or axle failure.

The 4,000 and 6,000 pound trucks have bronze washers between the underside of the load bar and carrier head yokes for free swivel of the heads. The 8,000, 13,000 and 15,000 pound trucks have self-aligning bushings in the connection between the carrier heads and the load bar to provide equal wheel loading and free swivel of the heads.

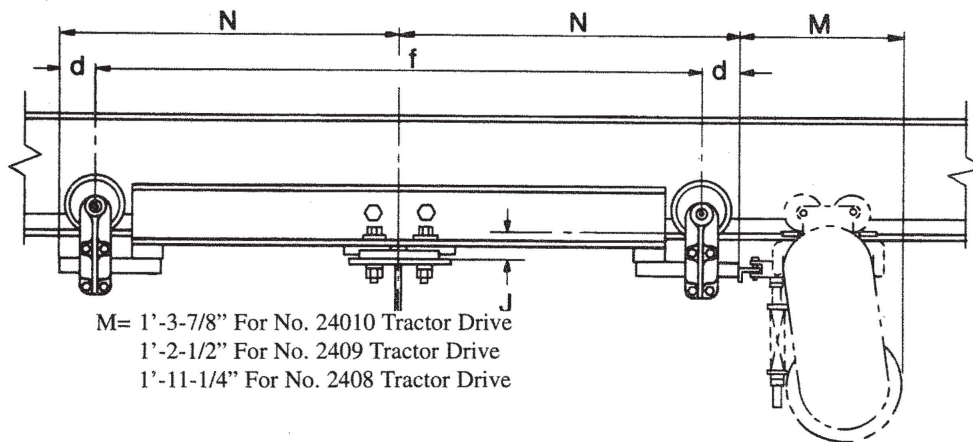

End Truck Item Number	Rated Load (Pounds)	Carrier Head Item No.	Net Weight (Pounds)	Minimum Runway Size	d	f	J	N
170304	4,000	010203	150	34011	3-1/8	4'-0	1-7/8	2'-3-1/8
170305	4,000	010203	193	34011	3-1/8	6'-0	1-7/8	3'-3-1/8
170306	6,000	010205	164	34011	3-1/8	4'-0	1-7/8	2'-3-1/8
170307	6,000	010205	207	34011	3-1/8	6'-0	1-7/8	3'-3-1/8
170308	8,000	010207	179	34011	3-3/4	4'-0	1-7/8	2'-3-3/4
170408	8,000	010208	191	34011	3-3/4	4'-0	1-7/8	2'-3-3/4
170309	8,000	010207	263	34011	3-3/4	6'-0	1-7/8	3'-3-3/4
170408	8,000	010208	275	34011	3-3/4	6'-0	1-7/8	3'-3-3/4
170314	13,000	010209	304	34037	4-1/4	4'-0	2-1/2	2'-4-1/4
170414	13,000	010210	326	34037	4-1/4	4'-0	2-1/2	2'-4-1/4
170315	13,000	010209	487	34037	4-1/4	7'-0	2-1/2	3'-10-1/4
170415	13,000	010210	509	34037	4-1/4	7'-0	2-1/2	3'-10-1/4
170416	15,000	010211	403	34037	4-1/4	4'-0	2-1/2	2'-4-1/4
170417	15,000	010211	586	34037	4-1/4	7'-0	2-1/2	3'-10-1/4

STANDARD SINGLE GIRDER CRANES

8-WHEEL END TRUCKS

The drawing illustrates the No. 170318 end truck and is typical for all 8-wheel end trucks. The table indicates the end truck item number, rated load, carrier head, net weight, minimum size of runway track and principal dimensions. See Carrier Section for specifications on carrier heads and wheel assemblies.

Load bars consist of steel channels, plates and bars welded into a rigid assembly. After welding, the load bars are machined to control vertical elevations and squareness and to provide interchangeability. A milled slot, provided at the

center of the load bar for girder attachment, also serves as the vertical reference for the load bar machining. Lugs are provided in the load bar to limit the drop of the end truck to 1 inch or less in the event of wheel or axle failure.

The 4-wheel carrier load bars are made from steel plate which is machined to control vertical elevations. Self-aligning bushings are used between the carrier load bars and main load bar to provide equal carrier head loading.

The 12,000 pound trucks have bronze washers between the carrier load bar and carrier heads for free swivel of the carrier heads. All other 8-wheel trucks have self-aligning bushings between the carrier heads and carrier load bar to provide equal wheel loading and free swivel of the heads.

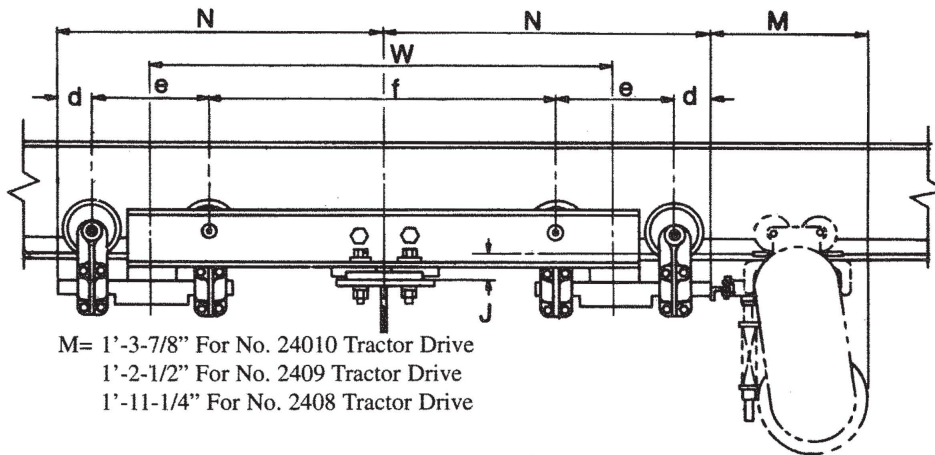

End Truck Item Number	Rated Load (Pounds)	Carrier Head Item No.	Net Weight (Pounds)	Minimum Runway Size	d	e	f	J	N	W
170312	12,000	010205	433	34011	3-1/2	1'-0	3'-8	1-7/8	3'-1-1/2	4'-8
170313	12,000	010205	527	34011	3-1/2	1'-0	7'-0	1-7/8	4'-9-1/2	8'-0
170318	16,000	010207	447	34011	3-3/4	1'-0	3'-8	1-7/8	3'-1-3/4	4'-8
170418	16,000	010208	471	34011	3-3/4	1'-0	3'-8	1-7/8	3'-1-3/4	4'-8
170319	16,000	010207	708	34031	3-3/4	1'-0	7'-0	1-7/8	4'-9-3/4	8'-0
170419	16,000	010208	732	34031	3-3/4	1'-0	7'-0	1-7/8	4'-9-3/4	8'-0
170320	26,000	010209	734	34037	4-1/4	1'-3	4'-6	2-1/2	3'-10-1/4	5'-9
170420	26,000	010210	778	34037	4-1/4	1'-3	4'-6	2-1/2	3'-10-1/4	5'-9
170321	26,000	010209	1,193	34041	4-1/4	1'-3	8'-9	2-1/2	5'-11-3/4	10'-0
170421	26,000	010210	1,237	34041	4-1/4	1'-3	8'-9	2-1/2	5'-11-3/4	10'-0
170422	30,000	010211	1,026	34037	4-1/4	1'-3	4'-6	2-1/2	3'-10-1/4	5'-9
170423	30,000	010211	1,440	34041	4-1/4	1'-3	8'-0	2-1/2	5'-7-1/4	9'-3

SELECTION OF STANDARD SINGLE GIRDER CRANES

Standard single girder, 2-runway cranes are tabulated on subsequent pages by (1) means of propulsion, (2) number of end truck wheels, (3) rated load and (4) span. The tables provide a simple means for crane selection and indicate the crane code number, net weight, minimum runway size and clearance dimensions. End truck wheelbase dimensions are also provided to assist in determining the runway size.

Hand propelled cranes are listed for rated loads of 1, 2 and 3 tons and spans from 12'-0 to 40'-0. Cranes with greater rated load and span or with bridge girder tread elevations greater than 12'-0 are not recommended for hand propelling. Motor driven cranes are listed for rated loads of 1, 2, 3, 5, 7-1/2 and 10 tons.

Crane rated loads are based on a carrier design load which is adequate for most applications. The carrier design load includes: (1) hoist and carrier weights, (2) rated load and (3) 15% impact allowance. The design load is shown in the tables.

Crane selection is made by:

STEP 1 - Determine actual carrier load (weights of hoist and carrier selected for the crane, rated load and impact allowance, if applicable).

STEP 2 - Select crane from table providing actual load is no greater than the design load.

If the actual load exceeds the design load, it is necessary to calculate the girder and end truck loads and select the components on the basis of the calculated loads

Crane code numbers indicate the means of propulsion, type of electrification, bridge girder size, type of end truck and overall length of bridge girder. Page CR-2 provides a complete explanation of the crane code numbering system.

Net weights of hand propelled cranes are for cranes with 3 conductors of Insul-8-Bar. Net weights of motor driven cranes are for cranes with 7 conductors of Insul-8-Bar and motorization with No. 2409 tractor drives. Cranes with No. 2408 drives are approximately 400 pounds heavier than the weight indicated in the tables. Cranes with No. 24010 drives are approximately 120 pounds less than the weight indicated in the tables.

Cranes are listed with an overall length based on a nominal span between runway tracks and 1'-0 nominal girder overhangs. See Page CR-10 for minimum, maximum and standard overhangs when determining the crane span and overall length.

A clearance drawing is provided on the page facing each crane table. The drawings for motor driven cranes locate the control panel elevation for crane with Nos. 34021 through 34056 girders. The horizontal spacing of the panel varies with the type of control and collector arrangement. Consult factory for this dimension if the possibility exists for interference between the panel and building, lights, etc.

Dimension J is the distance between the running treads of the runway track and bridge girder and is shown in the crane tables for full depth bridge girders. The dimension will decrease and provide closer headroom if the bridge girder is coped or low headroom end truck construction is used. See Pages CR-37 and CR-38 for data on coped bridge girders and low headroom cranes.

STANDARD SINGLE GIRDER CRANES

CLEARANCE DRAWING FOR HAND PROPELLED CRANES WITH 4-WHEEL END TRUCKS

The drawing illustrates the clearances of a hand propelled crane with 4-wheel end trucks and 3 conductor Insul-8-Bar electrification. Clearances of a non-electrified crane are the same except there is no collector overhang on the end truck. On electrified cranes, the runway end stops at the collector end of the crane should be located a sufficient distance from

the end of the runway to prevent the collectors from leaving the conductors. When 2 or more electrified cranes operate on the same runway, cranes should be equipped with extension bumpers to prevent the collectors from hitting.

Dimensions f, J, K and N are shown on the facing page. To determine dimensions A, B and C refer to the appropriate clearance drawing in the Carrier Section for the hoist and carrier selected for the crane. See Page CR-10 for minimum, maximum and standard bridge girder overhangs.

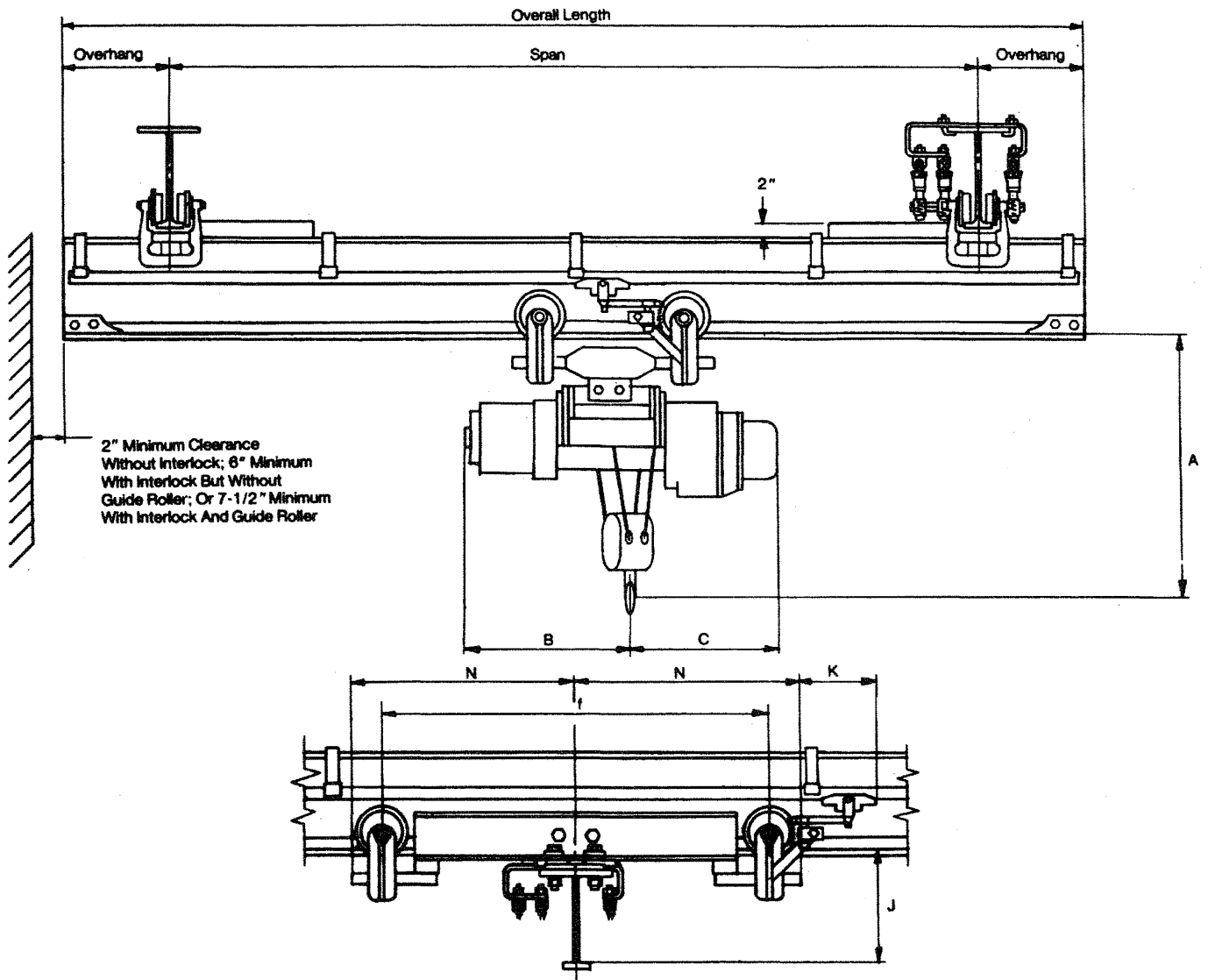

STANDARD SINGLE GIRDER CRANES

HAND PROPELLED CRANES WITH 4-WHEEL END TRUCKS

HAND PROPELLED CRANES WITH 4-WHEEL END TRUCKS										
Rated Load (Tons)	Design Load (Lbs.)	Crane Code Number	Net Weight (Lbs.)	Span (Ft.)	Overall Length (Ft.)	Minimum Runway Size	f	J	K	N
1	2920	HW16S204X14	673	12	14	34011	4'-0	10	9-5/8	2'-3-1/8
		HW16S204X16	722	14	16	34011	4'-0	10	9-5/8	2'-3-1/8
		HW16S204X18	770	16	18	34011	4'-0	10	9-5/8	2'-3-1/8
		HW16S204X20	818	18	20	34011	4'-0	10	9-5/8	2'-3-1/8
		HW16S204X22	901	20	22	34011	4'-0	10	9-5/8	2'-3-1/8
		HW21S204X24	1016	22	24	34011	4'-0	11-1/2	9-5/8	2'-3-1/8
		HW21S204X26	1071	24	26	34011	4'-0	11-1/2	9-5/8	2'-3-1/8
		HW21S204X28	1125	26	28	34011	4'-0	11-1/2	9-5/8	2'-3-1/8
		HW26S204X30	1301	28	30	34011	4'-0	1'-1	9-5/8	2'-3-1/8
		HW26S204X32	1364	30	32	34011	4'-0	1'-1	9-5/8	2'-3-1/8
		HW31S204X34	1528	32	34	34011	4'-0	1'-2-1/2	9-5/8	2'-3-1/8
		HW31S204X36	1596	34	36	34011	4'-0	1'-2-1/2	9-5/8	2'-3-1/8
		HW41S204X38	2006	36	38	34011	4'-0	1'-3-1/4	9-5/8	2'-3-1/8
		HW46S204X40	2252	38	40	34011	4'-0	1'-5-1/4	9-5/8	2'-3-1/8
HW46S204X42	2347	40	42	34011	4'-0	1'-5-1/4	9-5/8	2'-3-1/8		
2	5330	HW16S206X14	701	12	14	34011	4'-0	10	10-1/8	2'-3-1/8
		HW16S206X16	750	14	16	34011	4'-0	10	10-1/8	2'-3-1/8
		HW16S206X18	797	16	18	34011	4'-0	10	10-1/8	2'-3-1/8
		HW21S206X20	902	18	20	34011	4'-0	11-1/2	10-1/8	2'-3-1/8
		HW21S206X22	991	20	22	34011	4'-0	11-1/2	10-1/8	2'-3-1/8
		HW26S206X24	1143	22	24	34011	4'-0	1'-1	10-1/8	2'-3-1/8
		HW26S206X26	1205	24	26	34011	4'-0	1'-1	10-1/8	2'-3-1/8
		HW31S206X28	1351	26	28	34011	4'-0	1'-2-1/2	10-1/8	2'-3-1/8
		HW31S206X30	1413	28	30	34011	4'-0	1'-2-1/2	10-1/8	2'-3-1/8
		HW41S206X32	1776	30	32	34011	4'-0	1'-3-1/4	10-1/8	2'-3-1/8
		HW41S206X34	1862	32	34	34011	4'-0	1'-3-1/4	10-1/8	2'-3-1/8
		HW41S206X36	1948	34	36	34011	4'-0	1'-3-1/4	10-1/8	2'-3-1/8
		HW46S206X38	2186	36	38	34011	4'-0	1'-5-1/4	10-1/8	2'-3-1/8
		HW46S206X40	2280	38	40	34011	4'-0	1'-5-1/4	10-1/8	2'-3-1/8
HW51S208X42	2724	40	42	34011	4'-0	1'-7-1/4	9-3/8	2'-3-3/4		
3	8030	HW16S208X14	737	12	14	34011	4'-0	10	9-3/8	2'-3-3/4
		HW21S208X16	831	14	16	34011	4'-0	11-1/2	9-3/8	2'-3-3/4
		HW21S208X18	884	16	18	34011	4'-0	11-1/2	9-3/8	2'-3-3/4
		HW26S208X20	1020	18	20	34011	4'-0	1'-1	9-3/8	2'-3-3/4
		HW26S208X22	1117	20	22	34011	4'-0	1'-1	9-3/8	2'-3-3/4
		HW31S208X24	1252	22	24	34011	4'-0	1'-2-1/2	9-3/8	2'-3-3/4
		HW31S208X26	1315	24	26	34011	4'-0	1'-2-1/2	9-3/8	2'-3-3/4
		HW41S208X28	1640	26	28	34011	4'-0	1'-3-1/4	9-3/8	2'-3-3/4
		HW41S208X30	1726	28	30	34011	4'-0	1'-3-1/4	9-3/8	2'-3-3/4
		HW46S214X32	2191	30	32	34037	4'-0	1'-5-7/8	8-1/2	2'-4-1/4
		HW46S214X34	2285	32	34	34037	4'-0	1'-5-7/8	8-1/2	2'-4-1/4
		HW51S214X36	2652	34	36	34037	4'-0	1'-7-7/8	8-1/2	2'-4-1/4
		HW51S214X38	2759	36	38	34037	4'-0	1'-7-7/8	8-1/2	2'-4-1/4
		HW56S214X40	3055	38	40	34037	4'-0	1'-9-7/8	8-1/2	2'-4-1/4
HW56S214X42	3174	40	42	34037	4'-0	1'-9-7/8	8-1/2	2'-4-1/4		

STANDARD SINGLE GIRDER CRANES

CLEARANCE DRAWING FOR HAND PROPELLED CRANES WITH 8-WHEEL END TRUCKS

The drawing illustrates the clearances of a hand propelled crane with 8-wheel end trucks and 3 conductor Insul-8-Bar electrification. Clearances of a non-electrified crane are the same except there is no collector overhang on the end truck. On electrified cranes, the runway end stops at the collector end of the crane should be located a sufficient distance from

the end of the runway to prevent the collectors from leaving the conductors. When 2 or more electrified cranes operate on the same runway, cranes should be equipped with extension bumpers to prevent the collectors from hitting.

Dimensions e, f, J, K, N and W are shown on the facing page. To determine dimensions A, B and C, refer to the appropriate clearance drawing in the Carrier Section for the hoist and carrier selected for the crane. See Page CR-10 for minimum, maximum and standard bridge girder overhangs.

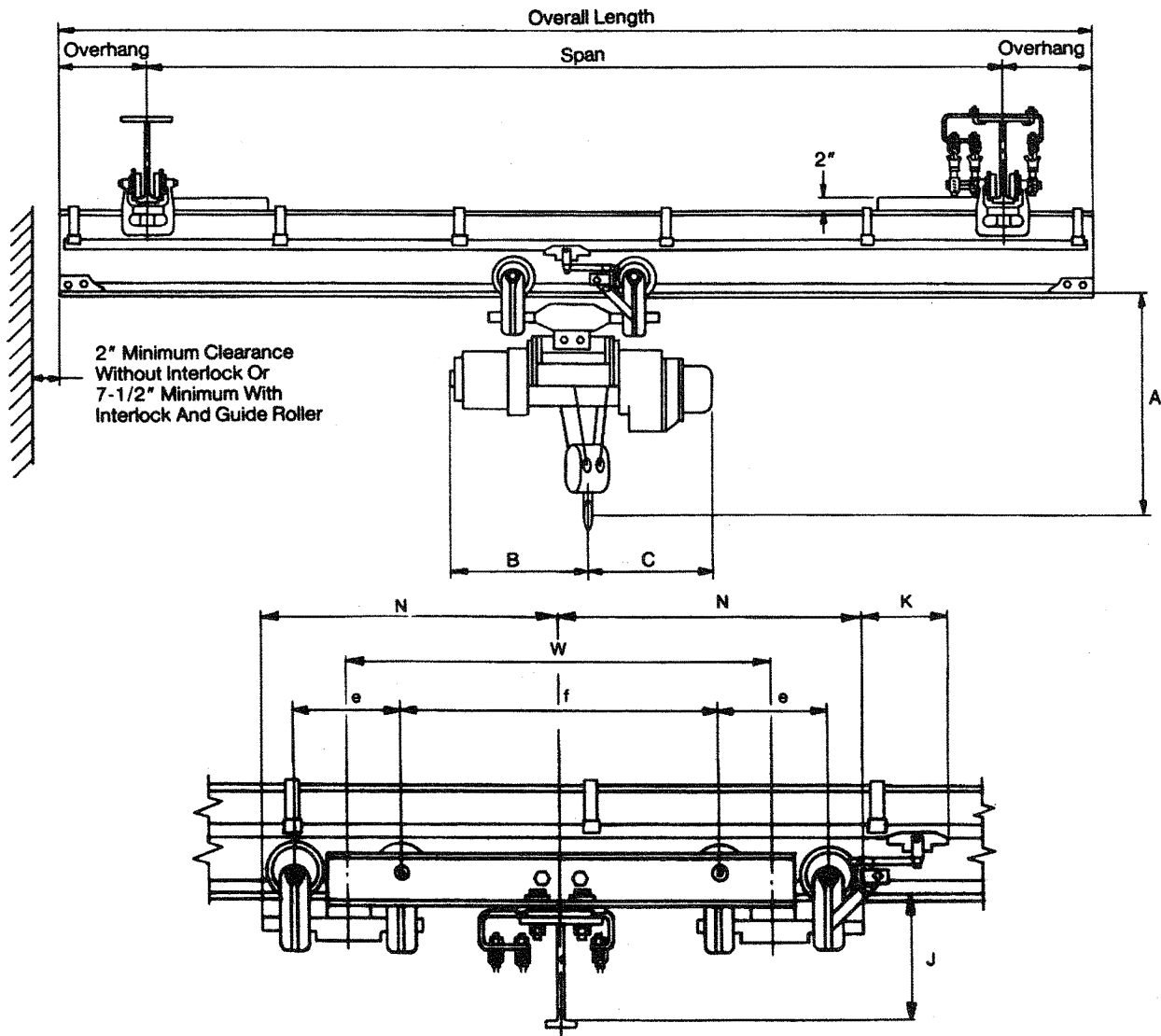

STANDARD SINGLE GIRDER CRANES

HAND PROPELLED CRANES WITH 8-WHEEL END TRUCKS

HAND PROPELLED CRANES WITH 8-WHEEL END TRUCKS												
Rated Load (Tons)	Design Load (Lbs.)	Crane Code Number	Net Weight (Lbs.)	Span (Ft.)	Overall Length (Ft.)	Minimum Runway Size	e	f	J	K	N	W
3	8030	HW16S212X14	1245	12	14	34011	1'-0	3'-8	10	9-1/2	3'-1-1/2	4'-8
		HW21S212X16	1339	14	16	34011	1'-0	3'-8	11-1/2	9-1/2	3'-1-1/2	4'-8
		HW21S212X18	1392	16	18	34011	1'-0	3'-8	11-1/2	9-1/2	3'-1-1/2	4'-8
		HW26S212X20	1528	18	20	34011	1'-0	3'-8	1'-1	9-1/2	3'-1-1/2	4'-8
		HW26S212X22	1624	20	22	34011	1'-0	3'-8	1'-1	9-1/2	3'-1-1/2	4'-8
		HW31S212X24	1759	22	24	34011	1'-0	3'-8	1'-2-1/2	9-1/2	3'-1-1/2	4'-8
		HW31S212X26	1822	24	36	34011	1'-0	3'-8	1'-2-1/2	9-1/2	3'-1-1/2	4'-8
		HW41S212X28	2147	36	28	34011	1'-0	3'-8	1'-3-1/4	9-1/2	3'-1-1/2	4'-8
		HW41S212X30	2233	28	30	34011	1'-0	3'-8	1'-3-1/4	9-1/2	3'-1-1/2	4'-8
		HW46S212X32	2448	30	32	34011	1'-0	3'-8	1'-5-1/4	9-1/2	3'-1-1/2	4'-8
		HW46S212X34	2542	32	34	34011	1'-0	3'-8	1'-5-1/4	9-1/2	3'-1-1/2	4'-8
		HW51S212X36	2909	34	36	34011	1'-0	3'-8	1'-7-1/4	9-1/2	3'-1-1/2	4'-8
		HW51S212X38	3016	36	38	34011	1'-0	3'-8	1'-7-1/4	9-1/2	3'-1-1/2	4'-8
		HW56S212X40	3312	38	40	34011	1'-0	3'-8	1'-9-1/4	9-1/2	3'-1-1/2	4'-8
HW56S212X42	3431	40	42	34011	1'-0	3'-8	1'-9-1/4	9-1/2	3'-1-1/2	4'-8		

STANDARD SINGLE GIRDER CRANES

CLEARANCE DRAWING FOR MOTOR DRIVEN CRANES WITH 4-WHEEL END TRUCKS

The drawing illustrates the clearance of a motor driven crane with 4-wheel end trucks and 7 conductor Insul-8-Bar electrification. Dimensions f, J and N are shown on the facing page. To determine dimensions A, B, And H, refer to

the appropriate clearance drawing in the Carrier Section for the hoist and carrier selected for the crane. See Page CR-10 for minimum, maximum and standard bridge girder overhangs.

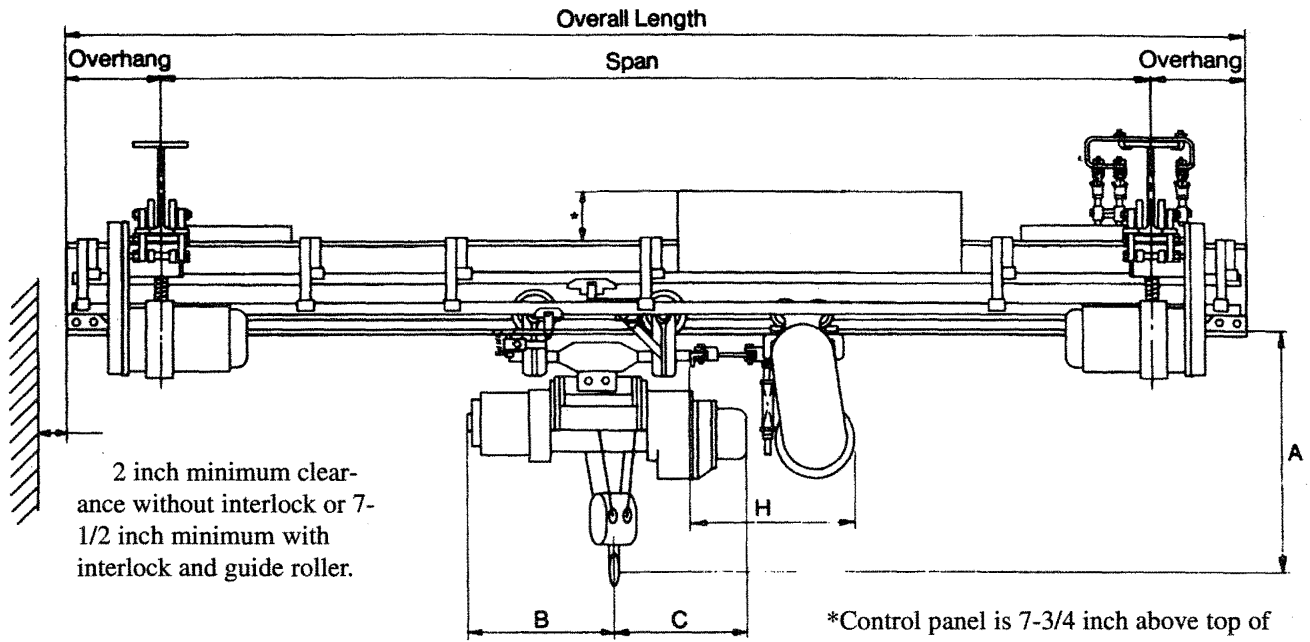

*Control panel is 7-3/4 inch above top of Nos. 34021 through 34056 girders. Panel is below top of girder for No. 34061 and larger girders.

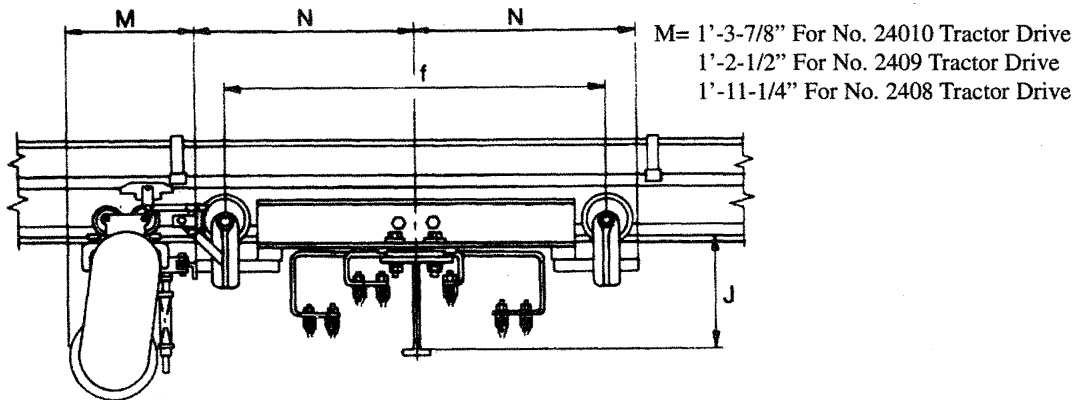

STANDARD SINGLE GIRDER CRANES

MOTOR DRIVEN CRANES WITH 4-WHEEL END TRUCKS

MOTOR DRIVEN CRANES WITH 4-WHEEL END TRUCKS									
Rated Load (Tons)	Design Load (Lbs.)	Crane Code Number	Net Weight (Lbs.)	Span (Ft.)	Overall Length (Ft.)	Minimum Runway Size	f	J	N
1	3180	MW21S204X22	1523	20	22	34011	4'-0	11-1/2	2'-3-1/8
		MW21S204X24	1588	22	24	34011	4'-0	11-1/2	2'-3-1/8
		MW21S204X26	1654	24	26	34011	4'-0	11-1/2	2'-3-1/8
		MW26S204X28	1833	26	28	34011	4'-0	1'-0	2'-3-1/8
		MW26S204X30	1906	28	30	34011	4'-0	1'-0	2'-3-1/8
		MW26S204X32	1980	30	32	34011	4'-0	1'-0	2'-3-1/8
		MW31S204X34	2155	32	34	34011	4'-0	1'-2-1/2	2'-3-1/8
		MW31S204X36	2234	34	36	34011	4'-0	1'-2-1/2	2'-3-1/8
		MW41S206X38	2683	36	38	34011	4'-0	1'-3-1/4	2'-3-1/8
		MW41S206X40	2772	38	40	34011	4'-0	1'-3-1/4	2'-3-1/8
		MW46S206X42	3046	40	42	34011	4'-0	1'-5-1/4	2'-3-1/8
		MW46S207X44	3236	42	44	34011	6'-0	1'-5-1/4	3'-3-1/8
		MW51S207X46	3686	44	46	34011	6'-0	1'-7-1/4	3'-3-1/8
		MW51S207X48	3807	46	48	34011	6'-0	1'-7-1/4	3'-3-1/8
		MW56S207X50	4161	48	50	34011	6'-0	1'-9-1/4	3'-3-1/8
		MW56S207X52	4286	50	52	34011	6'-0	1'-9-1/4	3'-3-1/8
		MW56S207X54	4415	52	54	34011	6'-0	1'-9-1/4	3'-3-1/8
		MW56S207X56	4545	54	56	34011	6'-0	1'-9-1/4	3'-3-1/8
		MW61S207X58	5046	56	58	34011	6'-0	1'-11-3/4	3'-3-1/8
		MW61S207X60	5187	58	60	34011	6'-0	1'-11-3/4	3'-3-1/8
		MW61S207X62	5364	60	62	34011	6'-0	1'-11-3/4	3'-3-1/8
		MW66S215X64	5471	62	64	34037	7'-0	2'-2-7/8	3'-10-1/4
		MW66S215X66	6625	64	66	34037	7'-0	2'-2-7/8	3'-10-1/4
MW66S215X68	6780	66	68	34037	7'-0	2'-2-7/8	3'-10-1/4		
MW71S215X70	7991	68	70	34037	7'-0	2'-5-3/8	3'-10-1/4		
MW71S215X72	8177	70	72	34037	7'-0	2'-5-3/8	3'-10-1/4		
2	5650	MW26S206X22	1642	20	22	34011	4'-0	1'-0	2'-3-1/8
		MW26S206X24	1715	22	24	34011	4'-0	1'-0	2'-3-1/8
		MW26S206X26	1788	24	26	34011	4'-0	1'-0	2'-3-1/8
		MW31S208X28	1975	26	28	34011	4'-0	1'-2-1/2	2'-3-3/4
		MW31S208X30	2048	28	30	34011	4'-0	1'-2-1/2	2'-3-3/4
		MW41S208X32	2421	30	32	34011	4'-0	1'-3-1/4	2'-3-3/4
		MW41S208X34	2519	32	34	34011	4'-0	1'-3-1/4	2'-3-3/4
		MW41S208X36	2616	34	36	34011	4'-0	1'-3-1/4	2'-3-3/4
		MW46S208X38	2865	36	38	34011	4'-0	1'-5-1/4	2'-3-3/4
		MW46S208X40	2970	38	40	34011	4'-0	1'-5-1/4	2'-3-3/4
		MW51S208X42	3395	40	42	34011	4'-0	1'-7-1/4	2'-3-3/4
		MW51S209X44	3679	42	44	34011	6'-0	1'-7-1/4	3'-3-3/4
		MW56S209X46	4015	44	46	34011	6'-0	1'-9-1/4	3'-3-3/4
		MW56S209X48	4145	46	48	34011	6'-0	1'-9-1/4	3'-3-3/4
		MW61S209X50	4589	48	50	34011	6'-0	1'-11-3/4	3'-3-3/4
		MW61S209X52	4732	50	52	34011	6'-0	1'-11-3/4	3'-3-3/4

STANDARD SINGLE GIRDER CRANES

CLEARANCE DRAWING FOR MOTOR DRIVEN CRANES WITH 4-WHEEL END TRUCKS

The drawing illustrates the clearances of a motor driven crane with 4-wheel end trucks and 7 conductor Insul-8-Bar electrification. Dimensions f, J and N are shown on the facing page. To determine dimension A, B, C and H, refer to the

appropriate clearance drawing in the Carrier Section for the hoist and carrier selected for the crane. See Page CR-10 for minimum, maximum and standard bridge girder overhangs.

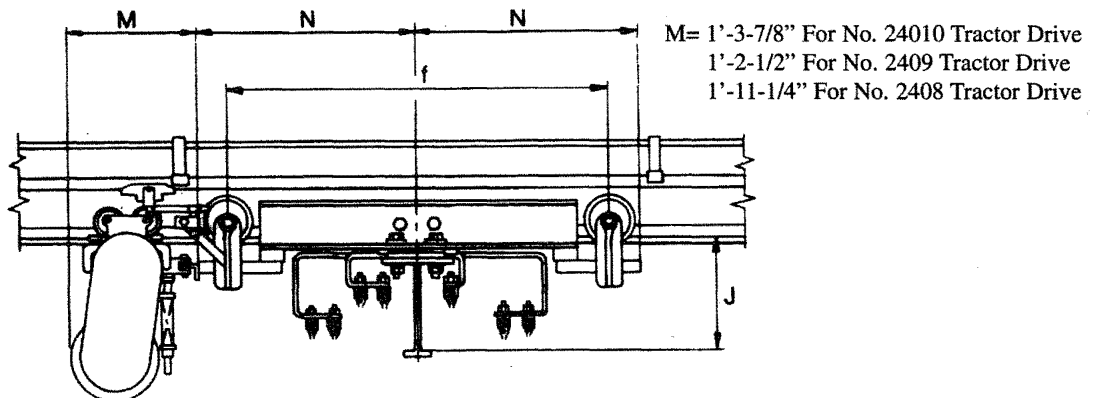
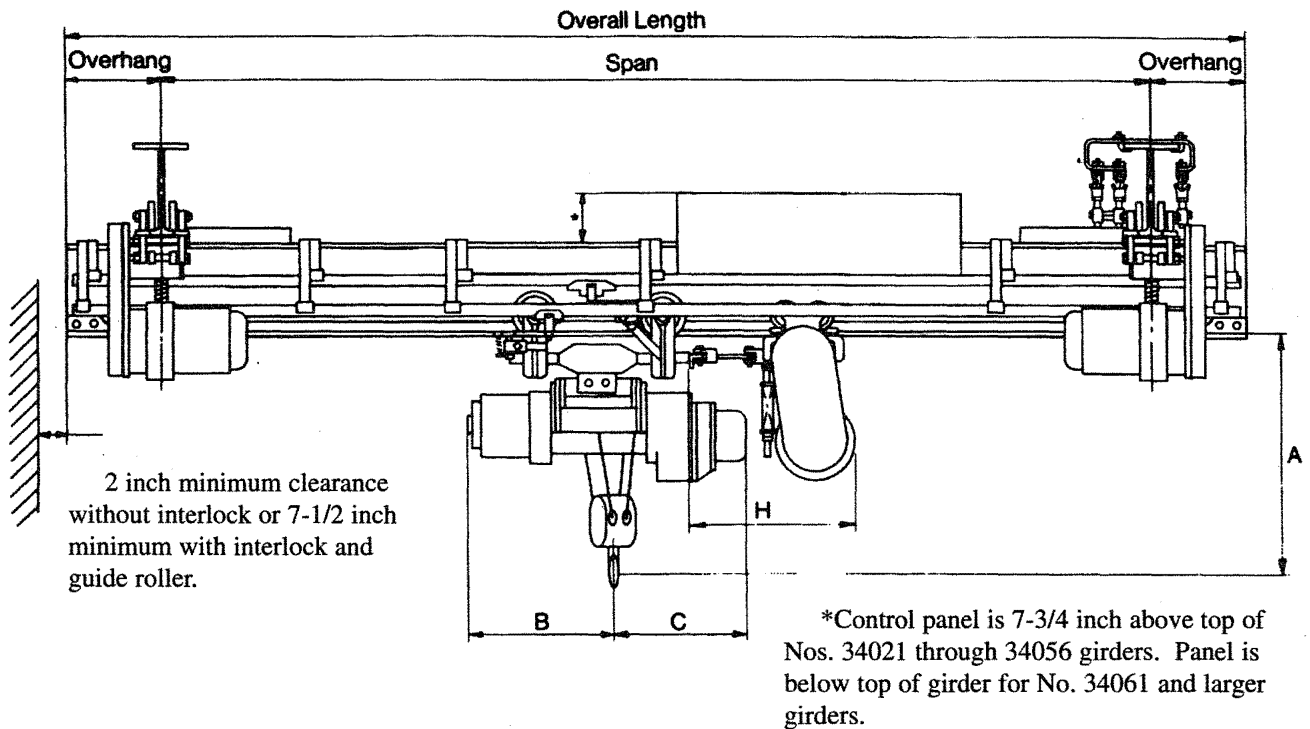

STANDARD SINGLE GIRDER CRANES

MOTOR DRIVEN CRANES WITH 4-WHEEL END TRUCKS

MOTOR DRIVEN CRANES WITH 4-WHEEL END TRUCKS									
Rated Load (Tons)	Design Load (Lbs.)	Crane Code Number	Net Weight (Lbs.)	Span (Ft.)	Overall Length (Ft.)	Minimum Runway Size	f	J	N
2	5650	MW66S209X54	5214	52	54	34011	6'-0	2'-2-1/4	3'-3-3/4
		MW66S209X56	5369	54	56	34011	6'-0	2'-2-1/4	3'-3-3/4
		MW66S209X58	5524	56	58	34011	6'-0	2'-2-1/4	3'-3-3/4
		MW71S215X60	7033	58	60	34037	7'-0	2'-5-3/8	3'-10-1/4
		MW71S215X62	7652	60	62	34037	7'-0	2'-5-3/8	3'-10-1/4
		MW71S215X64	7437	62	64	34037	7'-0	2'-5-3/8	3'-10-1/4
		MW76S215X66	8229	64	66	34037	7'-0	2'-7-7/8	3'-10-1/4
		MW76S215X68	8432	66	68	34037	7'-0	2'-7-7/8	3'-10-1/4
		MW76S215X70	8628	68	70	34037	7'-0	2'-7-7/8	3'-10-1/4
MW77S215X72	10026	70	72	34037	7'-0	2'-9-7/8	3'-10-1/4		
3	8290	MW37S214X22	2089	20	22	34037	4'-0	1'-2-3/8	2'-4-1/4
		MW37S214X24	2177	22	24	34037	4'-0	1'-2-3/8	2'-4-1/4
		MW37S214X26	2260	24	26	34037	4'-0	1'-2-3/8	2'-4-1/4
		MW41S214X28	2464	26	28	34037	4'-0	1'-3-7/8	2'-4-1/4
		MW41S214X30	2581	28	30	34037	4'-0	1'-3-7/8	2'-4-1/4
		MW46S214X32	2807	30	32	34037	4'-0	1'-5-7/8	2'-4-1/4
		MW46S214X34	2912	32	34	34037	4'-0	1'-5-7/8	2'-4-1/4
		MW51S214X36	3290	34	36	34037	4'-0	1'-7-7/8	2'-4-1/4
		MW51S214X38	3408	36	38	34037	4'-0	1'-7-7/8	2'-4-1/4
		MW56S214X40	3715	38	40	34037	4'-0	1'-9-7/8	2'-4-1/4
		MW61S214X42	4114	40	42	34037	4'-0	2'-0-3/8	2'-4-1/4
		MW61S215X44	4618	42	44	34037	7'-0	2'-0-3/8	3'-10-1/4
		MW61S215X46	4760	44	46	34037	7'-0	2'-0-3/8	3'-10-1/4
		MW66S215X48	5204	46	48	34037	7'-0	2'-2-7/8	3'-10-1/4
		MW66S215X50	5359	48	50	34037	7'-0	2'-2-7/8	3'-10-1/4
		MW71S215X52	6299	50	52	34037	7'-0	2'-5-3/8	3'-10-1/4
		MW71S215X54	6484	52	54	34037	7'-0	2'-5-3/8	3'-10-1/4
		MW71S215X56	6664	54	56	34037	7'-0	2'-5-3/8	3'-10-1/4
		MW76S215X58	7382	56	58	34037	7'-0	2'-7-7/8	3'-10-1/4
		MW76S215X60	7585	58	60	34037	7'-0	2'-7-7/8	3'-10-1/4
		MW76S215X62	7823	60	62	34037	7'-0	2'-7-7/8	3'-10-1/4
		MW76S215X64	8019	62	64	34037	7'-0	2'-7-7/8	3'-10-1/4
		MW77S215X66	9318	64	66	34037	7'-0	2'-9-7/8	3'-10-1/4
		MW77S215X68	9561	66	68	34037	7'-0	2'-9-7/8	3'-10-1/4
MW77S215X70	9797	68	70	34037	7'-0	2'-9-7/8	3'-10-1/4		
MW77S215X72	10034	70	72	34037	7'-0	2'-9-7/8	3'-10-1/4		

STANDARD SINGLE GIRDER CRANES

CLEARANCE DRAWING FOR MOTOR DRIVEN CRANES WITH 8-WHEEL END TRUCKS

The drawing illustrates the clearances of a motor driven crane with 8-wheel end trucks and 7 conductor Insul-8-Bar electrification. Dimensions e, f, J, N and W are shown on the facing page. To determine dimension A, B, C and H, refer to

the appropriate clearance drawing in the Carrier Section for the hoist and carrier selected for the crane. See Page CR-10 for minimum, maximum and standard bridge girder overhangs.

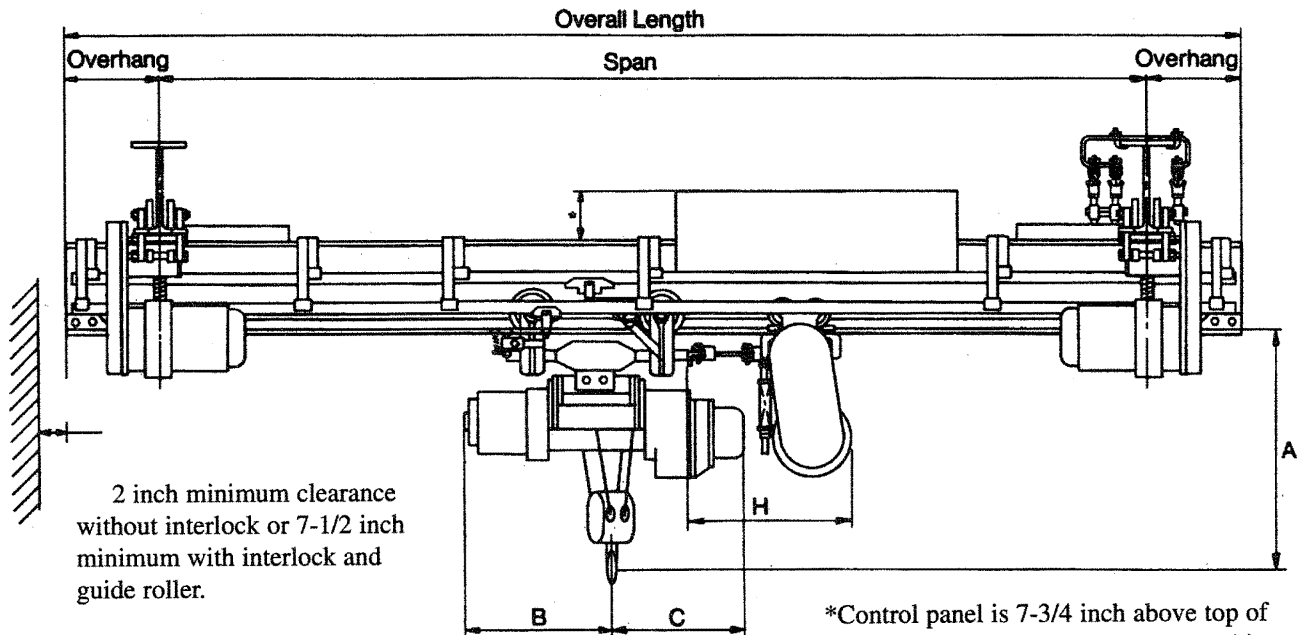

*Control panel is 7-3/4 inch above top of Nos. 34021 through 34056 girders. Panel is below top of girder for No. 34061 and larger girders.

- M= 1'-3-7/8" For No. 24010 Tractor Drive
- 1'-2-1/2" For No. 2409 Tractor Drive
- 1'-11-1/4" For No. 2408 Tractor Drive

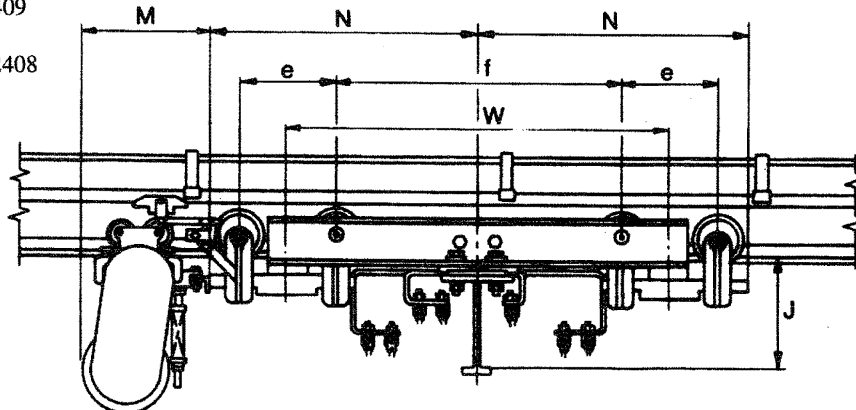

STANDARD SINGLE GIRDER CRANES

MOTOR DRIVEN CRANES WITH 8-WHEEL END TRUCKS

MOTOR DRIVEN CRANES WITH 8-WHEEL END TRUCKS											
Rated Load (Tons)	Design Load (Lbs.)	Crane Code Number	Net Weight (Lbs.)	Span (Ft.)	Overall Length (Ft.)	Minimum Runway Size	e	f	J	N	W
1	3180	MW66S213X64	6551	62	64	34031	1'-0	7'-0	2'-2-1/4	4'-9-1/2	8'-0
		MW66S213X66	6705	64	66	34031	1'-0	7'-0	2'-2-1/4	4'-9-1/2	8'-0
		MW66S213X68	6860	66	68	34031	1'-0	7'-0	2'-2-1/4	4'-9-1/2	8'-0
		MW71S213X70	8071	68	70	34031	1'-0	7'-0	2'-4-3/4	4'-9-1/2	8'-0
		MW71S213X72	8257	70	72	34031	1'-0	7'-0	2'-4-3/4	4'-9-1/2	8'-0
		MW76S213X74	9114	72	74	34031	1'-0	7'-0	2'-7-1/4	4'-9-1/2	8'-0
		MW76S213X76	9318	74	76	34031	1'-0	7'-0	2'-7-1/4	4'-9-1/2	8'-0
		MW76S213X78	9521	76	78	34031	1'-0	7'-0	2'-7-1/4	4'-9-1/2	8'-0
		MW76S213X80	9739	78	80	34031	1'-0	7'-0	2'-7-1/4	4'-9-1/2	8'-0
		MW77S213X82	11304	80	82	34031	1'-0	7'-0	2'-9-1/4	4'-9-1/2	8'-0
		MW78S221X84	14019	82	84	34041	1'-3	8'-9	3'-1-7/8	5'-11-3/4	10'-0
		MW78S221X86	14282	84	86	34041	1'-3	8'-9	3'-1-7/8	5'-11-3/4	10'-0
		MW78S221X88	14537	86	88	34041	1'-3	8'-9	3'-1-7/8	5'-11-3/4	10'-0
		MW78S221X90	14899	88	90	34041	1'-3	8'-9	3'-1-7/8	5'-11-3/4	10'-0
		MW78S221X92	15063	90	92	34041	1'-3	8'-9	3'-1-7/8	5'-11-3/4	10'-0
		MW79S221X94	16596	92	94	34041	1'-3	8'-9	3'-5-7/8	5'-11-3/4	10'-0
		MW79S221X96	16886	94	96	34041	1'-3	8'-9	3'-5-7/8	5'-11-3/4	10'-0
MW79S221X98	17177	96	98	34041	1'-3	8'-9	3'-5-7/8	5'-11-3/4	10'-0		
MW79S221X100	17477	98	100	34041	1'-3	8'-9	3'-5-7/8	5'-11-3/4	10'-0		
MW79S221X102	17768	100	102	34041	1'-3	8'-9	3'-5-7/8	5'-11-3/4	10'-0		
2	5650	MW71S213X64	7517	62	64	34031	1'-0	7'-0	2'-4-3/4	4'-9-1/2	8'-0
		MW76S213X66	8309	64	66	34031	1'-0	7'-0	2'-7-1/4	4'-9-1/2	8'-0
		MW76S213X68	8512	66	68	34031	1'-0	7'-0	2'-7-1/4	4'-9-1/2	8'-0
		MW76S213X70	8708	68	70	34031	1'-0	7'-0	2'-7-1/4	4'-9-1/2	8'-0
		MW77S213X72	10106	70	72	34031	1'-0	7'-0	2'-9-1/4	4'-9-1/2	8'-0
		MW77S213X74	10358	72	74	34031	1'-0	7'-0	2'-9-1/4	4'-9-1/2	8'-0
		MW77S213X76	10594	74	76	34031	1'-0	7'-0	2'-9-1/4	4'-9-1/2	8'-0
		MW77S213X78	10831	76	78	34031	1'-0	7'-0	2'-9-1/4	4'-9-1/2	8'-0
		MW77S213X80	11067	78	80	34031	1'-0	7'-0	2'-9-1/4	4'-9-1/2	8'-0
		MW77S213X82	11303	80	82	34031	1'-0	7'-0	2'-9-1/4	4'-9-1/2	8'-0
		MW78S221X84	14019	82	84	34041	1'-3	8'-9	3'-1-7/8	5'-11-3/4	10'-0
		MW78S221X86	14282	84	86	34041	1'-3	8'-9	3'-1-7/8	5'-11-3/4	10'-0
		MW78S221X88	14537	86	88	34041	1'-3	8'-9	3'-1-7/8	5'-11-3/4	10'-0
		MW78S221X90	14800	88	90	34041	1'-3	8'-9	3'-1-7/8	5'-11-3/4	10'-0
		MW78S221X92	15063	90	92	34041	1'-3	8'-9	3'-1-7/8	5'-11-3/4	10'-0
		MW79S221X94	16596	92	94	34041	1'-3	8'-9	3'-5-7/8	5'-11-3/4	10'-0
		MW79S221X96	16886	94	96	34041	1'-3	8'-9	3'-5-7/8	5'-11-3/4	10'-0
MW79S221X98	17177	96	98	34041	1'-3	8'-9	3'-5-7/8	5'-11-3/4	10'-0		

STANDARD SINGLE GIRDER CRANES

CLEARANCE DRAWING FOR MOTOR DRIVEN CRANES WITH 8-WHEEL END TRUCKS

The drawing illustrates the clearances of a motor driven crane with 8-wheel end trucks and 7 conductor Insul-8-Bar electrification. Dimensions e, f, J, N and W are shown on the facing page. To determine dimension A, B, C and H, refer to

the appropriate clearance drawing in the Carrier Section for the hoist and carrier selected for the crane. See Page CR-10 for minimum, maximum and standard bridge girder overhangs.

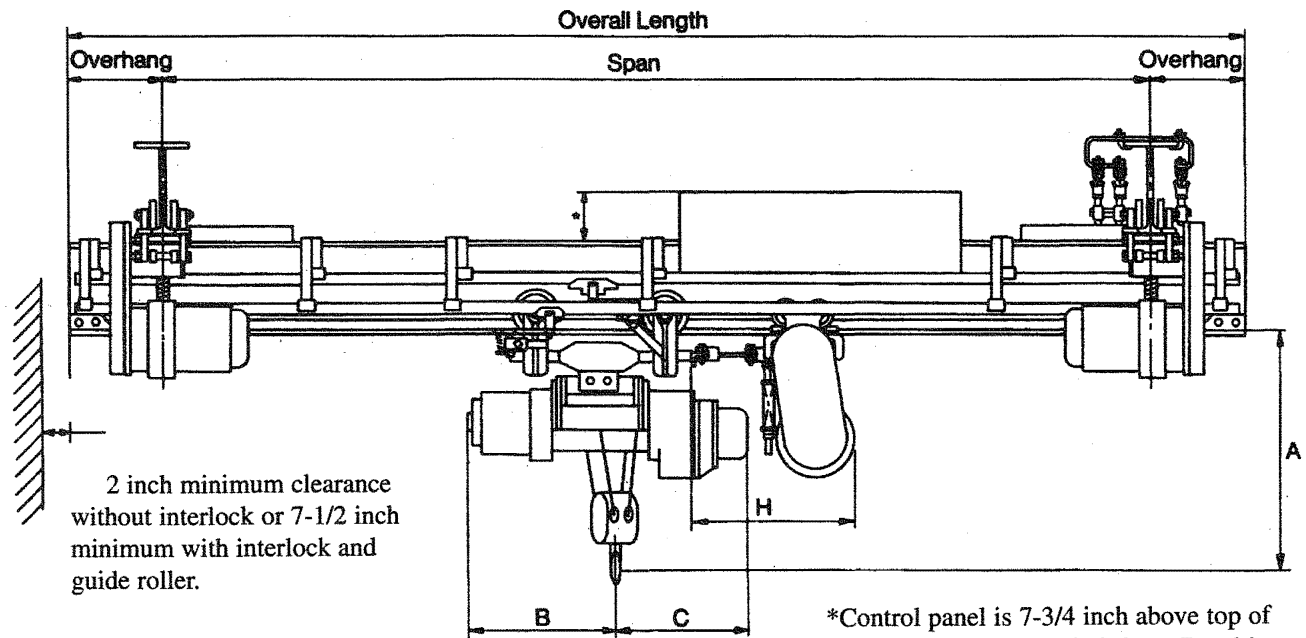

*Control panel is 7-3/4 inch above top of Nos. 34021 through 34056 girders. Panel is below top of girder for No. 34061 and larger girders.

- M= 1'-3-7/8" For No. 24010 Tractor Drive
- 1'-2-1/2" For No. 2409 Tractor Drive
- 1'-11-1/4" For No. 2408 Tractor Drive

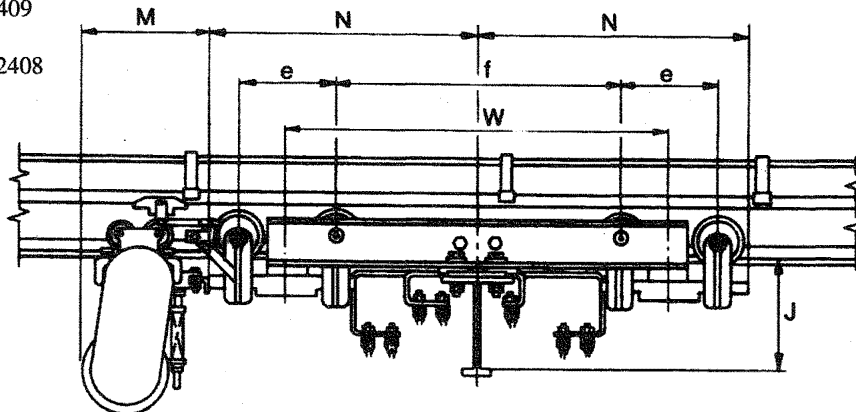

STANDARD SINGLE GIRDER CRANES

MOTOR DRIVEN CRANES WITH 8-WHEEL END TRUCKS

MOTOR DRIVEN CRANES WITH 8-WHEEL END TRUCKS											
Rated Load (Tons)	Design Load (Lbs.)	Crane Code Number	Net Weight (Lbs.)	Span (Ft.)	Overall Length (Ft.)	Minimum Runway Size	e	f	J	N	W
3	8290	MW37S212X22	2346	20	22	34011	1'-0	3'-8	1'-1-3/4	3'-1-1/2	4'-8
		MW37S212X24	2414	22	24	34011	1'-0	3'-8	1'-1-3/4	3'-1-1/2	4'-8
		MW37S212X26	2517	24	26	34011	1'-0	3'-8	1'-1-3/4	3'-1-1/2	4'-8
		MW41S212X28	2741	26	28	34011	1'-0	3'-8	1'-3-1/4	3'-1-1/2	4'-8
		MW41S212X30	2838	28	30	34011	1'-0	3'-8	1'-3-1/4	3'-1-1/2	4'-8
		MW46S212X32	3064	30	32	34011	1'-0	3'-8	1'-5-1/4	3'-1-1/2	4'-8
		MW46S212X34	3169	32	34	34011	1'-0	3'-8	1'-5-1/4	3'-1-1/2	4'-8
		MW51S212X36	3547	34	36	34011	1'-0	3'-8	1'-7-1/4	3'-1-1/2	4'-8
		MW51S212X38	3665	36	38	34011	1'-0	3'-8	1'-7-1/4	3'-1-1/2	4'-8
		MW56S212X40	3972	38	40	34011	1'-0	3'-8	1'-9-1/4	3'-1-1/2	4'-8
		MW61S212X42	4371	40	42	34011	1'-0	3'-8	1'-11-3/4	3'-1-1/2	4'-8
		MW61S212X44	4509	42	44	34011	1'-0	3'-8	1'-11-3/4	3'-1-1/2	4'-8
		MW61S212X46	4651	44	46	34011	1'-0	3'-8	1'-11-3/4	3'-1-1/2	4'-8
		MW66S212X48	5095	46	48	34011	1'-0	3'-8	2'-2-1/4	3'-1-1/2	4'-8
		MW66S212X50	5438	48	50	34011	1'-0	3'-8	2'-2-1/4	3'-1-1/2	4'-8
		MW71S213X52	6378	50	52	34031	1'-0	7'-0	2'-4-3/4	4'-9-1/2	8'-0
		MW71S213X54	6563	51	54	34031	1'-0	7'-0	2'-4-3/4	4'-9-1/2	8'-0
		MW71S213X56	6743	54	56	34031	1'-0	7'-0	2'-4-3/4	4'-9-1/2	8'-0
		MW76S213X58	7461	56	58	34031	1'-0	7'-0	2'-7-1/4	4'-9-1/2	8'-0
		MW76S213X60	7664	58	60	34031	1'-0	7'-0	2'-7-1/4	4'-9-1/2	8'-0
		MW76S213X62	7903	60	62	34031	1'-0	7'-0	2'-7-1/4	4'-9-1/2	8'-0
		MW76S213X64	8099	62	64	34031	1'-0	7'-0	2'-7-1/4	4'-9-1/2	8'-0
		MW77S213X66	9398	64	66	34031	1'-0	7'-0	2'-9-1/4	4'-9-1/2	8'-0
		MW77S219X68	10002	66	68	34031	1'-0	7'-0	2'-9-1/4	4'-9-1/2	8'-0
		MW77S219X70	10238	68	70	34031	1'-0	7'-0	2'-9-1/4	4'-9-1/2	8'-0
		MW77S219X72	10475	70	72	34031	1'-0	7'-0	2'-9-1/4	4'-9-1/2	8'-0
		MW77S219X74	10719	72	74	34031	1'-0	7'-0	2'-9-1/4	4'-9-1/2	8'-0
		MW77S219X76	10955	74	76	34031	1'-0	7'-0	2'-9-1/4	4'-9-1/2	8'-0
		MW77S219X78	11192	76	78	34031	1'-0	7'-0	2'-9-1/4	4'-9-1/2	8'-0
		MW78S219X80	12508	78	90	34031	1'-0	7'-0	3'-1-1/4	4'-9-1/2	8'-0
MW78S219X82	12772	80	82	34031	1'-0	7'-0	3'-1-1/4	4'-9-1/2	8'-0		
MW78S221X84	14010	82	84	34041	1'-3	8'-9	3'-1-7/8	5'-11-3/4	10'-0		
MW79S221X86	15434	84	86	34041	1'-3	8'-9	3'-5-7/8	5'-11-3/4	10'-0		
MW79S221X88	15725	86	88	34041	1'-3	8'-9	3'-5-7/8	5'-11-3/4	10'-0		
MW79S221X90	16015	88	90	34041	1'-3	8'-9	3'-5-7/8	5'-11-3/4	10'-0		

STANDARD SINGLE GIRDER CRANES

CLEARANCE DRAWING FOR MOTOR DRIVEN CRANES WITH 8-WHEEL END TRUCKS

The drawing illustrates the clearances of a motor driven crane with 8-wheel end trucks and 7 conductor Insul-8-Bar electrification. Dimensions e, f, J, N and W are shown on the facing page. To determine dimension A, B, C and H, refer to

the appropriate clearance drawing in the Carrier Section for the hoist and carrier selected for the crane. See Page CR-10 for minimum, maximum and standard bridge girder overhangs.

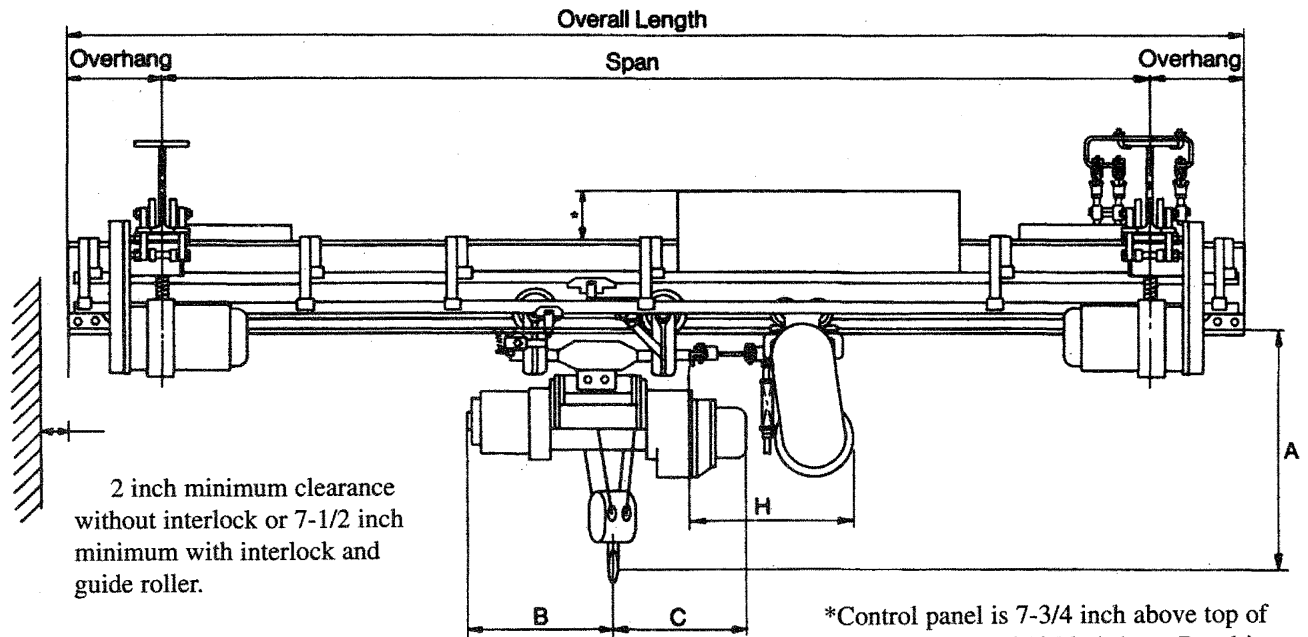

*Control panel is 7-3/4 inch above top of Nos. 34021 through 34056 girders. Panel is below top of girder for No. 34061 and larger girders.

- M= 1'-3-7/8" For No. 24010 Tractor Drive
- 1'-2-1/2" For No. 2409 Tractor Drive
- 1'-11-1/4" For No. 2408 Tractor Drive

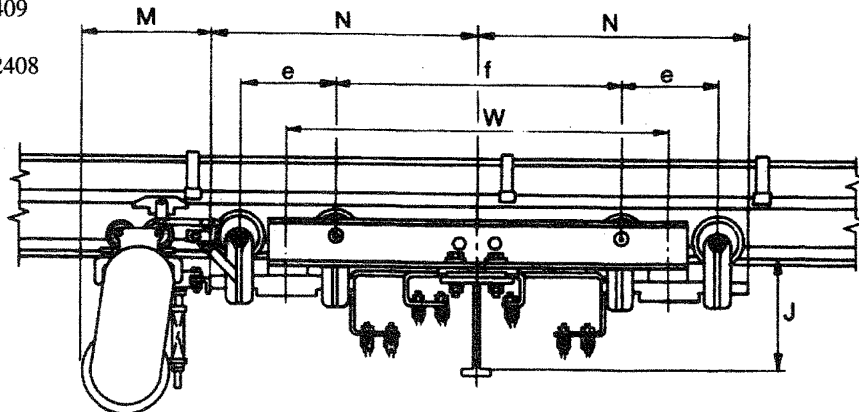

STANDARD SINGLE GIRDER CRANES

MOTOR DRIVEN CRANES WITH 8-WHEEL END TRUCKS

MOTOR DRIVEN CRANES WITH 8-WHEEL END TRUCKS											
Rated Load (Tons)	Design Load (Lbs.)	Crane Code Number	Net Weight (Lbs.)	Span (Ft.)	Overall Length (Ft.)	Minimum Runway Size	e	f	J	N	W
5	13360	MW41S218X22	2479	20	22	34011	1'-0	3'-8	1'-3-1/4	3'-1-1/2	4'-8
		MW41S218X24	2521	22	24	34011	1'-0	3'-8	1'-3-1/4	3'-1-1/2	4'-8
		MW46S218X26	2777	24	26	34011	1'-0	3'-8	1'-5-1/4	3'-1-1/2	4'-8
		MW46S218X28	2882	26	28	34011	1'-0	3'-8	1'-5-1/4	3'-1-1/2	4'-8
		MW51S218X30	3212	28	30	34011	1'-0	3'-8	1'-7-1/4	3'-1-1/2	4'-8
		MW56S218X32	3483	30	32	34011	1'-0	3'-8	1'-9-1/4	3'-1-1/2	4'-8
		MW56S218X34	3613	32	34	34011	1'-0	3'-8	1'-9-1/4	3'-1-1/2	4'-8
		MW61S218X36	3969	34	36	34011	1'-0	3'-8	1'-11-3/4	3'-1-1/2	4'-8
		MW61S218X38	4111	36	38	34011	1'-0	3'-8	1'-11-3/4	3'-1-1/2	4'-8
		MW66S218X40	4326	38	40	34011	1'-0	3'-8	2'-2-1/4	3'-1-1/2	4'-8
		MW66S218X42	4660	40	42	34011	1'-0	3'-8	2'-2-1/4	3'-1-1/2	4'-8
		MW71S218X44	5479	42	44	34011	1'-0	3'-8	2'-4-3/4	3'-1-1/2	4'-8
		MW71S218X46	5665	44	46	34011	1'-0	3'-8	2'-4-3/4	3'-1-1/2	4'-8
		MW71S218X48	5845	46	48	34011	1'-0	3'-8	2'-4-3/4	3'-1-1/2	4'-8
		MW76S219X50	7009	48	50	34031	1'-0	7'-0	2'-7-1/4	4'-9-1/2	8'-0
		MW76S219X52	7213	50	52	34031	1'-0	7'-0	2'-7-1/4	4'-9-1/2	8'-0
		MW76S219X54	7416	52	54	34031	1'-0	7'-0	2'-7-1/4	4'-9-1/2	8'-0
		MW77S220X56	8029	54	56	34037	1'-3	4'-6	2'-9-7/8	3'-10-1/4	5'-9
		MW77S220X58	8264	56	58	34037	1'-3	4'-6	2'-9-7/8	3'-10-1/4	5'-9
		MW77S221X60	9999	58	60	34041	1'-3	8'-9	2'-9-7/8	5'-11-3/4	10'-0
		MW77S221X62	10276	60	62	34041	1'-3	8'-9	2'-9-7/8	5'-11-3/4	10'-0
		MW77S221X64	10512	62	64	34041	1'-3	8'-9	2'-9-7/8	5'-11-3/4	10'-0
		MW77S221X66	10749	64	66	34041	1'-3	8'-9	2'-9-7/8	5'-11-3/4	10'-0
		MW78S221X68	11910	66	68	34041	1'-3	8'-9	3'-1-7/8	5'-11-3/4	10'-0
		MW78S221X70	12173	68	70	34041	1'-3	8'-9	3'-1-7/8	5'-11-3/4	10'-0
		MW78S221X72	13422	70	72	34041	1'-3	8'-9	3'-1-7/8	5'-11-3/4	10'-0
		MW79S221X74	13684	72	74	34041	1'-3	8'-9	3'-5-7/8	5'-11-3/4	10'-0
		MW79S221X76	13982	74	76	34041	1'-3	8'-9	3'-5-7/8	5'-11-3/4	10'-0
		MW79S221X78	14273	76	78	34041	1'-3	8'-9	3'-5-7/8	5'-11-3/4	10'-0

STANDARD SINGLE GIRDER CRANES

CLEARANCE DRAWING FOR MOTOR DRIVEN CRANES WITH 8-WHEEL END TRUCKS

The drawing illustrates the clearances of a motor driven crane with 8-wheel end trucks and 7 conductor Insul-8-Bar electrification. Dimensions e, f, J, N and W are shown on the facing page. To determine dimension A, B, C and H, refer to

the appropriate clearance drawing in the Carrier Section for the hoist and carrier selected for the crane. See Page CR-10 for minimum, maximum and standard bridge girder overhangs.

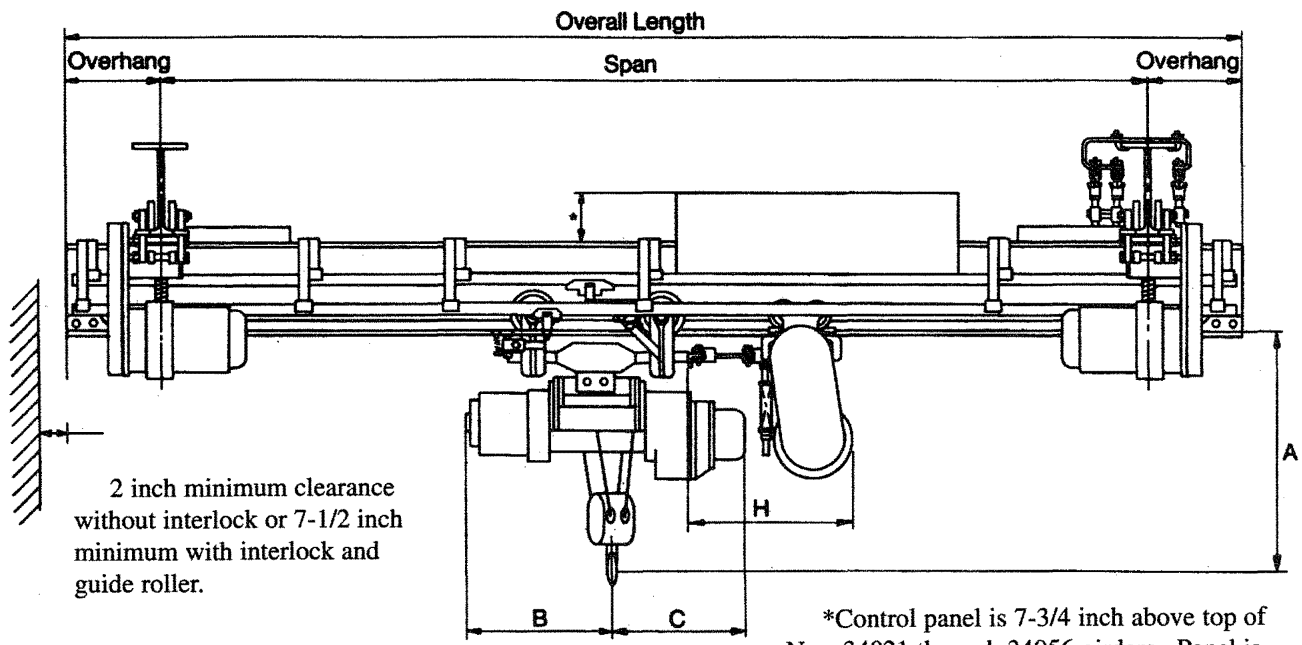

*Control panel is 7-3/4 inch above top of Nos. 34021 through 34056 girders. Panel is below top of girder for No. 34061 and larger girders.

- M= 1'-3-7/8" For No. 24010 Tractor Drive
- 1'-2-1/2" For No. 2409 Tractor Drive
- 1'-11-1/4" For No. 2408 Tractor Drive

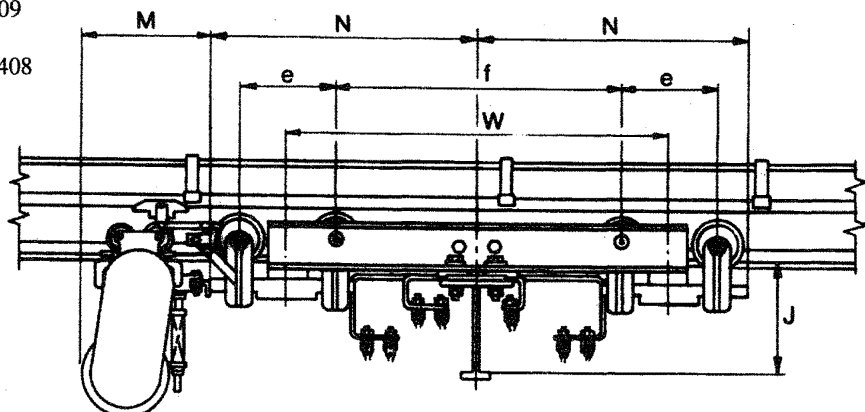

STANDARD SINGLE GIRDER CRANES

MOTOR DRIVEN CRANES WITH 8-WHEEL END TRUCKS

MOTOR DRIVEN CRANES WITH 8-WHEEL END TRUCKS											
Rated Load (Tons)	Design Load (Lbs.)	Crane Code Number	Net Weight (Lbs.)	Span (Ft.)	Overall Length (Ft.)	Minimum Runway Size	e	f	J	N	W
7-1/2	19480	MW46S220X22	3148	20	22	34037	1'-3	4'-6	1'-5-7/8	3'-10-1/4	5'-9
		MW51S220X24	3436	22	24	34037	1'-3	4'-6	1'-7-7/8	3'-10-1/4	5'-9
		MW51S220X26	3553	24	26	34037	1'-3	4'-6	1'-7-7/8	3'-10-1/4	5'-9
		MW56S220X28	3805	26	28	34037	1'-3	4'-6	1'-9-7/8	3'-10-1/4	5'-9
		MW61S220X30	4126	28	30	34037	1'-3	4'-6	2'-0-3/8	3'-10-1/4	5'-9
		MW61S220X32	4268	30	32	34037	1'-3	4'-6	2'-0-3/8	3'-10-1/4	5'-9
		MW66S220X34	4635	32	34	34037	1'-3	4'-6	2'-2-7/8	3'-10-1/4	5'-9
		MW66S220X36	4791	34	36	34037	1'-3	4'-6	2'-2-7/8	3'-10-1/4	5'-9
		MW71S220X38	5505	36	38	34037	1'-3	4'-6	2'-5-3/8	3'-10-1/4	5'-9
		MW71S220X40	5689	38	40	34037	1'-3	4'-6	2'-5-3/8	3'-10-1/4	5'-9
		MW76S220X42	6261	40	42	34037	1'-3	4'-6	2'-7-7/8	3'-10-1/4	5'-9
		MW76S220X44	6464	42	44	34037	1'-3	4'-6	2'-7-7/8	3'-10-1/4	5'-9
		MW76S220X46	6667	44	46	34037	1'-3	4'-6	2'-7-7/8	3'-10-1/4	5'-9
		MW77S220X48	7667	46	48	34037	1'-3	4'-6	2'-9-7/8	3'-10-1/4	5'-9
		MW77S220X50	7898	48	50	34037	1'-3	4'-6	2'-9-7/8	3'-10-1/4	5'-9
		MW77S220X52	8134	50	52	34037	1'-3	4'-6	2'-9-7/8	3'-10-1/4	5'-9
		MW77S220X54	8371	52	54	34037	1'-3	4'-6	2'-9-7/8	3'-10-1/4	5'-9
		MW77S220X56	8613	54	56	34037	1'-3	4'-6	2'-9-7/8	3'-10-1/4	5'-9
		MW77S220X58	8849	56	58	34037	1'-3	4'-6	2'-9-7/8	3'-10-1/4	5'-9
		MW78S221X60	10851	58	60	34041	1'-3	8'-9	3'-1-7/8	5'-11-3/4	5'-9
MW78S221X62	11106	60	62	34041	1'-3	8'-9	3'-1-7/8	5'-11-3/4	10'-0		
MW78S221X64	11369	62	64	34041	1'-3	8'-9	3'-1-7/8	5'-11-3/4	10'-0		
MW79S221X66	12524	64	66	34041	1'-3	8'-9	3'-5-7/8	5'-11-3/4	10'-0		
MW79S221X68	12821	66	68	34041	1'-3	8'-9	3'-5-7/8	5'-11-3/4	10'-0		
MW79S221X70	13104	68	70	34041	1'-3	8'-9	3'-5-7/8	5'-11-3/4	10'-0		
10	26270	MW56S220X22	3424	20	22	34037	1'-3	4'-6	1'-9-7/8	3'-10-1/4	5'-9
		MW56S220X24	3553	22	24	34037	1'-3	4'-6	1'-9-7/8	3'-10-1/4	5'-9
		MW61S220X26	3849	24	26	34037	1'-3	4'-6	2'-0-3/8	3'-10-1/4	5'-9
		MW61S220X28	3992	26	28	34037	1'-3	4'-6	2'-0-3/8	3'-10-1/4	5'-9
		MW66S220X30	4319	28	30	34037	1'-3	4'-6	2'-2-7/8	3'-10-1/4	5'-9
		MW71S220X32	4957	30	32	34037	1'-3	4'-6	2'-5-3/8	3'-10-1/4	5'-9
		MW71S220X34	5142	32	34	34037	1'-3	4'-6	2'-5-3/8	3'-10-1/4	5'-9
		MW71S220X36	5327	34	36	34037	1'-3	4'-6	2'-5-3/8	3'-10-1/4	5'-9
		MW76S222X38	6445	36	38	34037	1'-3	4'-6	2'-7-7/8	3'-10-1/4	5'-9
		MW76S222X40	6644	38	40	34037	1'-3	4'-6	2'-7-7/8	3'-10-1/4	5'-9
		MW77S222X42	7544	40	42	34037	1'-3	4'-6	2'-9-7/8	3'-10-1/4	5'-9
		MW77S222X44	7785	42	44	34037	1'-3	4'-6	2'-9-7/8	3'-10-1/4	5'-9
		MW77S222X46	8022	44	46	34037	1'-3	4'-6	2'-9-7/8	3'-10-1/4	5'-9
		MW77S222X48	8263	46	48	34037	1'-3	4'-6	2'-9-7/8	3'-10-1/4	5'-9
		MW77S222X50	8489	48	50	34037	1'-3	4'-6	2'-9-7/8	3'-10-1/4	5'-9
		MW78S222X52	9427	50	52	34037	1'-3	4'-6	3'-1-7/8	3'-10-1/4	5'-9
		MW78S222X54	9690	52	54	34037	1'-3	4'-6	3'-1-7/8	3'-10-1/4	5'-9
		MW78S222X56	9954	54	56	34037	1'-3	4'-6	3'-1-7/8	3'-10-1/4	5'-9
		MW79S222X58	11006	56	58	34037	1'-3	4'-6	3'-5-7/8	3'-10-1/4	5'-9
		MW79S223X60	12124	58	60	34041	1'-3	8'-0	3'-5-7/8	5'-7-1/4	9'-3
MW79S223X62	13242	60	62	34041	1'-3	8'-0	3'-5-7/8	5'-7-1/4	9'-3		