

The Wright-Way Tractor Drive is highly efficient for horizontal movement of a hoist, bridge crane or other equipment.

Through a speed reduction, the drive action of the motor is transmitted to a rubber tire wheel which is spring loaded to provide steady traction as it rolls against the underside of the track. The standard units can be ordered for operation on 2", 3.25" or 3.33" flange track and will negotiate a minimum 29" radius curve. Additionally, it will operate through track switches, crane latches, and turntables. This tractor drive can additionally be ordered from Acco Wright for operation on structural beams.

SPEEDS:

Standard speeds are 30, 40, 60 and 80 FPM. Single speed control with ACM is standard (in NEMA 12 enclosure). Two speed units are available. Variable speed can be accomplished by installing the tractor drive controls in the hoist/crane panel and wiring between the hoist/crane and tractor control enclosures.

MOTORS:

Standard motors provided are NEMA C face, TENV, Class F insulation, 30-minute duty and are available for standard commercial power supplies. The motor has a standard NEMA shaft extension. The motors are designed for intermittent reversing crane and trolley drive service. Standard motors are CSA approved.

BRAKE:

A direct acting, short stroke AC magnet actuated disc type motor brake is standard. This brake has a minimum torque rating of 150% of the full load motor torque. The brake provides accurate spotting and control of the load by quickly stopping the motor when power is interrupted.

GEARING:

The gear train is a combination of helical and spur gears with all contact surfaces hardened for wear resistance and designed to AGMA standards for maximum life. Gears operate in a sealed oil bath. All gears and pinion shafts are supported on both ends by antifriction ball bearings.

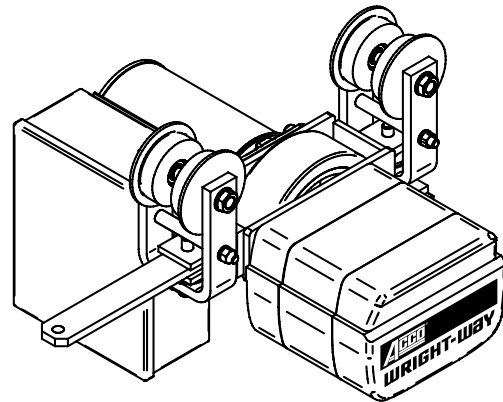

CONSTRUCTION:

The tractor drive frame is produced from rugged malleable iron. The tractor drive is spring loaded to absorb shock loads and to maintain constant pressure on the drive tire.

DRIVE WHEEL:

The 9" diameter under-rail drive wheel gives positive action, no-slip traction, regardless of the load. The polyurethane tire is molded and bonded to a cast iron wheel, and is supported by prelubricated and sealed ball bearings.

TROLLEY WHEELS:

The Wright-Way tractor drive is equipped with 4" diameter flanged steel wheels with hardened tread and flange. Optional flangeless wheels and side guide rollers are available.

BEARINGS:

Each wheel includes two heavy-duty single row, pre-lubricated and permanently sealed anti-friction ball bearings. Optional guide rollers are hardened and have an extra heavy outer ring.

OPERATION:

The Wright-Way tractor drive is designed to operate on 2", 3.25" or 3.33" flange Loudon and Trambeam track. Unit will negotiate electrified SuperTrack and TrojanTrack switches, curves with a 29" or larger radius, and 505.7824, 505.7825, 505.7830 and 505.7831 latches and latch blocks. Contact the factory to discuss applications not listed.

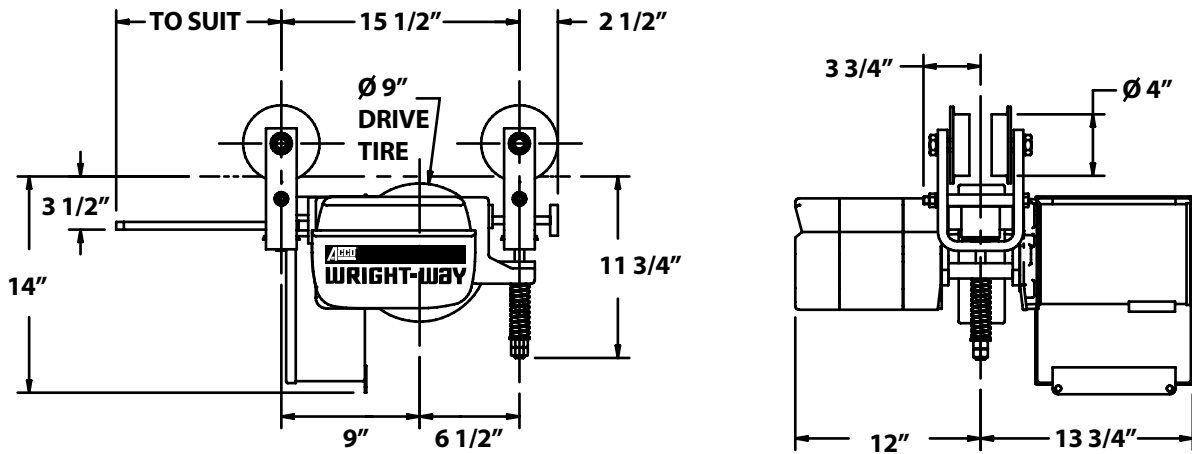

NOMINAL SPEED (FPM)	MAXIMUM TOW LOADS (LBS)	
	1/2 HP	1 HP
30	13,000	-
40	13,000	-
60	13,000	-
80	-	13,000

AVAILABLE OPTIONS:

Options available for this tractor drive include flangeless wheels with side guide rollers, bronze trolley wheels, motor brake with manual release, control pendant, special motor & control options and epoxy paint.