



ACCOLIFT®

CHAIN HOISTS & EQUIPMENT



RAPID SHIP 

Same day or next day shipping available!

Call 1-800-568-5657 to order today!

TABLE OF CONTENTS

Accolift® Clutch "CLH" Hoists

Hoist Features3
 Hook Suspension Hoists4
 Push/Pull Trolley Hoists6
 Motorized Trolley Hoists8
 Hook and Chain Bucket Dimensions10

Accolift® Hoists

Hoist Features11
 Hook Suspension Hoists12
 Push/Pull Trolley Hoists14
 Motorized Trolley Hoists16
 Hook and Chain Bucket Dimensions18

Low Headroom Hoists

Inverter Control / Motorized Trolley Hoists . .19
 Hook and Chain Bucket Dimensions20

Push-Pull End Trucks21
 Hand Chain Hoists22

Trolleys

Plain Trolleys23
 Geared Trolleys23
 Motorized Trolleys24
 Lever Hoists25
 Hand Chain and Lever Hoists
 Hook Dimensions26

FEATURES COMPARISON

ACCOLIFT® CLH

ACCOLIFT®

	ACCOLIFT® CLH	ACCOLIFT®
HOOK MOUNT	Standard	Standard
PUSH-PULL TROLLEY	Standard	Standard
MOTORIZED TROLLEY	Standard	Standard
WESTON STYLE MECHANICAL LOAD BRAKE	N/A	Standard
OVERLOAD CLUTCH	Standard	N/A
AUDIBLE OVERLOAD DEVICE	Optional	Standard
INSPECTION COVER TO INSPECT MLB	N/A	Standard
INSPECTION COVER TO INSPECT CHAIN WHEEL	Standard	N/A
SINGLE PHASE MODELS	Standard	Optional
THREE PHASE MODELS	Standard	Standard
VFD CONTROLS	Optional	Optional
RUNNING TIME METER	Standard	VFD unit only
CYCLE COUNT	Standard on ss models	N/A
UPPER LIMIT SWITCH	Micro Switch	Micro Switch
LOWER LIMIT SWITCH	Clutch	Micro Switch
CROSS MOUNT CONNECTOR	Optional	Optional
SWIVEL TROLLEYS	N/A	Optional
WEATHER COVER	Optional	Optional
CHAIN CONTAINER	Standard	Standard
NICKEL PLATED LOAD CHAIN	Optional	Optional
STAINLESS STEEL LOAD CHAIN	Optional	Optional
SPARK RESISTANT FEATURES	Optional	Optional

ACCOLIFT® CLH HOISTS - FEATURES



Friction Clutch & Upper Limit Switch

The friction clutch is an overload protection device that prevents lifting when overloaded. When the hoist is raised to high hook, the upper limit switch activates and stops the hoist motor (up direction only). This prevents unnecessary clutch wear.



Hoist Motor Brake

Simple fast acting conical style motor brake for years of trouble free operation.



Push Button Control

Compact design to enable one-handed operation. Rated NEMA 4 protection. Mushroom on/off button included. Push button cable has strain relief built in to prevent cable damage.



Electric Control Panel

Single speed hoists are reconnectable for 115/208/230V on single phase hoists and 208/230/460V on three phase hoists. Single speed controls include a running time meter and counter for hoist motion. Controls are housed in a NEMA 12 enclosure. Standard control transformer output is 115V with an option available for 48V. Standard power supply cord length is 15'.



Variable Frequency Drive

VFD hoists are available programmed for 2-speed operation. VFD hoists can be supplied for 230-1-60, 208/230-3-60 and 460-3-60 power supplies. Inverter provides run time for maintenance operations.



Heavy-Duty Hoist Motor

The hoist motor is a high torque design and is rated 30-minute duty (single phase, single speed motors are rated 20-minute). Class F motor insulation and standard thermal motor protection is included.



Load Sheave / Chain Guide

Full floating chain guide assures proper engagement of chain on load sheave. Load Sheave features 5 pockets for smoother operation and better distribution of the load. Hoist body includes a port for visual inspection of the load sheave.



Load Chain

Grade 80 load chain is case hardened and has a high resistance to wear and corrosion. All hoists are stocked with 20 feet of lift. Longer lifts are available per requirement. Nickel Plated load chain and Stainless Steel load chain is available as an option.



Hooks

Load hook is a forged carbon steel hook with a heavy-duty hook latch. Thrust bearing in hook allows 360° rotation to prevent twisting of load chain. Top hook, for hook suspended hoists, is nonrotating. Bullard hooks, Stainless Steel hooks and Bronze hooks are available as an option.



Chain Container

Chain container is standard equipment and is molded with thick polypropylene material to securely contain the chain and chain lubricant. Optional canvas containers and engineered containers for long lift applications are available as an option.



Gear Box / Oil Lubrication

The gearbox utilizes an alloy steel helical and spur gear reduction. Gear lubrication is easily accessible from the top of the hoist. The gearbox includes an inspection port for the chain pocket wheel. Food grade oil is available as an option.



Push / Pull Trolley

Trolley is adjustable for a range of 3.25" to 12" flange widths with no additional materials required. Side guide rollers are included to promote smooth trolley motion and to minimize wheel and beam wear. Wheels are dual tread design for operation on tapered or flat flange beams. Trolleys include drop down lugs and rubber bumpers as standard equipment.



Motorized Trolley

Trolley is adjustable for a range of 3.25" to 12" flange widths with no additional materials required. Side guide rollers are included to promote smooth trolley motion and to minimize wheel and beam wear. Wheels are dual tread design for operation on tapered or flat flange beams. Trolleys include drop down lugs and rubber bumpers as standard equipment. Trolley motor includes class F insulation and a disc type motor brake. Motor is rated for 30-minute duty (single phase, single speed motors are rated 20-minute) and includes standard thermal motor protection.

ACCOLIFT® CLH HOISTS - HOOK SUSPENSION

SINGLE PHASE / SINGLE SPEED HOOK SUSPENSION

Cap. (Tons)	Model Number	Std. Lift (ft.)	Push Button Cord Length (ft.)	Lifting Speed (fpm)	Hoist Motor			Load Chain Diameter (in.) X Chain Fall Lines	Add'l 1 ft. of Lift (lbs.)	Net Wt. (lbs.)
					HP	Amp. Draw				
						115V	208/230V			
1/2	2330010	20	18	14	1.1	24.0	13.1/12.0	.280 x (1)	0.75	139
1	2330020			14	1.1	24.0	13.1/12.0	.280 x (1)	0.75	139
2	2330040			7	1.1	24.0	13.1/12.0	.280 x (2)	1.5	172

SINGLE PHASE / INVERTER CONTROL HOOK SUSPENSION

Cap. (Tons)	Model Number	Std. Lift (ft.)	Push Button Cord Length (ft.)	Lifting Speed (fpm)	Hoist Motor			Load Chain Diameter (in.) X Chain Fall Lines	Add'l 1 ft. of Lift (lbs.)	Net Wt. (lbs.)
					HP	Amp. Draw				
						115V	208/230V			
1/2	2330010-VFD-230-1	20	18	27/9	2.4	-	9.2/8.4	.280 x (1)	0.75	148
1	2330020-VFD-230-1			27/9	2.4	-	9.2/8.4	.280 x (1)	0.75	148
2	2330040-VFD-230-1			13/4	2.4	-	9.2/8.4	.280 x (2)	1.5	181
3	See model 2130060-VFD-230-1 on page 12.									

THREE PHASE / SINGLE SPEED HOOK SUSPENSION

Cap. (Tons)	Model Number	Std. Lift (ft.)	Push Button Cord Length (ft.)	Lifting Speed (fpm)	Hoist Motor			Load Chain Diameter (in.) X Chain Fall Lines	Add'l 1 ft. of Lift (lbs.)	Net Wt. (lbs.)
					HP	Amp. Draw				
						208/230V	460V			
1/2	2230010	20	18	17	2.0	8.8/8.0	4.0	.280 x (1)	0.75	134
1	2230020			17	2.0	8.8/8.0	4.0	.280 x (1)	0.75	134
2	2230040			9	2.0	8.8/8.0	4.0	.280 x (2)	1.5	168

THREE PHASE / INVERTER CONTROL HOOK SUSPENSION

Cap. (Tons)	Model Number	Std. Lift (ft.)	Push Button Cord Length (ft.)	Lifting Speed (fpm)	Hoist Motor			Load Chain Diameter (in.) X Chain Fall Lines	Add'l 1 ft. of Lift (lbs.)	Net Wt. (lbs.)
					HP	Amp. Draw				
						208/230V	460V			
1/2	2230010-VFD	20	18	27/9	2.4	9.2/8.4	4.2	.280 x (1)	0.75	146
1	2230020-VFD			27/9	2.4	9.2/8.4	4.2	.280 x (1)	0.75	146
2	2230040-VFD			13/4	2.4	9.2/8.4	4.2	.280 x (2)	1.5	181

DIMENSIONS - HOOK SUSPENSION

Figure A

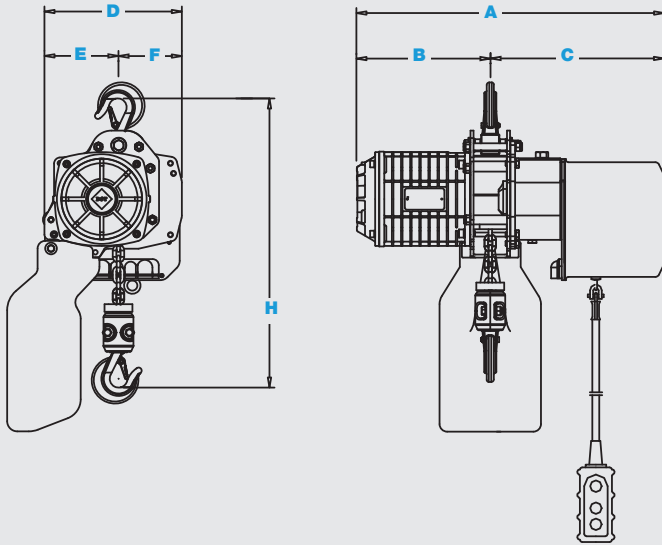
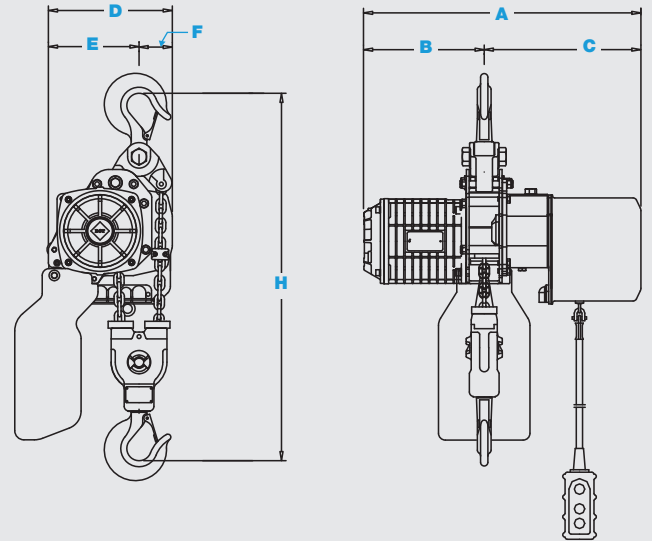

Figure B



Dimensions in Inches (Nominal). *For hook dimensions, see page 10.*

Model Number	A	B	C	D	E	F	H	Figure
2230010	20.7	10.4	10.3	10.7	5.8	4.9	15.8	A
2230020	20.7	10.4	10.3	10.7	5.8	4.9	15.8	A
2230040	20.7	10.4	10.3	10.7	7.8	2.9	26.8	B
2230010-VFD	23.9	10.4	13.5	13	5.8	7.2	15.8	A
2230020-VFD	23.9	10.4	13.5	13	5.8	7.2	15.8	A
2230040-VFD	23.9	10.4	13.5	13	7.8	5.2	26.8	B
2330010	21.5	10.4	11.1	10.7	5.8	4.9	15.8	A
2330020	21.5	10.4	11.1	10.7	5.8	4.9	15.8	A
2330040	21.5	10.4	11.1	10.7	7.8	2.9	26.8	B
2330010-VFD-230-1	23.9	10.4	13.5	10.7	5.8	4.9	15.8	A
2330020-VFD-230-1	23.9	10.4	13.5	10.7	5.8	4.9	15.8	A
2330040-VFD-230-1	23.9	10.4	13.5	10.7	7.8	2.9	26.8	B

ACCOLIFT® CLH HOISTS - PUSH / PULL TROLLEY

SINGLE PHASE / SINGLE SPEED PUSH / PULL TROLLEY

Cap. (Tons)	Model Number	Std. Lift (ft.)	Push Button Cord Length (ft.)	Lifting Speed (fpm)	Hoist Motor			Flange Width Adjustability (in.)	Wheel Diameter (in.)	Min. Beam Radius (in.)	Load Chain Diameter (in.) X Chain Fall Lines	Add'l 1 ft. of Lift (lbs.)	Net Wt. (lbs.)
					HP	Amp. Draw							
						115V	208/ 230V						
1/2	2330010-PT	20	18	14	1.1	24.0	13.1/12.0	3.25 to 12	3.7	32	.280 x (1)	0.75	161
1	2330020-PT			14	1.1	24.0	13.1/12.0	3.25 to 12	3.7	32	.280 x (1)	0.75	161
2	2330040-PT			7	1.1	24.0	13.1/12.0	3.25 to 12	4.3	32	.280 x (2)	1.5	209

SINGLE PHASE / INVERTER CONTROL PUSH / PULL TROLLEY

Cap. (Tons)	Model Number	Std. Lift (ft.)	Push Button Cord Length (ft.)	Lifting Speed (fpm)	Hoist Motor			Flange Width Adjustability (in.)	Wheel Diameter	Min. Beam Radius (in.)	Load Chain Diameter (in.) X Chain Fall Lines	Add'l 1 ft. of Lift (lbs.)	Net Wt. (lbs.)
					HP	Amp. Draw							
						208/ 230V							
1/2	2330010-VFD-230-1-PT	20	18	27/9	2.4	9.2/8.4		3.25 to 12	3.7	32	.280 x (1)	0.75	157
1	2330020-VFD-230-1-PT			27/9	2.4	9.2/8.4		3.25 to 12	3.7	32	.280 x (1)	0.75	157
2	2330040-VFD-230-1-PT			13/4	2.4	9.2/8.4		3.25 to 12	4.3	32	.280 x (2)	1.5	205
3	See model 2130060-VFD-230-1-PT on page 14.												

THREE PHASE / SINGLE SPEED PUSH / PULL TROLLEY

Cap. (Tons)	Model Number	Std. Lift (ft.)	Push Button Cord Length (ft.)	Lifting Speed (fpm)	Hoist Motor			Flange Width Adjustability (in.)	Wheel Diameter (in.)	Min. Beam Radius (in.)	Load Chain Diameter (in.) X Chain Fall Lines	Add'l 1 ft. of Lift (lbs.)	Net Wt. (lbs.)
					HP	Amp. Draw							
						208/ 230V	460V						
1/2	2230010-PT	20	18	17	2.0	8.8/8.0	4.0	3.25 to 12	3.7	32	.280 x (1)	0.75	167
1	2230020-PT			17	2.0	8.8/8.0	4.0	3.25 to 12	3.7	32	.280 x (1)	0.75	167
2	2230040-PT			9	2.0	8.8/8.0	4.0	3.25 to 12	4.3	32	.280 x (2)	1.5	216

THREE PHASE / INVERTER CONTROL PUSH / PULL TROLLEY

Cap. (Tons)	Model Number	Std. Lift (ft.)	Push Button Cord Length (ft.)	Lifting Speed (fpm)	Hoist Motor			Flange Width Adjustability (in.)	Wheel Diameter	Min. Beam Radius (in.)	Load Chain Diameter (in.) X Chain Fall Lines	Add'l 1 ft. of Lift (lbs.)	Net Wt. (lbs.)
					HP	Amp. Draw							
						208/ 230V	460V						
1/2	2230010-VFD-PT	20	18	27/9	2.4	9.2/8.4	4.2	3.25 to 12	3.7	32	.280 x (1)	0.75	167
1	2230020-VFD-PT			27/9	2.4	9.2/8.4	4.2	3.25 to 12	3.7	32	.280 x (1)	0.75	167
2	2230040-VFD-PT			13/4	2.4	9.2/8.4	4.2	3.25 to 12	4.3	32	.280 x (2)	1.5	216

DIMENSIONS - PUSH / PULL TROLLEY

Figure A

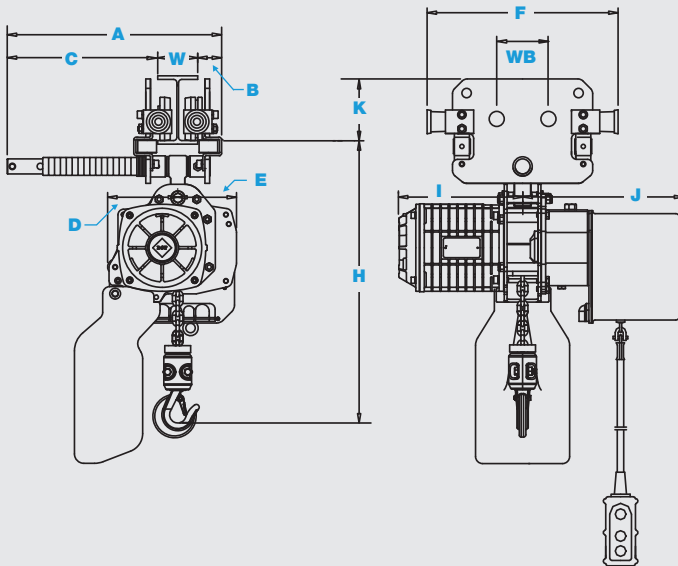
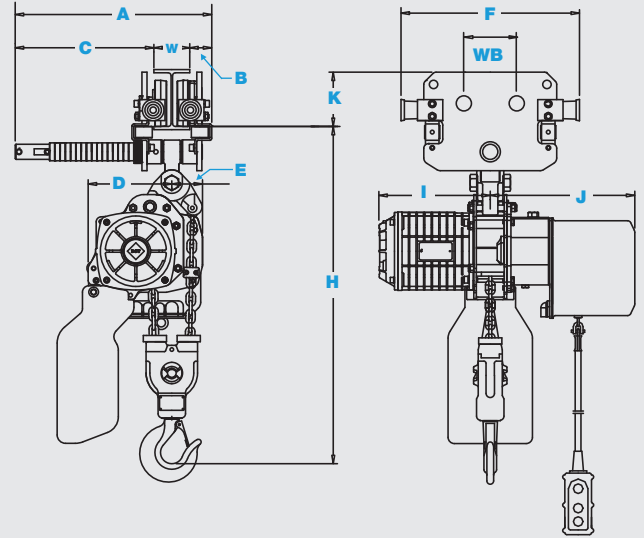

Figure B



Dimensions in Inches (Nominal). **For hook dimensions, see page 10.**

Model Number	A	B	C	D	E	F	H	I	J	K	WB	Figure
			W = Beam width									
2230010-PT	17	1.8	15.2-W	5.8	4.9	16	17.5	10.4	10.3	5.2	4.4	A
2230020-PT	17	1.8	15.2-W	5.8	4.9	16	17.5	10.4	10.3	5.2	4.4	A
2230040-PT	17.5	1.8	15.7-W	7.8	2.9	16.7	26	10.4	10.3	5.2	4.9	B
2230010-VFD-PT	17	1.8	15.2-W	5.8	7.1	16	17.5	10.4	13.5	5.2	4.4	A
2230020-VFD-PT	17	1.8	15.2-W	5.8	7.1	16	17.5	10.4	13.5	5.2	4.4	A
2230040-VFD-PT	17.5	1.8	15.7-W	7.8	5.1	16.7	26	10.4	13.5	5.2	4.9	B
2330010-PT	17	1.8	15.2-W	5.8	4.9	16	17.5	10.4	11.1	5.2	4.4	A
2330020-PT	17	1.8	15.2-W	5.8	4.9	16	17.5	10.4	11.1	5.2	4.4	A
2330040-PT	17.5	1.8	15.7-W	7.8	2.9	16.7	26	10.4	11.1	5.2	4.9	B
2330010-VFD-1-PT	17	1.8	15.2-W	5.8	4.9	16	17.5	10.4	13.5	5.2	4.4	A
2330020-VFD-1-PT	17	1.8	15.2-W	5.8	4.9	16	17.5	10.4	13.5	5.2	4.4	A
2330040-VFD-1-PT	17.5	1.8	15.7-W	7.8	2.9	16.7	26	10.4	13.5	5.2	4.9	B

ACCOLIFT® CLH HOISTS - MOTORIZED TROLLEY

SINGLE PHASE / SINGLE SPEED MOTORIZED TROLLEY

Cap. (Tons)	Model Number	Std. Lift (ft.)	Push Button Cord Length (ft.)	Lifting Speed (fpm)	Trolley Speed (fpm)	Hoist Motor			Trolley Motor			Flange Width Adjustability (in.)	Wheel Dia.	Min. Beam Radius (in.)	Load Chain Diameter (in.) X Chain Fall Lines	Add'l 1 ft. of Lift (lbs.)	Net Wt. (lbs.)
						HP	Amp. Draw		HP	Amp. Draw							
							115V	208/230V		115V	208/230V						
1/2	2330110	20	18	14	36	1.1	24.0	13.1/12.0	0.27	7.8	4.3/3.9	3.25 to 12	3.7	32	.280 x (1)	0.75	225
1	2330120			14	36	1.1	24.0	13.1/12.0	0.27	7.8	4.3/3.9	3.25 to 12	3.7	32	.280 x (1)	0.75	225
2	2330140			7	36	1.1	24.0	13.1/12.0	0.27	7.8	4.3/3.9	3.25 to 12	4.3	32	.280 x (2)	1.5	273

SINGLE PHASE / INVERTER CONTROL MOTORIZED TROLLEY

Cap. (Tons)	Model Number	Std. Lift (ft.)	Push Button Cord Length (ft.)	Lifting Speed (fpm)	Trolley Speed (fpm)	Hoist Motor			Trolley Motor			Flange Width Adjustability (in.)	Wheel Dia.	Min. Beam Radius (in.)	Load Chain Diameter (in.) X Chain Fall Lines	Add'l 1 ft. of Lift (lbs.)	Net Wt. (lbs.)
						HP	Amp. Draw		HP	Amp. Draw							
							115V	208/230V		115V	208/230V						
1/2	2330110-VFD-230-1	20	18	27/9	75/25	2.4	-	9.2/8.4	0.54	-	3.3/3.0	3.25 to 12	3.7	32	.280 x (1)	0.75	227
1	2330120-VFD-230-1			27/9	75/25	2.4	-	9.2/8.4	0.54	-	3.3/3.0	3.25 to 12	3.7	32	.280 x (1)	0.75	227
2	2330140-VFD-230-1			13/4	75/25	2.4	-	9.2/8.4	0.54	-	3.3/3.0	3.25 to 12	4.3	32	.280 x (2)	1.5	280
3	See model 2130160-VFD-230-1 on page 16.																

THREE PHASE / SINGLE SPEED MOTORIZED TROLLEY

Cap. (Tons)	Model Number	Std. Lift (ft.)	Push Button Cord Length (ft.)	Lifting Speed (fpm)	Trolley Speed (fpm)	Hoist Motor			Trolley Motor			Flange Width Adjustability (in.)	Wheel Dia.	Min. Beam Radius (in.)	Load Chain Diameter (in.) X Chain Fall Lines	Add'l 1 ft. of Lift (lbs.)	Net Wt. (lbs.)
						HP	Amp. Draw		HP	Amp. Draw							
							208/230V	460V		208/230V	460V						
1/2	2230110	20	18	17	36	2.0	8.8/8.0	4.0	0.54	3.3/3.0	1.5	3.25 to 12	3.7	32	.280 x (1)	0.75	221
1	2230120			17	36	2.0	8.8/8.0	4.0	0.54	3.3/3.0	1.5	3.25 to 12	3.7	32	.280 x (1)	0.75	221
2	2230140			9	36	2.0	8.8/8.0	4.0	0.54	3.3/3.0	1.5	3.25 to 12	4.3	32	.280 x (2)	1.5	269

THREE PHASE / INVERTER CONTROL MOTORIZED TROLLEY

Cap. (Tons)	Model Number	Std. Lift (ft.)	Push Button Cord Length (ft.)	Lifting Speed (fpm)	Trolley Speed (fpm)	Hoist Motor			Trolley Motor			Flange Width Adjustability (in.)	Wheel Dia.	Min. Beam Radius (in.)	Load Chain Diameter (in.) X Chain Fall Lines	Add'l 1 ft. of Lift (lbs.)	Net Wt. (lbs.)
						HP	Amp. Draw		HP	Amp. Draw							
							208/230V	460V		208/230V	460V						
1/2	2230110-VFD	20	18	27/9	75/25	2.4	9.2/8.4	4.2	0.54	3.3/3.0	1.5	3.25 to 12	3.7	32	.280 x (1)	0.75	231
1	2230120-VFD			27/9	75/25	2.4	9.2/8.4	4.2	0.54	3.3/3.0	1.5	3.25 to 12	3.7	32	.280 x (1)	0.75	231
2	2230140-VFD			13/4	75/25	2.4	9.2/8.4	4.2	0.54	3.3/3.0	1.5	3.25 to 12	4.3	32	.280 x (2)	1.5	280

DIMENSIONS - MOTORIZED TROLLEY

Figure A

Figure B

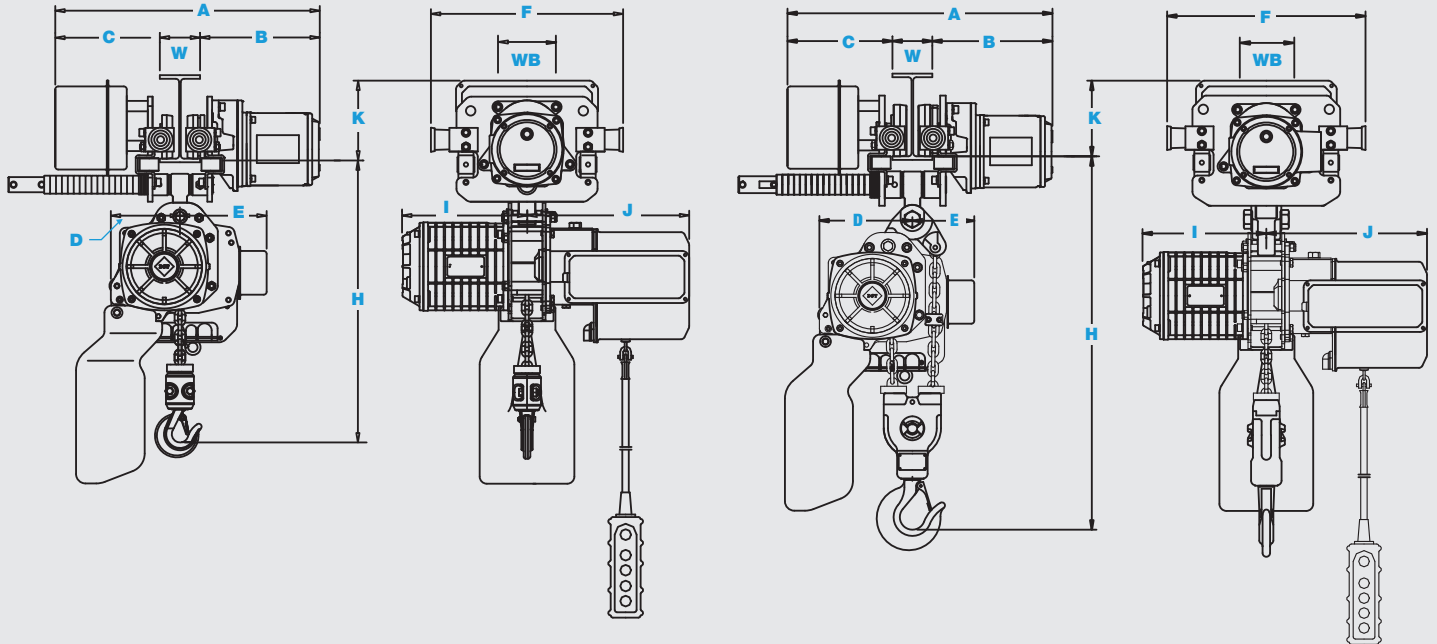

Dimensions in Inches (Nominal). *For hook dimensions, see page 10.*

Model Number	A	B	C	D	E	F	H	I	J	K	WB	Figure
2230110	16.7 + W	10	6.7	5.8	4.9	16	17.5	10.4	10.3	6.5	4.4	A
2230120	16.7 + W	10	6.7	5.8	4.9	16	17.5	10.4	10.3	6.5	4.4	A
2230140	16.9 + W	10.1	6.8	7.8	2.9	16.7	26	10.4	10.3	6.4	4.9	B
2230110-VFD	18.7 + W	10	8.7	5.8	7.2	16	17.5	10.4	13.5	6.5	4.4	A
2230120-VFD	18.7 + W	10	8.7	5.8	7.2	16	17.5	10.4	13.5	6.5	4.4	A
2230140-VFD	18.9 + W	10.1	8.8	7.8	5.2	16.7	26	10.4	13.5	6.4	4.9	B
2330110	20.3 + W	11.6	8.7	5.8	4.9	16	17.5	10.4	11.1	6.5	4.4	A
2330120	20.3 + W	11.6	8.7	5.8	4.9	16	17.5	10.4	11.1	6.5	4.4	A
2330140	20.6 + W	11.8	8.8	7.8	2.9	16.7	26	10.4	11.1	6.4	4.9	B
2330110-VFD-230-1	18.7 + W	10	8.7	5.8	4.9	16	17.5	10.4	13.5	6.5	4.4	A
2330120-VFD-230-1	18.7 + W	10	8.7	5.8	4.9	16	17.5	10.4	13.5	6.5	4.4	A
2330140-VFD-230-1	18.9 + W	10.1	8.8	7.8	2.9	16.7	26	10.4	13.5	6.4	4.9	B

ACCOLIFT® CLH HOISTS - HOOK DIMENSIONS & CHAIN CONTAINER CAPACITIES

ACCOLIFT® CLH HOISTS - HOOK DIMENSIONS

Dimensions in Inches (Nominal)

Capacity	A	B	C	D	E
1/2 Ton	0.95	3.82	1.24	1.38	0.93
1 Ton	0.95	3.82	1.24	1.38	0.93
2 Ton	1.18	5.73	1.69	2.11	1.54

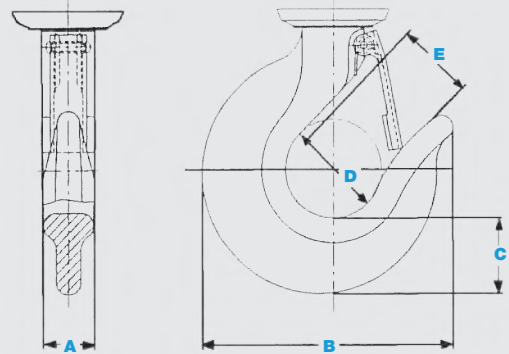

ACCOLIFT® CLH HOISTS - CHAIN CONTAINER CAPACITIES

Hoist Capacity	Max. Lift With Standard Chain Bucket (ft.)	Max. Lift With Optional Chain Bucket (ft.)	Max. Lift With Optional Canvas Chain Bag (ft.)
1/2 Ton	39 (71964-107)	49 (71574-1038)	40 (71574-1264)
1 Ton	39 (71964-107)	49 (71574-1038)	40 (71574-1264)
2 Ton	25 (71964-207) or	65 (71574-1039)	20 (71574-1264)

Buckets may be available for longer lifts than stated above - please call factory with your application.

ACCOLIFT® HOISTS - FEATURES



Weston Style Mechanical Load Brake

Weston Style Mechanical Load Brake, working in conjunction with disc type motor brake, provides a dual braking system for load lowering control. Mechanical Load Brake can easily be inspected thru the inspection port provided on the top of the gearbox.

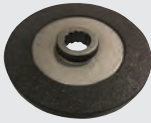

Hoist Motor Brake

Hoist motor brake is a direct acting DC rectified brake with exceptional stopping power providing cooler operating temperatures for the motor. Electric brake is designed for easy access and simple maintenance.



Overload Alert

Overload Alert is a current sensing device that stops the up motion of the hoist and sets off an audible alarm when the hoist motor draws too many amps due to an overload condition. When the hoist is lowered, the alarm stops and the overload device is reset.



Push Button Control

Compact design to enable one-handed operation. Rated NEMA 4 protection. Mushroom on/off button included. Push button cable has strain relief built in to prevent cable damage.



Electric Control Panel

Single speed hoists are reconnectable for 208/230/460V power supply. Controls are housed in a NEMA12 enclosure. Standard control transformer output is 115V with an option available for 48V. Standard power supply cord length is 15'.



Variable Frequency Drive

VFD hoists are available programmed for 2-speed operation. VFD hoists can be supplied for 230-1-60, 208/230-3-60 and 460-3-60 power supplies. Inverter provides run time for maintenance operations.



Heavy-Duty Hoist Motor

The hoist motor is a high torque design and is rated 30-minute duty. Class F motor insulation and standard thermal motor protection is included.



Load Sheave / Chain Guide

Full floating chain guide assures proper engagement of chain on load sheave. Load Sheave features 4 or 5 pockets (depending on model) for better distribution of the load.



Load Chain

Grade 80 load chain is case hardened and has a high resistance to wear and corrosion. All hoists are stocked with 20 feet of lift. Longer lifts are available per requirement. Nickel Plated load chain and Stainless Steel load chain is available as an option.



Hooks

Load hook is a forged carbon steel hook with a heavy-duty hook latch. Thrust bearing in load hook allows 360° rotation to prevent twisting of load chain. Top hook, for hook suspended hoists, is nonrotating. Bullard hooks, Stainless Steel hooks and Bronze hooks are available for some models as an option. Contact factory.



Chain Container

Chain container is standard equipment and is either molded with thick polypropylene material or fabricated from steel to securely contain the chain and chain lubricant. Optional canvas containers and engineered containers for long lift applications are available as an option.



Gear Box / Oil Lubrication

The gearbox utilizes an alloy steel helical and spur gear reduction. An access port is included on the top of the gear box to allow visual inspection of the mechanical load brake. Lubrication is easily maintained from the top of the hoist.



Push / Pull Trolley

Trolley is adjustable for a range of 3.25" to 12" flange widths with no additional materials required. Side guide rollers are included to promote smooth trolley motion and to minimize wheel and beam wear. Wheels are dual tread design for operation on tapered or flat flange beams. Trolleys include drop down lugs and rubber bumpers as standard equipment.



Motorized Trolley

Trolley is adjustable for a range of 3.25" to 12" flange widths for the majority of models (excluding 7.5T, 15T and 20T models) with no additional materials required. Side guide rollers are included to promote smooth trolley motion and to minimize wheel and beam wear. Wheels are dual tread design for operation on tapered or flat flange beams. Trolleys include drop down lugs and rubber bumpers as standard equipment. Trolley motor includes class F insulation and a disc type motor brake. Motor is rated for 30-minute duty and includes standard thermal motor protection.

ACCOLIFT® HOISTS - HOOK SUSPENSION

SINGLE SPEED HOOK SUSPENSION

Cap. (Tons)	Model Number	Std. Lift (ft.)	Push Button Cord Length (ft.)	Lifting Speed (fpm)	Hoist Motor			Load Chain Diameter (in.) X Chain Fall Lines	Add'l 1 ft. of Lift (lbs.)	Net Wt. (lbs.)
					HP	Amp. Draw				
						208/230V	460V			
1	2130020	20	18	17	2.0	8.8/8.0	4.0	.280 x (1)	0.75	165
1	2130030			27	2.4	9.2/8.4	4.2	.280 x (1)	0.75	165
2	2130040			13	2.4	9.2/8.4	4.2	.280 x (2)	1.5	198
2	2130050			27	4.7	17.2/15.8	7.9	.441 x (1)	1.84	282
3	2130060			17	4.7	17.2/15.8	7.9	.374 x (2)	2.62	337
3	2130065			21	4.7	17.2/15.8	7.9	.441 x (1)	1.84	286
5	2130070			11	4.7	17.2/15.8	7.9	.441 x (2)	3.68	384
7.5	2130075			7	4.7	17.2/15.8	7.9	.441 x (3)	5.52	536
10	2130080			11	4.7 x (2)	34.4/31.6	15.8	.441 x (4)	7.36	964
15	2130090			7	4.7 x (2)	34.4/31.6	15.8	.441 x (6)	11.04	1786
20	2130095			6	4.7 x (2)	34.4/31.6	15.8	.441 x (8)	14.72	2030

INVERTER CONTROL HOOK SUSPENSION

Cap. (Tons)	Model Number	Std. Lift (ft.)	Push Button Cord Length (ft.)	Lifting Speed (fpm)	Hoist Motor			Load Chain Diameter (in.) X Chain Fall Lines	Add'l 1 ft. of Lift (lbs.)	Net Wt. (lbs.)
					HP	Amp. Draw				
						208/230V	460V			
1	2130030-VFD	20	18	21/7	2.4	9.2/8.4	4.2	.280 x (1)	0.75	165
2	2130050-VFD			21/7	4.7	18.4/16.8	7.9	.441 x (1)	1.84	282
3	2130060-VFD			15/5	4.7	18.4/16.8	7.9	.374 x (2)	2.62	337
3	2130060-VFD-230-1			15/5	4.7	18.4/16.8	-	.374 x (2)	2.62	337
3	2130065-VFD			21/7	4.7	18.4/16.8	7.9	.441 x (1)	1.84	286
5	2130070-VFD			11/4	4.7	18.4/16.8	7.9	.441 x (2)	3.68	384
7.5	2130075-VFD			7/3	4.7	18.4/16.8	7.9	.441 x (3)	5.52	536
10	2130080-VFD			11/4	4.7 x (2)	34.4/31.6	15.8	.441 x (4)	7.36	964
15	2130090-VFD			7/3	4.7 x (2)	34.4/31.6	15.8	.441 x (6)	11.04	1786
20	2130095-VFD			6/2	4.7 x (2)	34.4/31.6	15.8	.441 x (8)	14.72	2030

DIMENSIONS - HOOK SUSPENSION

1 TO 5 TON HOOK SUSPENSION HOISTS:

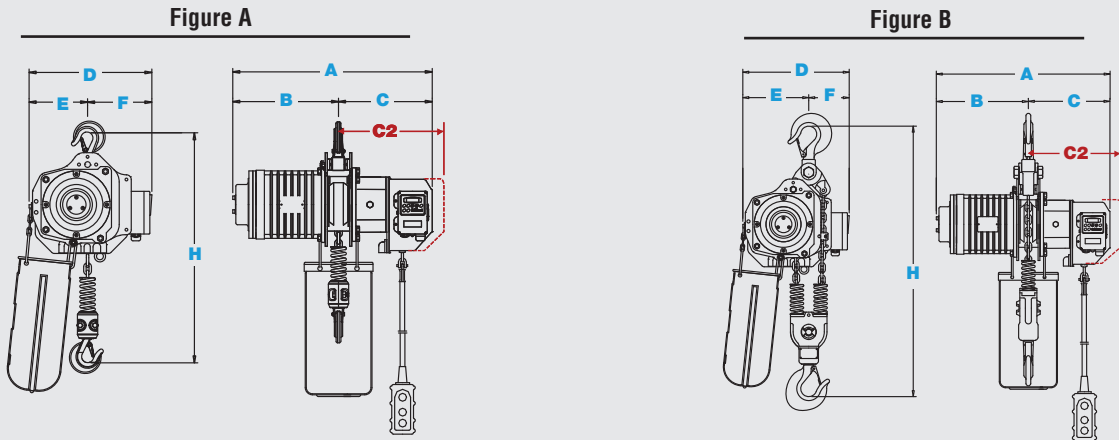

Dimensions in Inches (Nominal). *For hook dimensions, see page 18.*

Model Number	A	B	C	C2*	D	E	F	H	Figure
2130020	22.9	12.1	10.8	-	14.2	6.7	7.5	20	A
2130030	22.9	12.1	10.8	12.8	14.2	6.7	7.5	20	A
2130040	22.9	12.1	10.8	-	14.2	8.9	5.3	30	B
2130050	26.4	14.1	12.3	13.5	16.8	7.7	9.1	28.5	A
2130060	26.4	14.1	12.3	13.5	16.8	10.2	6.6	36	B
2130060-VFD-230-1	27.6	14.1	13.5	13.5	16.8	10.2	6.6	36	B
2130065	26.4	14.1	12.3	13.5	16.8	7.7	9.1	30	A
2130070	26.4	14.1	12.3	13.5	16.8	10.7	6.1	42	B
2130075	26.4	14.1	12.3	13.5	21.2	12.8	8.4	57.7	C
2130080	28.2	14.1	14.1	14.1	48.8	24.4	24.4	57.4	D
2130090	30	15	15	16.2	53.9	27	27	70.4	D
2130095	31.8	15.9	15.9	17.1	53.9	27	27	70.4	D

* Inverter Control Models only.

7-1/2 TON HOOK SUSPENSION HOIST:

Figure C

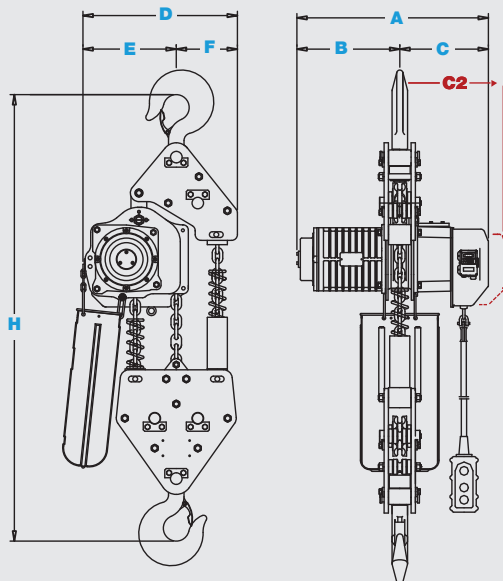

10 TON TO 20 TON HOOK SUSPENSION HOISTS:

Figure D

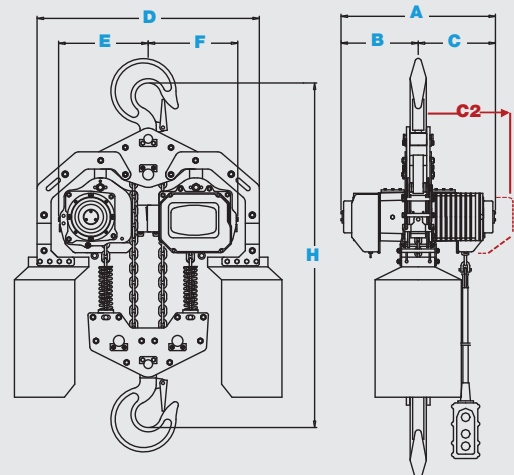

ACCOLIFT® HOISTS - PUSH / PULL TROLLEY

SINGLE SPEED PUSH / PULL TROLLEY

Cap. (Tons)	Model Number	Std. Lift (ft.)	Push Button Cord Length (ft.)	Lifting Speed (fpm)	Hoist Motor			Flange Width Adjustability (in.)	Wheel Diameter	Min. Beam Radius (in.)	Load Chain Diameter (in.) X Chain Fall Lines	Add'l 1 ft. of Lift (lbs.)	Net Wt. (lbs.)
					HP	Amp. Draw							
						208/ 230V	460V						
1	2130020-PT	20	18	17	2.0	8.8/8.0	4.0	3.25 to 12	3.7	32	.280 x (1)	0.75	174
1	2130030-PT			27	2.4	9.2/8.4	4.2	3.25 to 12	3.7	32	.280 x (1)	0.75	174
2	2130040-PT			13	2.4	9.2/8.4	4.2	3.25 to 12	4.3	32	.280 x (2)	1.5	229
2	2130050-PT			27	4.7	17.2/15.8	7.9	3.25 to 12	4.3	32	.441 x (1)	1.84	260
3	2130060-PT			17	4.7	17.2/15.8	7.9	3.25 to 12	4.9	40	.374 x (2)	2.62	404
3	2130065-PT			21	4.7	17.2/15.8	7.9	3.25 to 12	4.9	40	.441 x (1)	1.84	293
5	2130070-PT			11	4.7	17.2/15.8	7.9	3.25 to 12	5.5	72*	.441 x (2)	3.68	523

INVERTER CONTROL PUSH / PULL TROLLEY

Cap. (Tons)	Model Number	Std. Lift (ft.)	Push Button Cord Length (ft.)	Lifting Speed (fpm)	Hoist Motor			Flange Width Adjustability (in.)	Wheel Diameter	Min. Beam Radius (in.)	Load Chain Diameter (in.) X Chain Fall Lines	Add'l 1 ft. of Lift (lbs.)	Net Wt. (lbs.)
					HP	Amp. Draw							
						208/ 230V	460V						
1	2130030-VFD-PT	20	18	21/7	2.4	9.2/8.4	4.2	3.25 to 12	3.7	32	.280 x (1)	0.75	174
2	2130050-VFD-PT			21/7	4.7	17.2/15.8	7.9	3.25 to 12	4.3	32	.441 x (1)	1.84	260
3	2130060-VFD-PT			15/5	4.7	17.2/15.8	7.9	3.25 to 12	4.9	40	.374 x (2)	2.62	404
3	2130060-VFD-230-1-PT			15/5	4.7	17.2/15.8	-	3.25 to 12	4.9	40	.374 x (2)	2.62	404
3	2130065-VFD-PT			21/7	4.7	17.2/15.8	7.9	3.25 to 12	4.9	40	.441 x (1)	1.84	293
5	2130070-VFD-PT			11/4	4.7	17.2/15.8	7.9	3.25 to 12	5.5	72*	.441 x (2)	3.68	523

* Applies to a beam flange width of 4" and over.



DIMENSIONS - PUSH / PULL TROLLEY

1 TO 5 TON PUSH / PULL TROLLEY HOISTS:

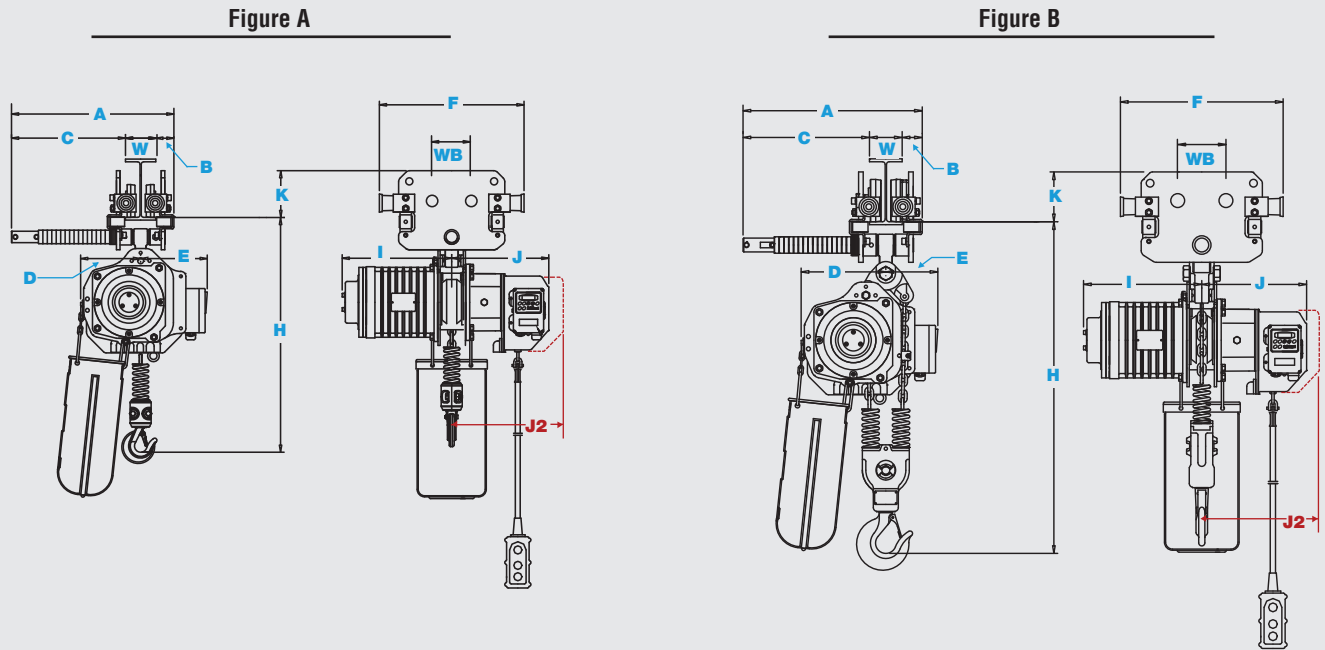

Dimensions in Inches (Nominal). *For hook dimensions, see page 18.*

Model Number	A	B	C W = Beam width	D	E	F	H	I	J	J2*	K	WB	Figure
2130020-PT	17.9	2	15.9-W	6.7	7.5	16	21.5	12.1	10.8	-	5.2	4.4	A
2130030-PT	17.9	2	15.9-W	6.7	7.5	16	21.5	12.1	10.8	12.8	5.2	4.4	A
2130040-PT	18.3	2.1	16.2-W	8.9	5.3	16.7	29.3	12.1	10.8	-	5.1	4.9	B
2130050-PT	18.3	2.1	16.2-W	7.7	9.1	16.7	28.2	14.1	12.3	13.5	5.1	4.9	A
2130060-PT	18.3	2	16.3-W	10.2	6.6	18	36.2	14.1	12.3	13.5	5.8	5.5	B
2130060-VFD-230-1-PT	18.3	2	16.3-W	10.2	6.6	18	36.2	14.1	13.5	13.5	5.8	5.5	B
2130065-PT	18.3	2	16.3-W	7.7	9.1	18	28.8	14.1	12.3	13.5	5.8	5.5	A
2130070-PT	19.2	2.2	17-W	10.7	6.1	20	41.7	14.1	12.3	13.5	5.7	6.1	B

* Inverter Control Models only.

ACCOLIFT® HOISTS - MOTORIZED TROLLEY

SINGLE SPEED MOTORIZED TROLLEY

Cap. (Tons)	Model Number	Std. Lift (ft.)	Push Button Cord Length (ft.)	Lifting Speed (fpm)	Trolley Speed (fpm)	Hoist Motor			Trolley Motor			Flange Width Adjustability (in.)	Wheel Dia.	Min. Beam Radius (in.)	Load Chain Diameter (in.) X Chain Fall Lines	Add'l 1 ft. of Lift (lbs.)	Net Wt. (lbs.)
						HP	Amp. Draw		HP	Amp. Draw							
							208/230V	460V		208/230V	460V	Standard					
1	2130120	20	18	17	36	2.0	8.8/8.0	4.0	0.54	3.3/3.0	1.5	3.25 to 12	3.7	32	.280 x (1)	0.75	238
1	2130130			27	36	2.4	9.2/8.4	4.2	0.54	3.3/3.0	1.5	3.25 to 12	3.7	32	.280 x (1)	0.75	238
2	2130140			13	36	2.4	9.2/8.4	4.2	0.54	3.3/3.0	1.5	3.25 to 12	4.3	32	.280 x (2)	1.5	293
2	2130150			27	36	4.7	17.2/15.8	7.9	0.54	3.3/3.0	1.5	3.25 to 12	4.3	32	.441 x (1)	1.84	388
3	2130160			17	33	4.7	17.2/15.8	7.9	1.0	4.8/4.4	2.2	3.25 to 12	4.9	40	.374 x (2)	2.62	507
3	2130165			21	33	4.7	17.2/15.8	7.9	1.0	4.8/4.4	2.2	3.25 to 12	4.9	40	.441 x (1)	1.84	449
5	2130170			11	33	4.7	17.2/15.8	7.9	1.0	4.8/4.4	2.2	3.25 to 12	5.5	72*	.441 x (2)	3.68	589
7.5	2130175			7	33	4.7	17.2/15.8	7.9	1.0x(2)	9.6/8.8	4.4	5 to 12	5.5	**	.441 x (3)	5.52	1124
10	2130180			11	33	4.7x(2)	34.4/31.6	15.8	1.0x(2)	9.6/8.8	4.4	3.25 to 12	5.5	**	.441 x (4)	7.36	1503
15	2130190			7	26	4.7x(2)	34.4/31.6	15.8	1.0x(2)	9.6/8.8	4.4	5.9 to 12	6.3	**	.441 x (6)	11.04	2244
20	2130195			6	26	4.7x(2)	34.4/31.6	15.8	1.0x(2)	9.6/8.8	4.4	6.5 to 12	6.3	**	.441 x (8)	14.72	2398

INVERTER CONTROL MOTORIZED TROLLEY

Cap. (Tons)	Model Number	Std. Lift (ft.)	Push Button Cord Length (ft.)	Lifting Speed (fpm)	Trolley Speed (fpm)	Hoist Motor			Trolley Motor			Flange Width Adjustability (in.)	Wheel Dia.	Min. Beam Radius (in.)	Load Chain Diameter (in.) X Chain Fall Lines	Add'l 1 ft. of Lift (lbs.)	Net Wt. (lbs.)
						HP	Amp. Draw		HP	Amp. Draw							
							208/230V	460V		208/230V	460V	Standard					
1	2130130-VFD	20	18	21/7	50/17	2.4	9.2/8.4	4.2	0.54	3.3/3.0	1.5	3.25 to 12	3.7	32	.280 x (1)	0.75	248
2	2130150-VFD			21/7	50/17	4.7	17.2/15.8	7.9	0.54	3.3/3.0	1.5	3.25 to 12	4.3	32	.441 x (1)	1.84	398
3	2130160-VFD			15/5	50/17	4.7	17.2/15.8	7.9	1.0	4.8/4.4	2.2	3.25 to 12	4.9	40	.374 x (2)	2.62	517
3	2130160-VFD-230-1			15/5	50/17	4.7	17.2/15.8	-	1.0	4.8/4.4	-	3.25 to 12	4.9	40	.374 x (2)	2.62	517
3	2130165-VFD			21/7	50/17	4.7	17.2/15.8	7.9	1.0	4.8/4.4	2.2	3.25 to 12	4.9	40	.441 x (1)	1.84	459
5	2130170-VFD			11/4	50/17	4.7	17.2/15.8	7.9	1.0	4.8/4.4	2.2	3.25 to 12	5.5	72*	.441 x (2)	3.68	599
7.5	2130175-VFD			7/3	50/17	4.7	17.2/15.8	7.9	1.0x(2)	9.6/8.8	4.4	5 to 12	5.5	**	.441 x (3)	5.52	1142
10	2130180-VFD			11/4	50/17	4.7x(2)	34.4/31.6	15.8	1.0x(2)	9.6/8.8	4.4	3.25 to 12	5.5	**	.441 x (4)	7.36	1528
15	2130190-VFD			7/3	40/13	4.7x(2)	34.4/31.6	15.8	1.0x(2)	9.6/8.8	4.4	5.9 to 12	6.3	**	.441 x (6)	11.04	2274
20	2130195-VFD			6/2	40/13	4.7x(2)	34.4/31.6	15.8	1.0x(2)	9.6/8.8	4.4	6.5 to 12	6.3	**	.441 x (8)	14.72	2428

* Applies to a beam flange width of 4" and over.

** Contact factory with application.

DIMENSIONS - MOTORIZED TROLLEY

1 TO 5 TON MOTORIZED TROLLEY HOISTS:

Figure A

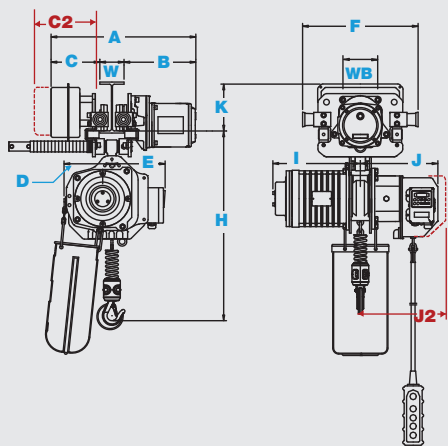
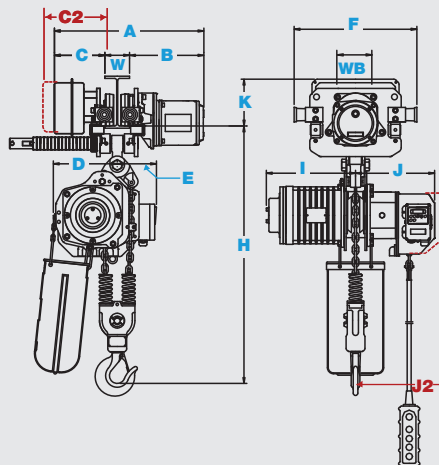

Figure B



Dimensions in Inches (Nominal). *For hook dimensions, see page 18.*

Model Number	A <small>W = Beam width</small>	B	C	C2*	D	E	F	H	I	J	J2*	K	WB	Figure
2130120	16.6 + W	9.9	6.7	-	6.7	7.5	16	21	12.1	10.8	-	6.5	4.4	A
2130130	16.6 + W	9.9	6.7	8.7	6.7	7.5	16	21	12.1	10.8	12.8	6.5	4.4	A
2130140	16.9 + W	10.1	6.8	-	8.9	5.3	16.7	29	12.1	10.8	-	6.4	4.9	B
2130150	16.9 + W	10.1	6.8	8.8	7.7	9.1	16.7	28	14.1	12.3	13.5	6.4	4.9	A
2130160	17.8 + W	10.9	6.9	8.9	10.2	6.6	18	36	14.1	12.3	13.5	6.2	5.5	B
2130160-VFD-230-1	19.8+W	10.9	8.9	8.9	10.2	6.6	18	36	14.1	13.5	13.5	6.2	5.5	B
2130165	17.8 + W	10.9	6.9	8.9	7.7	9.1	18	29	14.1	12.3	13.5	6.2	5.5	A
2130170	18.4 + W	11.2	7.2	9.2	10.7	6.1	20	42	14.1	12.3	13.5	6.3	6.1	B
2130175	18.2 + W	11.1	7.1	9.1	-	-	37.8	50	14.1	12.3	13.5	6.3	17.7	C
2130180	18.4 + W	11.2	7.2	9.2	-	-	37.4	49	14.1	14.1	14.1	6.3	17.3	D
2130190	20.3 + W	12.7	7.6	9.6	-	-	47	59	14.8	14.8	16	7.3	22.0	D
2130195	20.3 + W	12.7	7.6	9.6	-	-	47	59	15.9	15.9	17.1	7.3	22.0	D

* Inverter Control Models only.

7-1/2 TON MOTORIZED TROLLEY HOIST:

Figure C

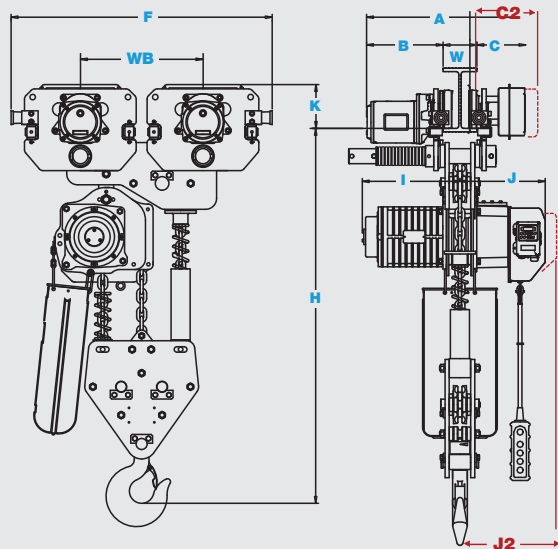

10 TON TO 20 TON MOTORIZED TROLLEY HOISTS:

Figure D

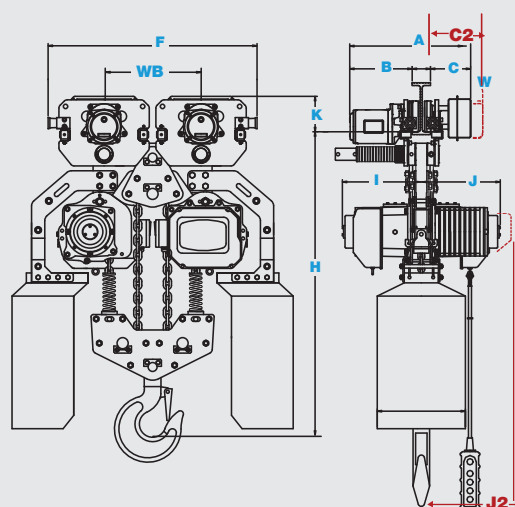

ACCOLIFT® HOISTS - HOOK DIMENSIONS & CHAIN CONTAINER CAPACITIES

ACCOLIFT® HOISTS - HOOK DIMENSIONS

Dimensions in Inches (Nominal)

Capacity	A	B	C	D	E
1 Ton	0.95	3.82	1.24	1.38	.93
2 Ton	1.18	5.73	1.69	2.11	1.54
3 Ton	1.38	6.63	1.93	2.36	1.77
5 Ton	1.71	7.48	2.17	2.76	2.21
7 1/2 Ton	2.17	9.21	3.43	3.54	3.05
10 Ton	3.15	12.72	4.65	4.72	3.35
15 Ton	3.15	12.72	4.65	4.72	3.35
20 Ton	3.15	12.72	4.65	4.72	3.35

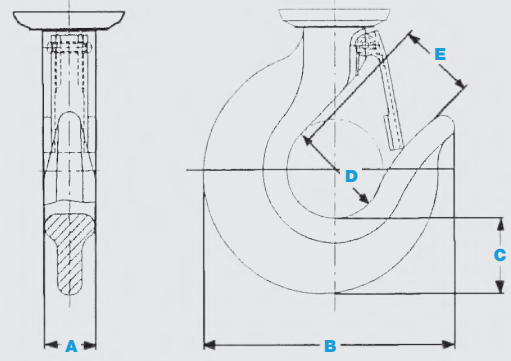

ACCOLIFT® HOISTS - CHAIN CONTAINER CAPACITIES

Model Number	Hoist Capacity	Max. Lift With Standard Chain Bucket (ft.)	Max. Lift With Optional Chain Bucket (ft.)	Max. Lift With Optional Canvas Chain Bag (ft.)
2130020 2130120	1T (17 FPM)	49 (71574-1038)	130 (71574-1039)	40 (71574-1264)
2130030 2130130	1T (27 FPM)	49 (71574-1038)	130 (71574-1039)	40 (71574-1264)
2130040 2130140	2T (13 FPM)	24 (71574-1038)	65 (71574-1039)	20 (71574-1264)
2130050 2130150	2T (27 FPM)	20 (71574-1038)	59 (71574-1039)	15 (71574-1264)
2130060 2130160	3T (17 FPM)	39 (71574-1039)	57 (71574-1293) 81 (71574-1253)	N/A
2130065 2130165	3T (21 FPM)	20 (71574-1038)	59 (71574-1039)	15 (71574-1264)
2130070 2130170	5T (11 FPM)	30 (71574-1039)	46 (71574-1293) 65 (71574-1253)	N/A
2130075 2130175	7.5T (7 FPM)	20 (71574-1039)	49 (71574-7239)	N/A
2130080 2130180	10T (11 FPM)	49 (71574-6239)	59 (71574-6239-2)	N/A
Steel buckets may be available for longer lifts than stated above - please call factory with your application. Buckets custom designed for 15T & 20T hoists as application requires.				

LOW HEADROOM HOISTS

LOW HEADROOM HOISTS - INVERTER CONTROL / MOTORIZED TROLLEY

Cap. (Tons)	Model Number	Std. Lift (ft.)	Push Button Cord Length (ft.)	Lifting Speed (fpm)	Trolley Speed (fpm)	Hoist Motor			Trolley Motor			Flange Width Adjustability (in.)	Wheel Dia.	Load Chain Diameter (in.) X Chain Fall Lines	Add'l 1 ft. of Lift (lbs.)	Net Wt. (lbs.)
						HP	Amp. Draw		HP	Amp. Draw						
							208/230V	460V		208/230V	460V					
1	2230120-VFD-L	20	18	17/6	75/25	2.0	8.8/8.0	4.0	0.54	3.3/3.0	1.5	3.25 to 12	3.7	.280 X (1)	0.75	330
2	2230140-VFD-L			9/3	75/25	2.0	8.8/8.0	4.0	0.54	3.3/3.0	1.5	3.25 to 12	4.3	.280 X (2)	1.5	378
3	2130160-VFD-L			15/5	65/22	4.7	17.2/15.8	7.9	1.0	4.8/4.4	2.2	3.25 to 12	5	.374 X (2)	2.68	617
5	2130170-VFD-L			11/4	65/22	4.7	17.2/15.8	7.9	1.0	4.8/4.4	2.2	3.25 to 12	5.5	.441 X (2)	3.68	713

Figure A

(Refer to page 3 for hoist features.)

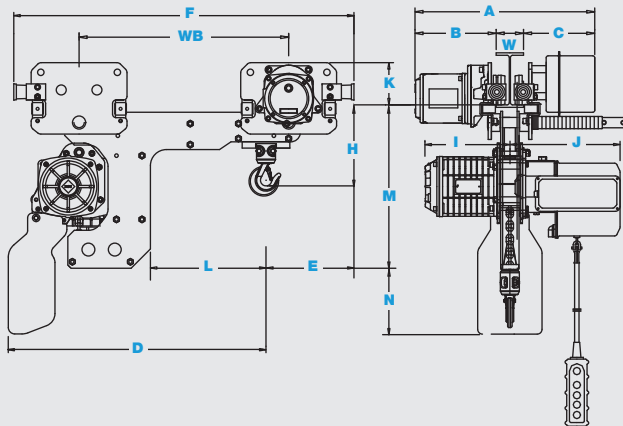

Figure B

(Refer to page 3 for hoist features.)

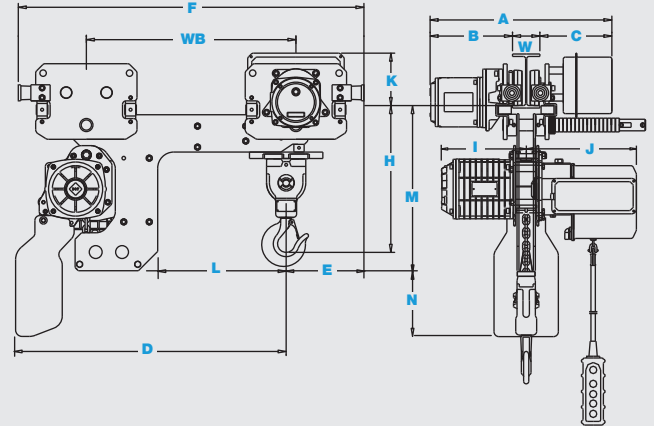
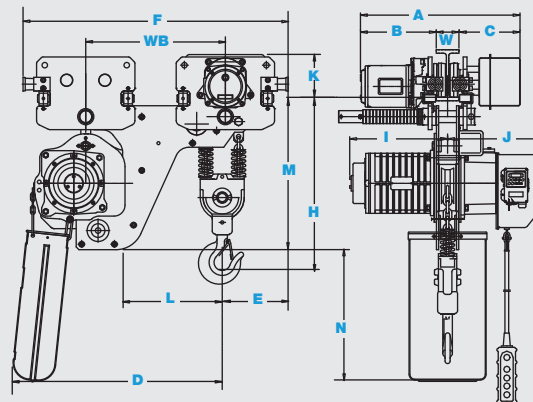

Figure C

(Refer to page 11 for hoist features.)



Dimensions in Inches (Nominal). **For hook dimensions, see page 20.**

Model Number	A	B	C	D	E	F	H	I	J	K	L	M	N	WB	Figure
2230120-VFD-L	18.5+W	10	8.5	30.7	10.8	41.5	10.3	10.4	13.5	5.2	14	20	8	25.5	A
2230140-VFD-L	18.9+W	10.1	8.8	33	9.5	42.5	17.9	10.4	13.5	5.2	15	20	8	25.5	B
2130160-VFD-L	19.6+W	10.9	8.7	28.6	9.6	38.2	23.6	14.1	13.5	5.8	15	22	19	20	C
2130170-VFD-L	20.4+W	11.2	9.2	30.1	10	40.1	27.2	14.1	13.5	6.1	15	22.4	19	20	C

LOW HEADROOM HOISTS

LOW HEADROOM HOISTS - HOOK DIMENSIONS

Dimensions in Inches (Nominal)

Capacity	A	B	C	D	E
1 Ton	0.95	3.82	1.24	1.38	0.93
2 Ton	1.18	5.73	1.69	2.11	1.54
3 Ton	1.38	6.63	1.93	2.36	1.77
5 Ton	1.71	7.48	2.17	2.76	2.21

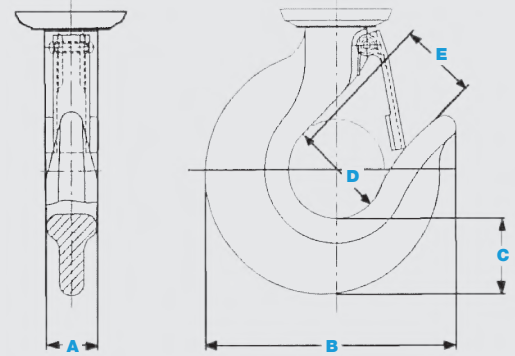

LOW HEADROOM HOISTS - CHAIN CONTAINER CAPACITIES

Model Number	Hoist Capacity	Max. Lift With Standard Chain Bucket (ft.)	Max. Lift With Optional Chain Bucket (ft.)	Max. Lift With Optional Canvas Chain Bag (ft.)
2230120-VFD-L	1T	39 (71964-1132)	49 (71574-1038)	40 (71574-1264)
2230140-VFD-L	2T	25 (71965-2132) or (71574-1038)	65 (71574-1039)	20 (71574-1264)
2130160-VFD-L	3T	39 (71574-1039)	57 (71574-1293) 81 (71574-1253)	N/A
2130170-VFD-L	5T	30 (71574-1039)	46 (71574-1293) 65 (71574-1253)	N/A



SERIES 421 PUSH-PULL END TRUCKS

For Underhung Single Girder Cranes

Designed for light or medium loads, Series 421 Push-Pull End Trucks are the basic component for easy-to-assemble underhung cranes.

- Furnished with heat treated gray iron wheels for 2 ton maximum crane capacities.
- Maximum crane span is 25'-0".
- End truck frames include drop lugs.
- Wheels are 4" diameter, flanged, dual tread permitting operation on standard "I" beams or flat flange beams. Wheels incorporate shielded, lifetime lubricated, single row ball bearings.
- End trucks are shipped with crane fabrication instructions and mounting hardware. Bridge beam and end stops are by others.

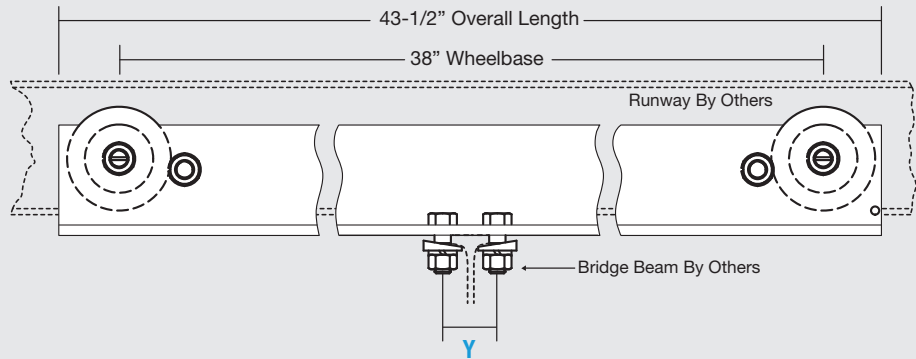
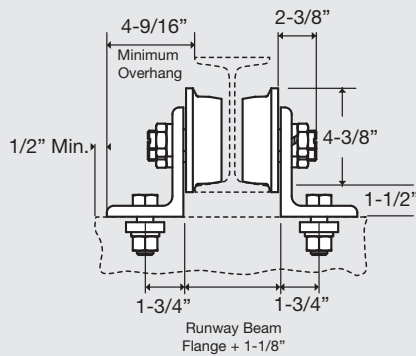
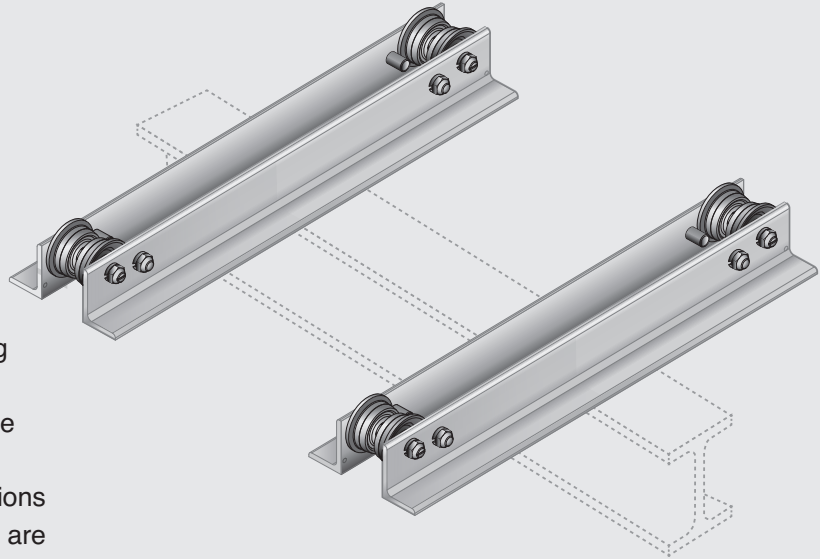

Model Number	Cap. (Tons)	Min. Size Runway Beam	Max. Allowable Load on Each Wheel (lbs.)	Net Weight (lbs.)
4210010	2	6"	1200	233

Crane Fabricating and Clearance Dimensions

Capacity (Tons)	Span (Feet)	Recommended Bridge Beams	Y (Inches)
1	10	6" x 12.5#	2
	15	8" x 18.4#	2-1/4
	20	10" x 25.4#	2-3/4
	25	12" x 31.8#	3
2	10	8" x 18.4#	2-1/4
	15	10" x 25.4#	2-3/4
	20	12" x 31.8#	3
	25	15" x 42.9#	3-1/2

Warning: Only competent personnel familiar with standard fabrication practices should be employed to assemble these cranes because of the necessity of properly interpreting these instructions and for the purposes of determining appropriate compatible equipment and product applications. ACCO disclaims and responsibility for the quality of workmanship employed in the fabrication of a crane according to these instructions or the sufficiency of the system in which and to which this system or equipment is to be installed or the sufficiency of the system to sustain any particular load that may be imposed upon it. Contact ACCO for additional information if necessary.

HAND CHAIN HOISTS



ACCOLIFT® portable, lightweight hand chain hoists are compact and provide a dependable working tool for: industrial maintenance, construction sites, machine shops, and production situations where parts need to be positioned accurately but infrequently.

Construction Features:

Hooks: All hooks are drop forged, heat treated steel with spring type latches. Both hooks rotate 360° for easy rigging.

Mechanical Load Brake: Weston type multiple disc brake controls load smoothly, holding full capacity loads in any position.

Overload Clutch: Clutch provided to prevent lifting overloads that could permanently damage hoist. Preset at the factory, the device is installed between the chain wheel and the load brake.

Hand Chain: Electric welded, close link galvanized coil chain, accurately and uniformly sized to seat properly in handwheel pockets.

Load Sheaves: Deep cast pockets precisely fit the load chain. Load shafts are supported by prelubricated bearings for smooth operation.

Load Chain: Electric welded alloy steel chain is heat treated for wear resistance and strength. Accurately and uniformly sized to seat properly in load sheaves.

Frame: Fabricated rolled steel plate.

Covers: Protective steel covers can easily be removed for inspection and maintenance. Covers protect chain wheel, overload clutch, brake and gearing from debris.

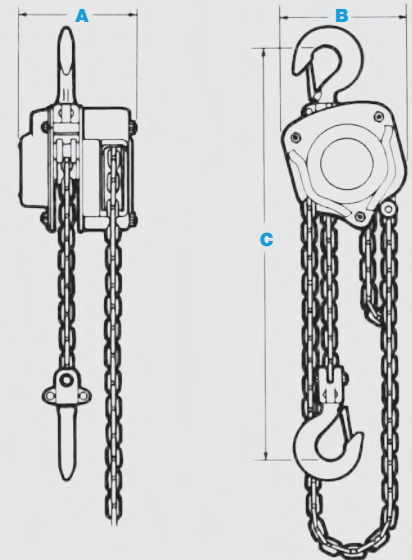

Options: Optional equipment available for this product includes chain container, weather cover, nickel plated load chain, stainless steel load chain, stainless steel hand chain, bronze hooks, stainless steel hooks, nickel plated hoist body and hoists lug mounted to a trolley. Please contact factory for more information.

For hook dimensions and options, see page 26.

Model Number	Cap. (Tons)	Std. Lift (ft.)	Hand Chain Drop (ft.)	Pull to Lift Full Load (lbs.)	Chain Overhaul Ratio	Dimensions (in.)			Load Chain Diameter (in.) X Chain Fall Lines	Weight for Add'l 1ft. of lift (lbs.)	Net Weight (lbs.)
						A	B	C			
1360210	1/2	10	8	53	40:1	5.8	5.7	12.2	.248 x (1)	0.6	25
1360220	1/2	20	18	53	40:1	5.8	5.7	12.2	.248 x (1)	0.6	31
1360230	1	10	8	73	40:1	5.8	5.7	13.0	.248 x (1)	0.6	26
1360240	1	20	18	73	40:1	5.8	5.7	13.0	.248 x (1)	0.6	32
1360250	2	10	8	75	78:1	7.2	7.4	15.0	.311 x (1)	1.0	48
1360260	2	20	18	75	78:1	7.2	7.4	15.0	.311 x (1)	1.0	58
1360270	3	10	8	77	120:1	5.8	8.1	18.9	.280 x (2)	1.5	51
1360280	3	20	18	77	120:1	5.8	8.1	18.9	.280 x (2)	1.5	66
1360290	5	10	8	86	186:1	7.3	10.1	24.4	.354 x (2)	2.4	90
1360300	5	20	18	86	186:1	7.3	10.1	24.4	.354 x (2)	2.4	114
1360310	7 1/2	10	8	88	248:1	7.3	14.4	28.3	.354 x (3)	3.6	116
1360320	7 1/2	20	18	88	248:1	7.3	14.4	28.3	.354 x (3)	3.6	152
1360330	10	10	8	90	372:1	7.3	14.4	32.3	.354 x (4)	4.8	202
1360340	10	20	18	90	372:1	7.3	14.4	32.3	.354 x (4)	4.8	250
1360350	15	10	8	90 X (2)	248:1 (x2)	8.3	29.3	33.5	.354 x (6)	7.2	320
1360360	15	20	18	90 X (2)	248:1 (x2)	8.3	29.3	33.5	.354 x (6)	7.2	392
1360370	20	10	8	90 X (2)	372:1 (x2)	8.3	34.4	38.2	.354 x (8)	9.6	427
1360380	20	20	18	90 X (2)	372:1 (x2)	8.3	34.4	38.2	.354 x (8)	9.6	523

PLAIN TROLLEYS



ACCOLIFT® Plain Trolleys are light and easy to adapt to a wide range of beams. The trolley wheels include lifetime lubricated ball bearings for maintenance free operation. A perfect match to make the ACCOLIFT® electric or hand chain hoist and its load horizontally mobile.

Construction Features:

Side Frame: Side plates are rugged rolled steel

Wheels: Crown tread allows operation on tapered or flat flange beams

Bearings: Shielded, lifetime lubricated, single row ball bearings.

Suspension Lug: Pivot mounted suspension shaft designed to equally distribute the load to all wheels.

Options: Optional equipment available for this product includes bronze wheels and nickel plated body. Please contact the factory for more information.

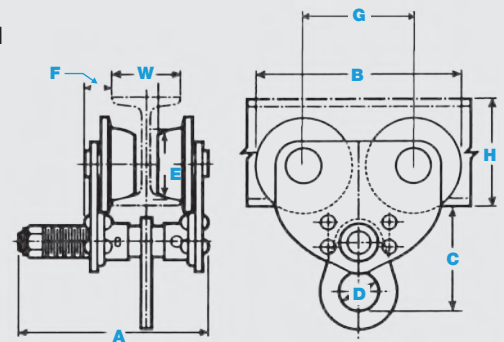

Dimensions in Inches (Nominal)

Model Number	Cap. (Tons)	W Beam Width Min. - Max.	Dimensions							Min. Beam Size H	Min. Beam Radius	Net Weight (lbs.)
			A	B	C	D	E	F	G			
1650010	1/2	3" to 5"	8.1	6.9	5.1	1.8	2.2	1.1	3.5	4	24	14
1650020	1	3" to 5"	8.1	9.1	5.1	1.8	3.2	1.1	4.8	5	30	22
1650030	2	3" to 6"	9.3	10.6	6.1	2.4	3.9	1.4	5.6	6	36	41
1650040	3	3" to 6"	9.9	12.3	7.5	2.6	4.5	1.9	6.4	7	36	63
1650050	5	5" to 7"	11.1	13.9	9.1	3.0	4.9	2.1	7.2	10	48	97

GEARED TROLLEYS



ACCOLIFT® Geared Trolleys are light and easy to adapt to a wide range of beams. The trolley wheels include lifetime lubricated ball bearings for maintenance free operation. A perfect match to make the ACCOLIFT® electric or hand chain hoist and its load horizontally mobile for short distances and accurate load positioning.

Construction Features:

Side Frame: Side plates are rugged rolled steel

Wheels: Crown tread allows operation on tapered or flat flange beams

Bearings: Shielded, lifetime lubricated, single row ball bearings.

Hand Chain: Electric welded, close link galvanized coil chain, accurately and uniformly sized to seat properly in handwheel pockets.

Chain Guide: Steel chain guide.

Suspension Lug: Pivot mounted suspension shaft designed to equally distribute the load to all wheels.

Options: Optional equipment available for this product includes bronze wheels, stainless steel hand chain and nickel plated body. Please contact the factory for more information.

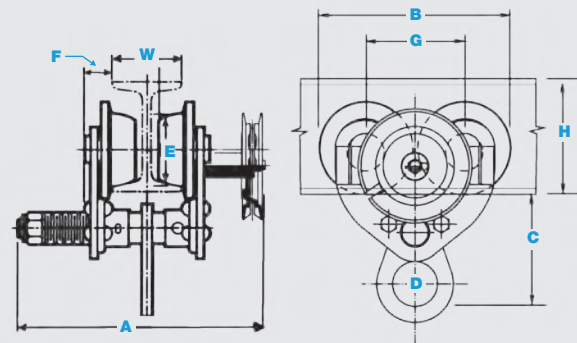

Dimensions in Inches (Nominal)

Model Number	Cap. (Tons)	W Beam Width Min. - Max.	Hand Chain Drop (ft.)	Dimensions							Min. Beam Size H	Min. Beam Radius	Net Weight (lbs.)
				A	B	C	D	E	F	G			
1650110	1/2	3" to 5"	18	10.8	9.1	5.1	1.8	3.2	1.1	4.8	5	30	35
1650120	1	3" to 5"	18	10.8	9.1	5.1	1.8	3.2	1.1	4.8	5	30	35
1650130	2	3" to 6"	18	12.0	10.6	6.1	2.4	3.9	1.4	5.6	6	36	57
1650140	3	3" to 6"	18	13.0	12.3	7.5	2.6	4.5	1.9	6.4	7	36	79
1650150	5	5" to 7"	18	15.0	13.9	9.1	3.0	4.9	2.1	7.2	10	48	114
1650160	10	5" to 7.5"	18	17.0	13.9	11.0	3.2	4.9	2.1	7.2	10	48	227

MOTORIZED TROLLEYS



Accolift Motorized Trolleys are rugged in design and built to be flexible right out of the box. Each trolley is adjustable for a beam flange range of 3.25" to 12" with no additional materials required. Side guide rollers are included to promote smooth trolley motion and to minimize wheel and beam flange wear. Wheels are dual tread design for operation on tapered or flat flange beams. Trolleys include drop down lugs and rubber bumpers as standard equipment. Motor includes class F insulation and a disc type motor brake. Motor is rated for 30-minute duty and includes standard thermal protection. Three phase trolleys include a VFD control, 2-button pendant, control transformer and a 30' power cord. Single phase trolleys include a single speed contactor control, 2-button pendant and a 30' power cord.

Construction Features:

- Motor:** 30-min duty motor with class F insulation, thermal protection and motor brake.
- Three Phase Control:** VFD control programmed for two speed operation.
- Single Phase Control:** Contactor control provided for single speed operation.
- Side Frame:** Side plates are rugged rolled steel.
- Wheels:** Dual tread design for operation on tapered or flat flange beams.
- Bearings:** Shielded, lifetime lubricated, single row ball bearings.
- Suspension Lug:** Pivot mounted suspension lug provides equally distributed load to all wheels.

Cap. (Tons)	Model Number	Trolley Speed (fpm)	Push Button Cord Length (ft.)	Power Cord Length (ft.)	Motor				Flange Width Adjustability (in.)	Wheel Diameter	Min. Beam Radius (in.)	Net Wt. (lbs.)
					HP	Amp. Draw						
						115V	208/230V	460V				
1	2130510-VFD	75/25	6	30	0.54	-	3.3/3.0	1.5	3.25 to 12	3.7	32	86
2	2130520-VFD	75/25	6	30	0.54	-	3.3/3.0	1.5	3.25 to 12	4.3	32	101
3	2130530-VFD	65/22	6	30	1	-	4.8/4.4	2.2	3.25 to 12	5	40	165
5	2130550-VFD	65/22	6	30	1	-	4.8/4.4	2.2	3.25 to 12	5.5	72	210

SINGLE PHASE TROLLEYS:

1	2330510	36	6	30	0.27	7.8	4.3/3.9	-	3.25 to 12	3.7	32	86
2	2330520	36	6	30	0.27	7.8	4.3/3.9	-	3.25 to 12	4.3	32	101

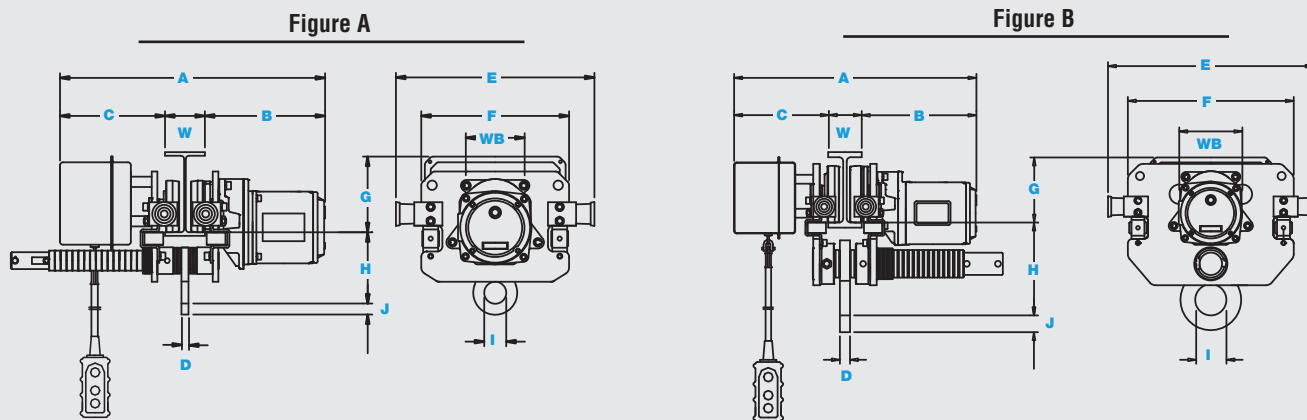

Dimensions in Inches (Nominal).

Model Number	A W = Beam width	B	C	D	E	F	G	H	I Diameter	J	WB	Figure
2130510-VFD	18.7 + W	10	8.7	0.5	16	11.8	6.5	5.2	1.8	0.8	4.4	A
2130520-VFD	18.9 + W	10.1	8.8	0.6	16.7	12.4	6.4	6	1.8	0.9	4.9	A
2130530-VFD	19.8 + W	10.9	8.9	0.8	18	14.2	6.2	7.2	2.6	1.3	5.5	B
2130550-VFD	20.4 + W	11.2	9.2	1	20	16.1	6.3	9	3	1.4	6.1	B
2330510	18.7 + W	10	8.7	0.5	16	11.8	6.5	5.2	1.8	0.8	4.4	A
2330520	18.9 + W	10.1	8.8	0.6	16.7	12.4	6.4	6	1.8	0.9	4.9	A

LEVER HOISTS

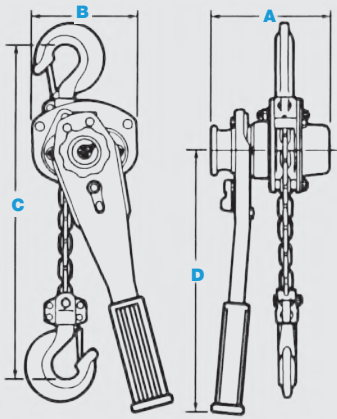

Lightweight, portable, chain type lever operated puller. Increases a worker's efficiency in pulling, lifting, lowering, moving and skidding objects in industrial maintenance, construction and utility company applications. Minimal effort is required to move tons. The short handle and short stroke are designed to operate in tight places. Excellent for stretching cable and fencing, positioning machinery and building components.

Construction Features:

Frame/Side Plate: Rugged, lightweight steel design supports and protects internal gearing. Frame designed to allow load hook to be attached when operator is moving from location to location preventing dragging of the load hook.

Load Lever: Designed and constructed to be easily operated by one person. Can be easily disassembled for maintenance.

Operation: The length of the load chain can easily be adjusted using the free chaining device. This device allows free movement of the load chain through the hoist under no load conditions. Once the chain is attached to the load and the slack is taken out, the change lever can be set to "up" to engage the hoist and chain will be pulled through the device with each stroke of the lever by the operator. When the operator needs to move the lever hoist to the next required location, the bottom hook assembly can be attached to the hoist body preventing dragging the hook through debris.

Gears: Gearing is cold forged and permanently lubricated for longevity. Gear case cover includes bushings to support pinion shaft and change gears.

Mechanical Load Brake: Weston type multiple disc brake controls load smoothly, holding full capacity loads in any position. Load is not transferred back to handle during handle advancement.

Load Chain: Electric welded alloy steel chain is heat treated for strength and wear resistance. Accurately and uniformly sized to seat properly in the deep pockets of the load sheaves.

Load Block: The load block supports the load hook permitting hook to swivel 360° under capacity loads. Load block is designed to guide the chain without jamming during normal operation.

Hooks: All hooks are drop forged, heat treated steel with spring type latches. Both hooks rotate 360° for easy rigging.

Options: Overload clutch, nickel plated load chain and shipyard hooks.

For hook dimensions, see page 26.

Model Number	Model Number with Overload	Cap. (Tons)	Std. Lift (ft.)	Pull to Lift Full Load (lbs.)	Dimensions (in.)				Load Chain Diameter (in.) X Chain Fall Lines	Weight for Add'l 1ft. of lift (lbs.)	Net Weight (lbs.)
					A	B	C	D			
1150410	1150410-OL	3/4	5	66 lb	6.1	4.8	13.0	10.8	.248 x (1)	14	0.6
1150420	1150420-OL	3/4	10	66 lb	6.1	4.8	13.0	10.8	.248 x (1)	14	0.6
1150430	1150430-OL	1 1/2	5	66 lb	6.6	5.6	14.9	15.2	.280 x (1)	21	0.8
1150440	1150440-OL	1 1/2	10	66 lb	6.6	5.6	14.9	15.2	.280 x (1)	21	0.8
1150450	1150450-OL	2	5	88 lb	6.6	5.6	15.5	15.2	.280 x (1)	24	1
1150460	1150460-OL	2	10	88 lb	6.6	5.6	15.5	15.2	.280 x (1)	24	1
1150470	1150470-OL	3	5	81 lb	7.9	6.8	18.3	15.2	.354 x (1)	35	1.2
1150480	1150480-OL	3	10	81 lb	7.9	6.8	18.3	15.2	.354 x (1)	35	1.2
1150490	1150490-OL	6	5	84 lb	7.9	9.5	13.7	15.2	.354 x (2)	59	2.4
1150500	1150500-OL	6	10	84 lb	7.9	9.5	13.7	15.2	.354 x (2)	59	2.4
1150510	1150510-OL	9	5	86 lb	7.9	13.7	30.5	15.2	.354 x (3)	90	3.6
1150520	1150520-OL	9	10	86 lb	7.9	13.7	30.5	15.2	.354 x (3)	90	3.6

HOOK DIMENSIONS

HAND CHAIN HOISTS - HOOK DIMENSIONS:

Capacity (Ton)	A	B	C	D	E
1/2	0.63	2.87	0.79	1.42	1.08
1	0.79	3.39	0.94	1.57	1.12
2	0.94	4.45	1.18	1.97	1.38
3	1.10	5.24	1.65	2.13	1.61
5	1.42	5.98	1.81	2.40	1.73
7 1/2	1.65	7.28	2.60	2.80	1.69
10	2.44	9.29	3.54	3.15	2.03
15	2.56	10.63	3.54	4.33	2.36
20	3.11	12.72	4.65	4.72	3.35

LEVER HOISTS - HOOK DIMENSIONS:

Capacity (Ton)	A	B	C	D	E
3/4	0.61	2.91	0.74	1.42	0.91
1 1/2	0.85	4.04	1.12	1.69	1.10
2	0.94	4.44	1.24	1.85	1.10
3	1.26	4.94	1.37	2.09	1.34
6	1.46	5.98	1.77	2.44	1.81
9	2.13	9.31	3.31	3.54	2.20

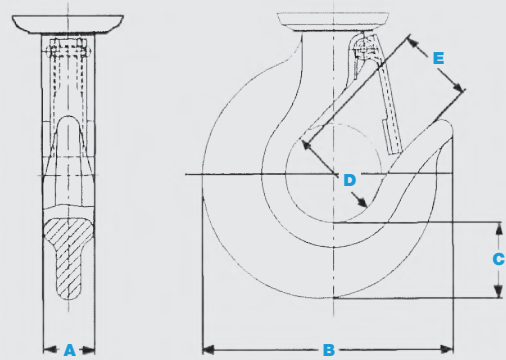

OPTIONS FOR HAND CHAIN HOISTS

Bronze wheels, nickel plated trolley and hoist body, nickel plated hand and load chain, bronze coated hook and load block.



Bronze wheels, bronze load hook and stainless steel load chain.

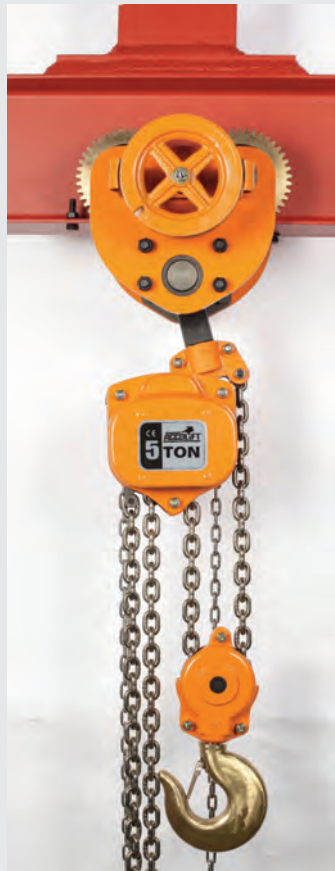

Stainless steel load chain, bottom block and hook.



Chain container.



Call your Acco Material Handling sales professional today and put the reliability of Accolift equipment to work at your facility.

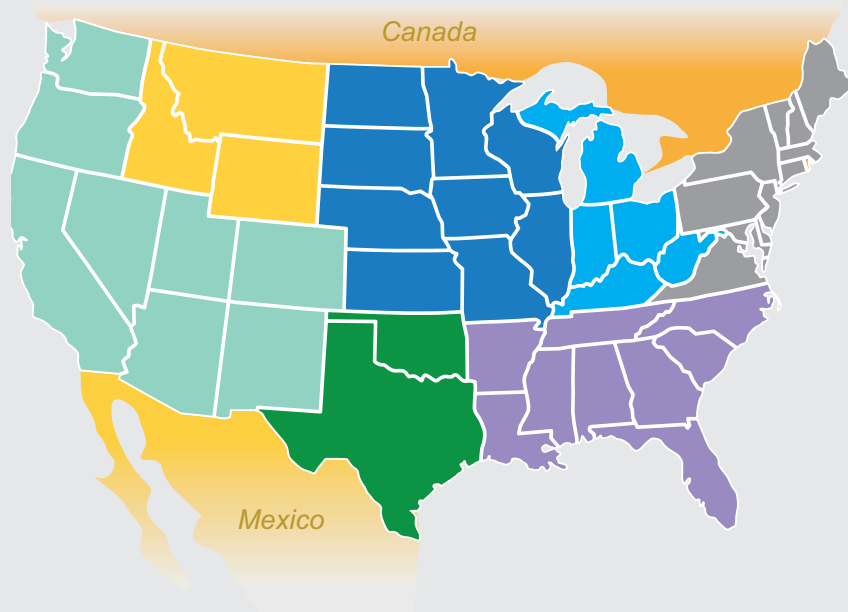

Robert Webb, Sales Representative
 Robert@rgwsalescanada.com
 289-339-3644
 Canada, All Provinces

Jim Orme, District Manager
 jorme@accomhs.com
 717-676-1351
 North Dakota, South Dakota, Nebraska, Iowa, Missouri, Illinois, Minnesota, Wisconsin, Kansas

Jeff Dawson, Director of Sales
 jdawson@accomhs.com
 717-676-1347
 Montana, Idaho, Wyoming, Mexico

Bill Burke, District Manager
 bburke@accomhs.com
 717-676-8889
 Pennsylvania, Virginia, New York, New Jersey, Maryland, Vermont, New Hampshire, Maine, Connecticut, Delaware, D.C., Massachusetts, Rhode Island

Alan Hopes, District Manager
 ahopes@accomhs.com
 717-825-7745
 Michigan, Indiana, Kentucky, Ohio, West Virginia

Greg Logan, District Manager
 glogan@accomhs.com
 717-676-1345
 Arkansas, Mississippi, Tennessee, Louisiana, North Carolina, South Carolina, Georgia, Alabama, Florida

Nina Peterson, District Manager
 npeterson@accomhs.com
 717-654-2896
 Texas, Oklahoma

Keith McColm, District Manager
 kmccolm@accomhs.com
 717-676-1348
 Arizona, California, Nevada, Utah, Oregon, Washington, Colorado, New Mexico, Hawaii, Alaska

Learn more at:
www.AccoMHS.com

Ask about these top brand name products from ACCO Material Handling Solutions:

WRIGHT®

Wire rope hoists and crane components manufactured in capacities from 1 to 25 tons.

LOUDEN® TRAMBEAM®

Patented Track Cranes and Monorail Systems.

MANSAVER® VAC-U-LIFT®

Below-the-hook lifters; both standard and custom engineered.

Nutting®

Industrial trailers and non-powered material handling equipment of all types.

WARNING: Equipment described herein is not designed for, and should not be used for lifting, supporting, or transporting humans. Modifications to upgrade, rerate, or otherwise alter the hoist or crane equipment shall be authorized only by the original manufacturer or qualified professional engineer. Failure to comply with any one of the limitations noted herein may result in serious bodily injury.

WARRANTY: All equipment is covered by the following warranties: The Seller warrants to the original using Buyer thereof that the goods sold under this agreement are free from defects in workmanship and materials for a period of one year from the date of shipment to the using Buyer. No other express warranties are given and no affirmation of Seller or Seller's agents, by word or action, shall constitute a warranty. Any variations in details between the goods quoted herein and those covered in Buyer's specifications are due to standards of manufacture not to be construed as exceptions to the specifications.



Work-Rated Class 1, Groups C & D, Division 1 hoist monorail hoist.



Louden crane with Speedway hoists.



Industrial Trailer suitable for warehousing and/or manufacturing applications.



ACCO Material Handling Solutions
76 Acco Drive, Box 792, York, PA 17405-0792
717-741-4863, 800-967-7333, FAX 800-715-8897
E-mail: info@accomhs.com
www.accomhs.com