

Acco[®] LOUDEN[®]

underhung cranes
product series 500

installation
operation
maintenance
and parts
manual

SERIAL NUMBER

⚠ WARNING

This equipment should not be installed, operated or maintained by any person who has not read all the contents of these instructions. Failure to read and comply with the instructions or any one of the limitations noted herein can result in serious bodily injury or death, and/or property damage.

There are no other warranties which extend beyond the description on the Order Acknowledgment and as it may apply to the specifications provided in this publication. **THE IMPLIED WARRANTIES OF MERCHANTABILITY AND FITNESS FOR A PARTICULAR PURPOSE ARE EXCLUDED.** Acco shall in no event be liable for any special, direct, indirect, incidental or consequential damages to anyone beyond the cost of replacement of the goods sold hereby.

TABLE OF CONTENTS

NOTICE

Manual 69878 covers information in reference to standard models of the LOUDEN® Series 500 Underhung Cranes. This manual includes instructions and parts information for a variety of crane types. Therefore, all instructions or parts information may not apply to any one type or size of specific crane. Disregard those portions of the manual that do not apply. Manual 69878 should be used in conjunction with Manual 69879: Installation, Operation, Maintenance, and Parts Manual for LOUDEN® Underhung Crane and Monorail Accessories; and with Manual 69880: Installation, Operation, Maintenance, and Parts Manual for LOUDEN® Monorail Track and Fittings. Use of the term MANUAL refers to all of these manuals as applicable. MANUALS FOR SPECIAL ENGINEERED CRANES AND MONORAILS WILL CONTAIN ADDITIONAL PAGES IN ACCORDANCE WITH PRODUCT SPECIFICATIONS.

<u>SUBJECT</u>	<u>PAGE</u>
IMPORTANT INFORMATION AND WARNINGS	3
CRANE TYPES	5
INSTALLATION	10
OPERATION	19
MOTOR OVERLOAD FEATURES	23
MAINTENANCE AND INSPECTION PROCEDURES	24
INSPECTION	25
TEST	29
MAINTENANCE AND REPAIR	33
LUBRICATION	34
CRANE DRIVE BRAKE	39
END TRUCKS AND WHEELS	42
ELECTRICAL COMPONENTS	43
ACCELERATION CONTROL MODULE V	48
TROUBLESHOOTING	50
TYPICAL BRIDGE INTERCONNECTION DIAGRAM	52
TYPICAL WIRING DIAGRAM	54
CRANE DRIVE MOTOR BRAKE ASSEMBLY	58
CRANE DRIVE MOTOR	59
STEEL WHEEL DRIVE ASSEMBLY	60
3A107 DRIVE UNIT ASSEMBLY – 2 HP MAX	62
3A107 DRIVE UNIT ASSEMBLY – 3 AND 5 HP	63
9 INCH DRIVE TIRE ASSEMBLY	64
SUPERTRACK™ END TRUCK ASSEMBLIES	65
TROJANTRACK™ END TRUCK ASSEMBLIES	72
SUPERTRACK™ TROLLEYS	74
TROJANTRACK™ TROLLEYS	81
BASIC CONTROL COMPONENTS	84
PENDANT CONTROL STATION	88

NOTICE

TO ORDER PARTS: Provide part number, part description, quantity required, and Product Number or Serial Number of Crane.

IMPORTANT INFORMATION AND WARNINGS

SAFETY ALERT SYMBOL

The Safety Alert Symbol is used in this manual to indicate hazards and to alert the reader to information that should be known, understood, and followed in order to avoid DEATH or SERIOUS INJURY.

Read and understand this manual before using the crane.

Important issues to remember during operation are provided at the crane control stations, at various locations on the crane and in the manuals by **DANGER**, **WARNING**, or **CAUTION** instructions or placards, that alert the personnel to potential hazards, proper operation, load limitations, and more.

DANGER

Indicates an imminently hazardous situation which, if not avoided, will result in death or serious injury.

WARNING

Indicates a potentially hazardous situation which, if not avoided, could result in death or serious injury.

CAUTION

Indicates a potentially hazardous situation which, if not avoided, may result in minor or moderate injury. It may also be used to alert against unsafe practices.

CAUTION

These general instructions deal with the normal installation, operation, inspection, and maintenance situations encountered with the equipment described herein. The instructions should not be interpreted to anticipate every possible contingency or to anticipate the final system, crane, or configuration that uses this equipment.

This manual includes instructions and parts information for a variety of crane or monorail types. Therefore, all instructions and parts information may not apply to any one type or size of specific crane or monorail. Disregard those portions of the instructions that do not apply.

Record crane or monorail serial number on the front cover of this manual for identification and future reference to avoid referring to the wrong manual for information or instructions on installation, operation, inspection, maintenance, or parts.

Use only LOUDEN® authorized replacement parts in the service and maintenance of this equipment.

WARNING

Equipment described herein is not designed for and should not be used for lifting, supporting, or transporting humans.

Equipment described herein should not be used in conjunction with other equipment unless necessary and/or required safety devices applicable to the system, crane, or application are installed by the system designer, system manufacturer, crane manufacturer, installer, or user.

Modifications to upgrade, rerate, or otherwise alter this equipment shall be authorized only by the original equipment manufacturer or qualified professional engineer.

Equipment described herein may be used in the design and manufacture of cranes or monorail systems. Additional equipment or devices may be required for the crane or monorail system to comply with applicable crane or monorail design and safety standards. The crane or system designer, crane or system manufacturer, or user is responsible to furnish these additional items for compliance. Refer to ASME B30.11, Safety Standard for Monorails and Underhung Cranes. If a hoist is used with this equipment, refer to ASME B30.16, Safety Standard for Overhead Hoists. If a below-the-hook lifting device or sling is used with this equipment, refer to ASME B30.9, Safety Standard for Slings, or ASME B30.20, Safety Standard for Below-the-Hook Lifting Devices.

Hoists, cranes, and monorails used to handle hot molten material may require additional equipment or devices. Refer to ANSI Z241.2, Safety Requirements for Melting and Pouring of Metals in the Metalcasting Industry.

Electrical equipment described herein is designed and built in compliance with ACCO Chain & Lifting Products interpretation of ANSI/NFPA 70, National Electrical Code. The system designer, system manufacturer, crane designer, crane manufacturer, installer, or user is responsible to assure that all installation and associated wiring of these electrical components is in compliance with ANSI/NFPA 70, and all applicable Federal, State, and Local Codes.

Failure to read and comply with any of the limitations noted herein can result in serious bodily injury or death, and/or property damage.

IMPORTANT INFORMATION AND WARNINGS

DANGER

HAZARDOUS VOLTAGES ARE PRESENT IN THE CONTROL ENCLOSURE, OTHER ELECTRICAL COMPONENTS, AND CONNECTIONS BETWEEN THESE COMPONENTS.

Before performing ANY mechanical or electrical maintenance on the equipment, de-energize (disconnect) the main switch supplying power to the equipment; and lock and tag the main switch in the de-energized position. Refer to ANSI Z244.1, Personnel Protection — Lockout/Tagout of Energy Sources.

Do not operate the equipment without control enclosure cover or covers in place.

Only trained and competent personnel should inspect and repair this equipment.

NOTICE

It is the responsibility of the owner/user to install, inspect, test, maintain, and operate a crane or monorail in accordance with ASME B30.11, Safety Standard for Monorails and Underhung Cranes, OSHA Regulations, and ANSI/NFPA70, National Electrical Code. If the crane or monorail is installed as part of a total lifting system, it is also the responsibility of the owner/user to comply with the applicable ASME B30 volume that addresses other types of equipment used in the system.

It is the responsibility of the owner/user to have all personnel that will install, inspect, test, maintain, and operate a crane or monorail read the contents of this manual and applicable portions of ASME B30.11, Safety Standard for Monorails and Underhung Cranes, OSHA Regulations, and ANSI/NFPA70, National Electrical Code. If the crane or monorail is installed as part of a total lifting system, the applicable ASME B30 volume that addresses other types of equipment used in the system must also be read by all personnel.

Any ANSI Standards referenced in this manual may be obtained from the American National Standards Institute, 1430 Broadway, New York, New York 10018.

This manual contains information for safe operation of an underhung crane or monorail. Taking precedence over any specific rule, however, is the most important rule of all — "USE COMMON SENSE". Operation of an underhung crane or monorail involves more than operating the controls. The operator must consider and anticipate the motions and actions that will occur as a result of operating the controls.

If the crane or monorail owner/user requires additional information, or if any information in the manual is not clear, contact ACCO Chain & Lifting Products, York, Pennsylvania or the distributor of the crane or monorail. Do not install, inspect, test, maintain, or operate this equipment unless this information is fully understood.

When contacting ACCO Chain & Lifting Products or the distributor of the crane or monorail, always make reference to the serial number of the equipment.

A regular schedule of inspection of the crane and monorail in accordance with the requirements of ASME B30.11 should be established and records maintained.

WARNING

Before installing, removing, inspecting, or performing any maintenance on a hoist, crane, or monorail; the main switch shall be de-energized. Lock and tag the main switch in the de-energized position in accordance with ANSI Z244.1. Follow other maintenance procedures outlined in this manual and applicable ASME B30 volumes.

Additional WARNINGS are listed in various portions of this manual. Personnel shall read and follow these WARNINGS. Failure to read and comply with these WARNINGS as well as other instructions or any limitations noted in this manual and applicable ASME B30 volumes could result in serious bodily injury or death, and/or property damage.

WARNING

IF LOUDEN® CRANES ARE INSTALLED TO OPERATE ON RUNWAYS THAT ARE COMPRISED OF TRACK OTHER THAN LOUDEN® MONORAIL TRACK; OR IF LOUDEN® MONORAIL TRACK IS USED FOR OPERATION OF CRANES OR CARRIERS NOT MANUFACTURED BY LOUDEN®; THE SYSTEM DESIGNER, SYSTEM MANUFACTURER, OR SYSTEM INSTALLER IS RESPONSIBLE TO DETERMINE THE COMPATIBILITY OF THE CRANE AND MONORAIL TRACK; AND THAT THE LOAD RATINGS OF NEITHER THE CRANE OR MONORAIL TRACK WILL BE EXCEEDED.

CRANE TYPES

LOUDEN® cranes are available in a variety of configurations. In addition to capacity and span variations, LOUDEN® cranes are available in hand propelled or motor driven types; single girder or double girder types; and drive tire or steel-wheel driven types. The type or series of LOUDEN® crane specified must be capable of operating on the type of LOUDEN® runway track being installed or already existing. Types of LOUDEN® track are 602 *SuperTrack™*, 603 *SuperTrack™*, 604 *SuperTrack™ Girder*, 605 *TrojanTrack™ Girder*, and *Super-TrojanTrack™ Girder*.

General descriptions of different LOUDEN® crane series are presented below for information purposes, and to serve as a guide to aid in using the instructions and parts information outlined in this manual. Standard cranes normally operate on two runways. Cranes can also be of multiple end truck configuration for operation on three or more runways. Detailed specifications can be obtained from catalog data or order specifications. If additional information is required, contact Acco Chain & Lifting Products or the distributor of the crane.

LOUDEN® SERIES 503 CRANE:

The LOUDEN® Series 503 crane is a single girder, motor driven crane with center drive and adjustable spring-loaded drive tires. Standard models are available in capacities of 1 through 5 tons, with spans to 58 feet. The Series 503 crane will operate on runways of 603 *SuperTrack™*, 604 *SuperTrack™ Girder*, or 605 *TrojanTrack™ Girder*, having a 3.33 inch operating flange. End trucks are either 4-wheel or 8-wheel trucks, with 4½ inch diameter wheels. Refer to Figure 1.

LOUDEN® SERIES 503T CRANE:

The LOUDEN® Series 503T crane is a single girder, motor driven crane with center drive and adjustable spring-loaded drive tires. Standard models are available in capacities of 5 through 10 tons, with spans to 60 feet. The Series 503T crane will operate on runways of 605 *TrojanTrack™ Girder* or *Super-TrojanTrack™ Girder*, having a 3.33 inch operating flange. End trucks are 8-wheel trucks, with 9 inch diameter wheels. Refer to Figure 1.

FIGURE 1

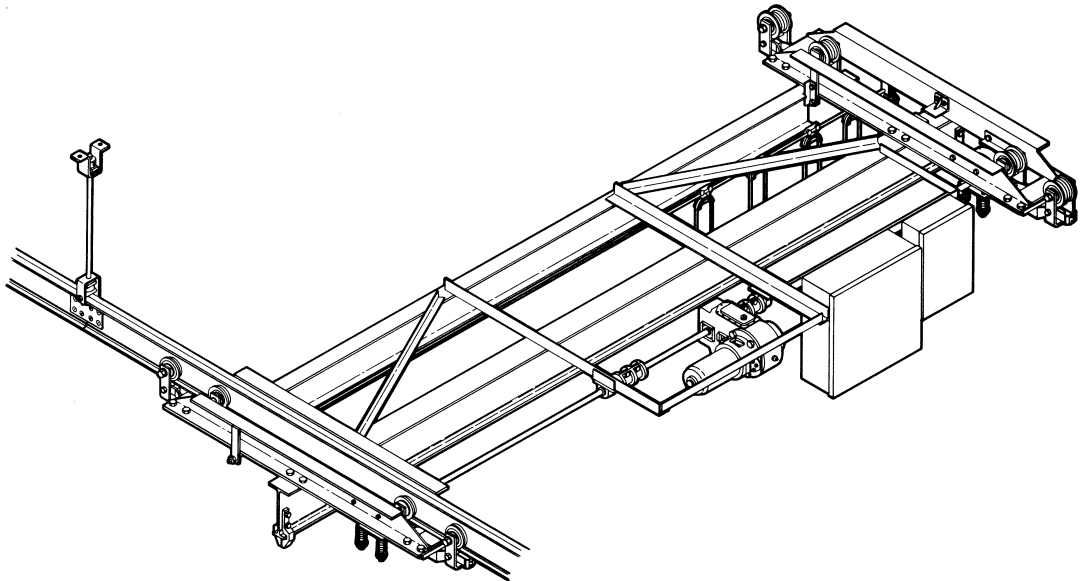

LOUDEN® SERIES 510 CRANE:

The LOUDEN® Series 510 crane is a single girder truss type, motor driven crane with center drive and adjustable spring-loaded drive tires. Standard models are available in capacities of 3 through 10 tons, with spans to 100 feet. The Series 510 crane will operate on runways of 603 *SuperTrack™*, 604 *SuperTrack™ Girder*, or 605 *TrojanTrack™ Girder*, having a 3.33 inch operating flange. End trucks are either 8-wheel or 16-wheel trucks, with 4½ inch diameter wheels. Refer to Figure 2.

CRANE TYPES

LOUDEN® SERIES 510T CRANE:

The LOUDEN® Series 510T crane is a single girder truss type, motor driven crane with center drive and adjustable spring-loaded drive tires. Standard models are available in capacities of 5 through 15 tons, with spans to 100 feet. The Series 510T crane will operate on runways of 605 *TrojanTrack™ Girder* or *Super-TrojanTrack™ Girder*, having a 3.33 inch operating flange. End trucks are either 8-wheel or 16-wheel trucks, with 9 inch diameter wheels. Refer to Figure 2.

FIGURE 2

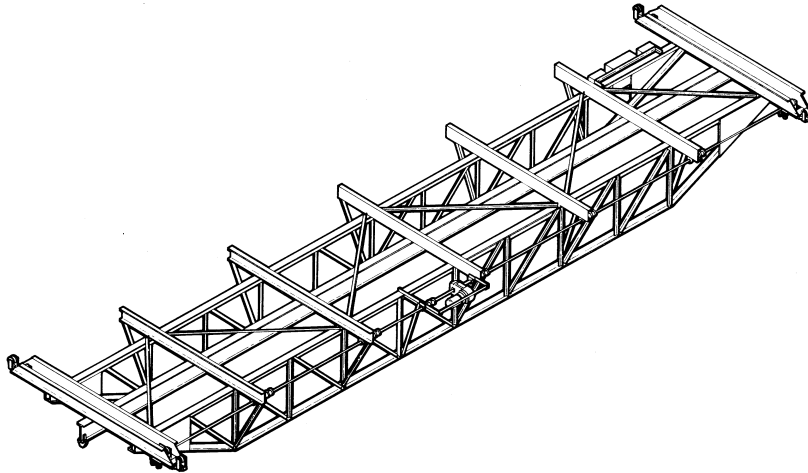

LOUDEN® SERIES 517 CRANE:

The LOUDEN® Series 517 crane is a double girder, motor driven crane with center drive and adjustable spring-loaded drive tires. Standard models are available in capacities of 1 through 10 tons, with spans to 60 feet. The Series 517 crane will operate on runways of 603 *SuperTrack™*, 604 *SuperTrack™ Girder*, or 605 *TrojanTrack™ Girder*, having a 3.33 inch operating flange. End trucks are either 4-wheel, 8-wheel, or 16-wheel trucks, with 4½ inch diameter wheels. Refer to Figure 3.

LOUDEN® SERIES 517T CRANE:

The LOUDEN® Series 517T crane is a double girder, motor driven crane with center drive and adjustable spring-loaded drive tires. Standard models are available in capacities of 5 through 15 tons, with spans to 60 feet. The Series 517T crane will operate on runways of 605 *TrojanTrack™ Girder* or *Super-TrojanTrack™ Girder*, having a 3.33 inch operating flange. End trucks are 8-wheel or 16-wheel trucks, with 9 inch diameter wheels. Refer to Figure 3.

FIGURE 3

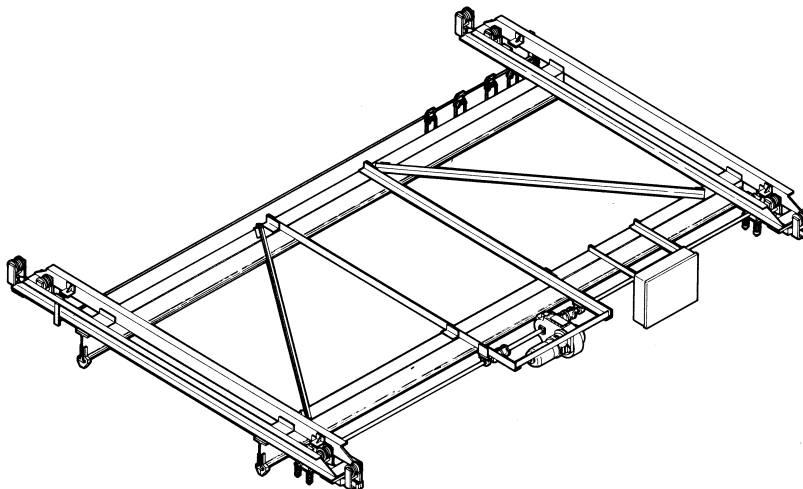

CRANE TYPES

LOUDEN® SERIES 518 CRANE:

The LOUDEN® Series 518 crane is a double girder truss type, motor driven crane with center drive and adjustable spring-loaded drive tires. Series 518 cranes are designed in accordance with specification requirements. The Series 518 crane will operate on runways of 603 *SuperTrack™*, 604 *SuperTrack™ Girder* or 605 *TrojanTrack™ Girder*, having a 3.33 inch operating flange.

LOUDEN® SERIES 518T CRANE:

The LOUDEN® Series 518T crane is a double girder truss type, motor driven crane with center drive and adjustable spring-loaded drive tires. Series 518T cranes are designed in accordance with specification requirements. The Series 518T crane will operate on runways of 605 *TrojanTrack™ Girder* or *Super-TrojanTrack™ Girder*, having a 3.33 inch operating flange.

LOUDEN® SERIES 539 CRANE:

The LOUDEN® Series 539 crane is a single girder, motor driven crane with center drive and adjustable spring-loaded drive tires. Standard models are available in capacities of 1 through 5 tons, with spans to 40 feet. The Series 539 crane will operate on runways of 603 *SuperTrack™*, 604 *SuperTrack™ Girder*, or 605 *TrojanTrack™ Girder*, having a 3.33 inch operating flange. End trucks are either 4-wheel or 8-wheel trucks, with 4½ inch diameter wheels. Refer to Figure 4.

FIGURE 4

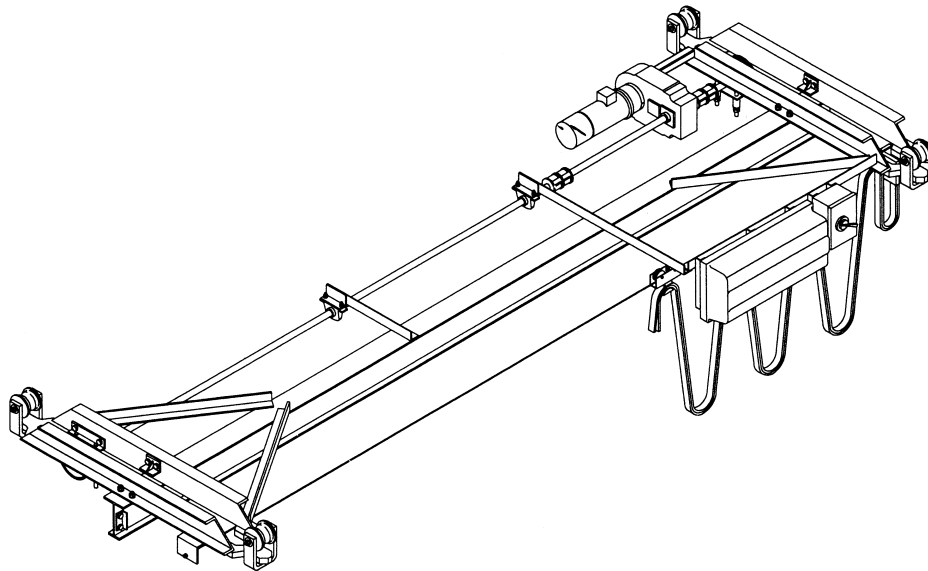

LOUDEN® SERIES 551 CRANE:

The LOUDEN® Series 551 crane is a single girder, hand propelled crane. Standard models are available in capacities of ½ through 1 ton, with spans to 18 feet. The Series 551 crane will operate on runways of 602 *SuperTrack™* having a 2.0 inch operating flange, or 603 *SuperTrack™* or 604 *SuperTrack™ Girder*, having a 3.33 inch operating flange. End trucks are 4-wheel trucks, with 4 inch diameter wheels. Refer to Figure 5.

CRANE TYPES

LOUDEN® SERIES 552 CRANE:

The LOUDEN® Series 552 crane is a single girder, hand propelled crane. Standard models are available in capacities of ½ through 1½ tons, with spans to 50 feet, to operate on runways of 602 *SuperTrack™* having a 2.0 inch operating flange. Standard models are available in capacities of ½ through 3 tons, with spans to 50 feet, to operate on runways of 603 *SuperTrack™* or 604 *SuperTrack™ Girder* having a 3.33 inch operating flange. End trucks are either 4-wheel or 8-wheel trucks, with either 4 inch or 4½ inch diameter wheels. Refer to Figure 5.

FIGURE 5

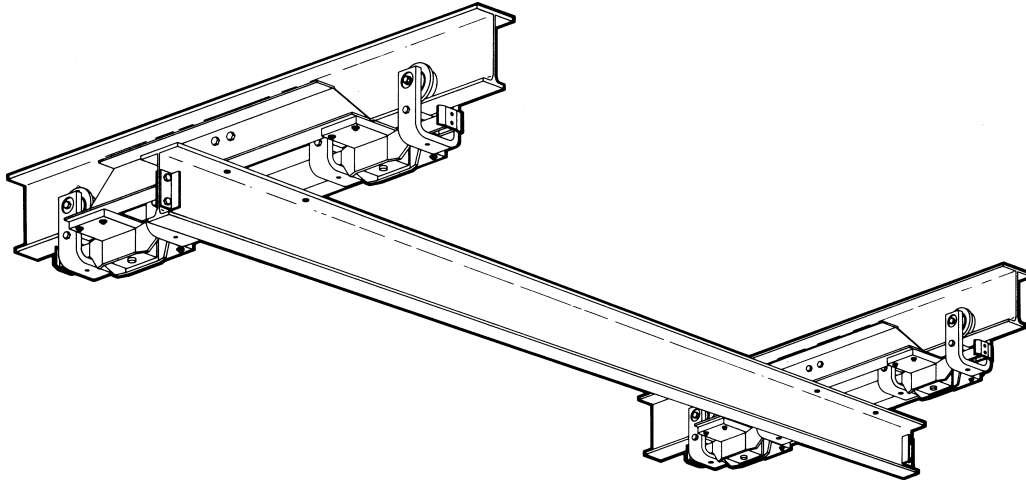

LOUDEN® SERIES 585 CRANE:

The LOUDEN® Series 585 is a single girder, motor driven crane with dual steel-wheel drives. Standard models are available in capacities of 1 through 5 tons, with spans to 58 feet. The Series 585 crane will operate on runways of 603 *SuperTrack™*, 604 *SuperTrack™ Girder*, or 605 *TrojanTrack™ Girder*, having a 3.33 inch operating flange. End trucks are either 4-wheel or 8-wheel trucks, with 4½ inch diameter wheels. Refer to Figure 6.

FIGURE 6

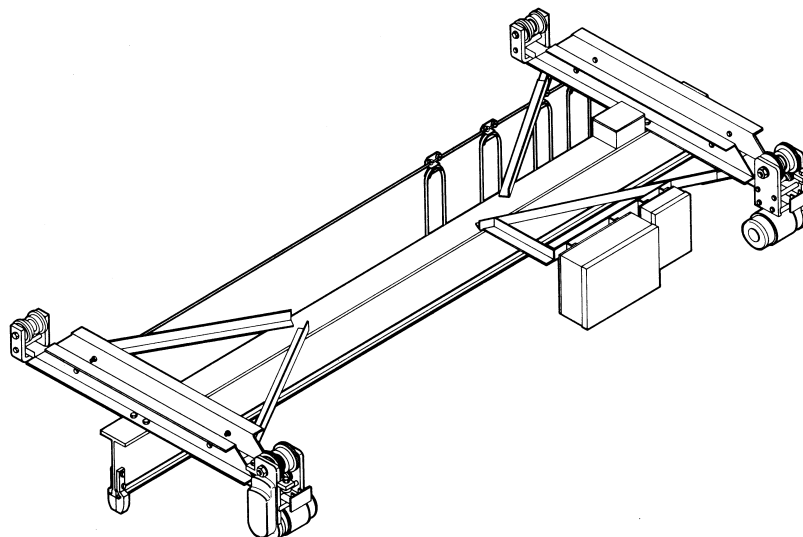

CRANE TYPES

LOUDEN® SERIES 586 CRANE:

The LOUDEN® Series 586 crane is a double girder, motor driven crane with multiple steel-wheel drives. Standard models are available in capacities of 1 through 10 tons, with spans to 56 feet. The Series 586 crane will operate on runways of 603 *SuperTrack™*, 604 *SuperTrack™ Girder*, or 605 *TrojanTrack™ Girder*, having a 3.33 inch operating flange. End trucks are either 4-wheel, 8-wheel, or 16-wheel trucks, with 4½ inch diameter wheels. Refer to Figure 7.

FIGURE 7

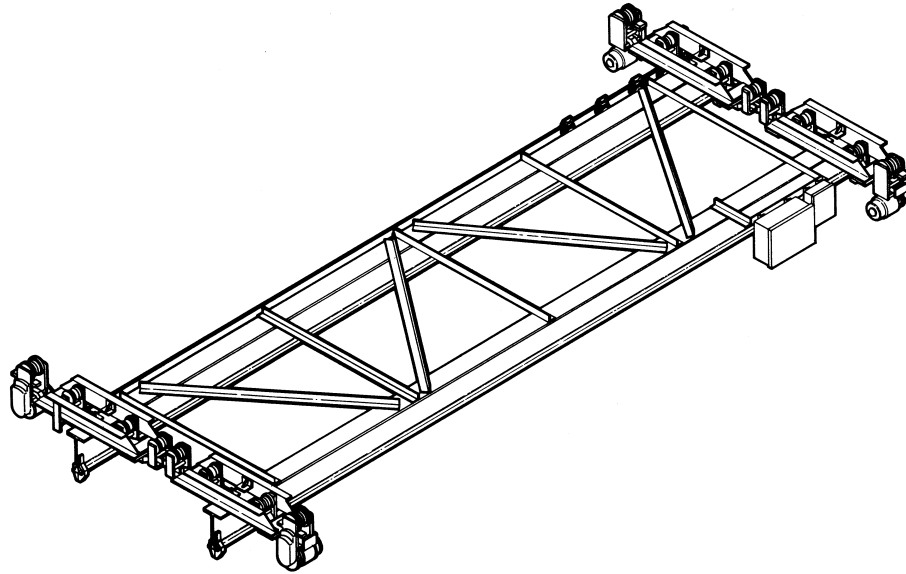

INSTALLATION

PRIOR TO INSTALLING CRANE:

1. Read and observe the instructions and warnings contained in this manual. Read and observe any instructions and warning tags attached to the crane.
2. Read and observe the applicable instructions and warnings contained in Manual 69879, Installation, Operation, Maintenance, and Parts Manual for LOUDEN® Underhung Crane and Monorail Accessories.
3. If LOUDEN® monorail track is being installed as part of the total installation, read and observe the instructions and warnings contained in Manual 69880, Installation, Operation, Maintenance, and Parts Manual for LOUDEN® Monorail Track and Fittings.
4. If a hoist is to be installed on the crane as part of the total installation, read and observe the instructions and warnings contained in the manual furnished with the hoist. Read and observe any instructions and warning tags attached to the hoist.
5. Check for any damage to the crane during shipment. If any damage has occurred, place a claim with the carrier. DO NOT install a damaged crane.
6. Locate any vent plugs attached to or included with the crane drives. Remove solid shipping plug or plugs and replace with a vent plug. Refer to the LUBRICATION section of this manual.
7. Check lubricant in crane drive gear housing or housings. Oil level should be even with oil level plug in housing. If additional gear housing lubricant is required, refer to the LUBRICATION section of this manual. Lubricate any exposed gears and pinions on the crane drives with the open gear lubricant supplied with the crane.
8. Remove drain plug, if provided, from the lowest position of the crane drive motor. This will allow moisture to escape so that it does not condense and accumulate inside the motor housing.
9. Check that the monorail, and other supporting structure where the crane will be installed has a load rating capable to handle loads equal to the rated load capacity of the crane.
10. Check that runway stops are installed, or install runway stops, at the open end or ends of the runway monorail to prevent the crane from traveling off the runway monorail beam. Runway stops that engage crane end truck wheels are not recommended. Check that runway stops will prevent overhanging parts of the crane, and any hoist installed on the crane, from interfering with other equipment beyond the ends of the runway monorail.
11. Warning signs and barriers shall be utilized on the floor area beneath the runway where the crane will be installed.

 **DANGER**

12. The main switch (disconnect) supplying power to the runway shall be de-energized. Lock and tag the main switch in the de-energized position in accordance with ANSI Z244.1.

13. If the crane is to be installed on an existing runway, and the crane runway remains energized because of other cranes operating on the same runway; stops or a signal person(s), located full-time at a visual vantage point for observing the approach of an active crane(s), shall be provided to prohibit contact by the active crane(s) with the crane being installed, and personnel involved in installing the crane. HOWEVER,

 **DANGER**

After the crane has been positioned on the runway, and prior to connecting the crane to the runway electrification, the main switch (disconnect) supplying power to the runway shall be de-energized. Lock and tag the main switch in the de-energized position in accordance with ANSI Z244.1.

INSTALLATION

14. If personnel will be required to work on the runway during installation, a guard or barrier shall be installed between adjacent runways for the length of the established work area to prevent contact between persons performing installation and a crane on the adjacent runway.
15. If personnel are required to work at elevations in excess of 6 feet above floor or ground level, a fall prevention policy and procedure shall be developed, documented, and implemented prior to installation being started.
16. Check power supply that will be furnished to the crane. It must be the same as shown on the crane serial plate.
 - a. Standard crane drive single-speed motors are reconnectable for 208/230 volt or 460 volt, three-phase, 60 Hz. operation. Such motors and control will be connected at the factory for 460 volt unless otherwise specified.
 - b. All two-speed motors, 200 volt single-speed motors, and 575 volt single-speed motors are single voltage motors, and are not reconnectable.
 - c. If the power supply that will be furnished to the crane is not the same as shown on the crane serial plate for two-speed, 200 volt single-speed, and 575 volt single-speed cranes; DO NOT INSTALL. Contact Acco Chain & Lifting Products or the distributor of the crane.
 - d. If reconnection of a 230/460 volt motor is required, proceed as follows:
 - (1) If crane is connected to the main power supply, de-energize, lock, and tag the main switch (disconnect) in accordance with step 12 of "PRIOR TO INSTALLING CRANE" instructions.
 - (2) Reconnect the control circuit transformer, located inside the control enclosure. Connection instructions are located on the transformer and in the ELECTRICAL COMPONENTS section of this manual.
 - (3) Reconnect the crane drive motor leads, and crane drive motor brake leads located inside the crane motor junction box. Connection instructions are located in the ELECTRICAL COMPONENTS section of this manual.
 - (4) If the crane is equipped with optional motor circuit fuses or overload relays sized for the original connection voltage, they must be replaced with ones properly sized for the reconnected voltage.
 - (5) If the crane is equipped with other optional features effected by power supply voltage, reconnect as per instructions included on the component or other sections of the manual.
17. Conductors supplying power to the crane and associated equipment must be sized to maintain the operating voltage at the crane at plus or minus 10% of the nominal operating voltage at all times. Standard nominal operating voltages are 200, 208, 230, 460, and 575 volts.
18. Conductors supplying power to the crane and associated equipment must be protected against short circuit and over-current conditions in compliance with ANSI/NFPA 70, National Electrical Code. These requirements are listed in Article 610 and are the responsibility of the owner/user. It is also the responsibility of the owner/user to insure that all protective devices and associated wiring comply with applicable Federal, State, and Local Codes.
19. Every LOUDEN® crane, except hand-propelled types, is fully assembled at the factory prior to shipment. Some cranes are disassembled to facilitate shipment, but the original assembly assures that all parts fit and that the crane is complete. General crane shipping practices are as follows:
 - a. Motor driven cranes are normally shipped partially disassembled.
 - b. Crane drive units for steel-wheel drive cranes are shipped loose with four-wheel end truck packages, or attached to the four-wheel drive trolley assembly with eight-wheel end truck packages.
 - c. Idler trolleys are attached to four-wheel end trucks and shipped loose with eight-wheel end truck packages.
 - d. End trucks are normally attached to the crane bridge beam unless the overall truck length exceeds eight feet.
 - e. Collector brackets are normally shipped loose.
 - f. Bridge electrification is normally shipped loose. If bridge electrification is shipped loose, it is recommended that it be installed on the crane bridge while the crane is on the floor before installing the crane on the runways.

INSTALLATION

20. Check and confirm that all crane components and items have been received. If any items are missing, contact Acco Chain & Lifting Products or the distributor of the crane.
21. Place crane or crane components in correct position directly below the crane runway. Verify that crane electrification and runway electrification are properly positioned.
22. Check that runway centers and crane span are correct.
23. Rotate all end truck wheels by hand to check for possible damage during shipment. Check for rough bearings, loose bearings, and loose axles. Do not install a damaged crane. Replace damaged parts and file a claim with the carrier.

INSTALLING SINGLE GIRDER HAND-PROPELLED CRANES:

1. Remove trolleys from end trucks. Install trolleys on the runway monorail in the same relative position that the crane was oriented on the floor, as follows:

- a. Four-wheel end trucks have two-wheel trolleys at each end of the truck. Disassemble trolleys from the truck loadbar by removing the bolt and spacer that passes through the trolley yoke above the loadbar. Remove runway stops from the runway monorail and guide the trolleys onto the runway monorail. After installing the trolleys on the runway monorail, re-install runway stops on the runway monorail.

If an open end of runway monorail is not available for guiding the trolleys onto the runway monorail, remove one wheel and axle assembly from the trolley. Place the other wheel, still assembled to the trolley, on the monorail and replace the wheel and axle assembly to the trolley.

Bronze washers are to be coated with Lubriplate 630-AA or 630-2 and seated on the trolley yoke with the hardened steel washer on top of the bronze washer. Trolleys can be reassembled to the truck loadbar when the bridge and end trucks are lifted into position at final assembly.

- b. Eight-wheel end trucks have four-wheel trolleys at each end of the truck. Trolleys are shipped loose, and saddle plates are bolted to the end truck channels. Saddle plates rest on top of the four-wheel trolley loadbars. Disassemble saddle plate from end truck channels. Check bronze washers. Bronze washers are to be coated with Lubriplate 630-AA or 630-2 and seated on the trolley loadbar. Place saddle plate on loadbar. Remove runway stops from the runway monorail and guide the trolleys onto the runway monorail. After installing the trolleys on the runway monorail, re-install runway stops on the runway monorail.

If an open end of runway monorail is not available for guiding the trolleys onto the runway monorail, remove one wheel and axle assembly from each trolley. Place the other wheels, still assembled to the trolleys, on the monorail and replace the wheel and axle assemblies to the trolleys.

Trolleys and saddle plates can be reassembled to the end truck when the bridge and end trucks are lifted into position at final assembly.

2. Assemble the end trucks to the bridge girder if not already assembled. Lift the bridge girder and end trucks into position and attach to trolley yokes or saddle plates.
3. Check squareness of bridge and end trucks. Place a carpenter's square against the web of the bridge girder and the inside of one end truck channel. Do this on both sides of the web of the bridge girder. Adjust the end truck placement so both sides read the same. Then check span at the end truck adaptor pins at each end of the end trucks. Allowable tolerance $\pm 1/16$ inch. Adjust the other end truck as required. Then check diagonals between end truck wheel centers. Allowable tolerance of diagonals, $\pm 1/8$ inch of each other.
4. Make sure all crane assembly bolts are in place and are tight.
5. If a power-operated hoist is to be used on the crane, and runway electrification is provided through collectors, check that collectors are positioned for proper contact with conductors.

INSTALLATION

SPRING LOADED COLLECTORS – Set midway between free state and collapsed state.

TOW TYPE COLLECTORS – Make sure they are properly seated and towing harness is not fouled.

6. If end truck bumpers are provided, check that they meet stops on runway beam, and reposition stops if necessary.
7. Check that end stops are installed on all open ends of the bridge girder.

INSTALLING SINGLE GIRDER MOTORIZED CRANES:

Instructions for installing motorized cranes are outlined below. Follow step 1 according to the type and style of end truck trolleys specified. Steps 2 through 8 apply to any crane.

1. Remove trolleys from end trucks. Install trolleys on the runway monorail in the same relative position that the crane was oriented on the floor, as follows:

IDLER TROLLEYS – SUPERTRACK END TRUCKS (4½ INCH DIAMETER WHEELS)

- a. Four-wheel end trucks have two-wheel trolleys at each end of the truck. Disassemble trolleys from the truck loadbar by removing the bolt and spacer that passes through the trolley yoke above the loadbar. Remove runway stops from the runway monorail and guide the trolleys onto the runway monorail. After installing the trolleys on the runway monorail, re-install runway stops on the runway monorail.

If an open end of runway monorail is not available for guiding the trolleys onto the runway monorail, remove one wheel and axle assembly from the trolley. Place the other wheel, still assembled to the trolley, on the monorail and replace the wheel and axle assembly to the trolley.

Bronze washers are to be coated with Lubriplate 630-AA or 630-2 and seated on the trolley yoke with the hardened steel washer on top of the bronze washer. Trolleys can be reassembled to the truck loadbar when the bridge and end trucks are lifted into position at final assembly.

- b. Eight-wheel end trucks have four-wheel trolleys at each end of the truck. Trolleys are shipped loose, and saddle plates are bolted to the end truck channels. Saddle plates rest on top of the four-wheel trolley loadbars. Disassemble saddle plate from end truck channels. Check bronze washers. Bronze washers are to be coated with Lubriplate 630-AA or 630-2 and seated on the trolley loadbar. Place saddle plate on loadbar. Remove runway stops from the runway monorail and guide the trolleys onto the runway monorail. After installing the trolleys on the runway monorail, re-install runway stops on the runway monorail.

If an open end of runway monorail is not available for guiding the trolleys onto the runway monorail, remove one wheel and axle assembly from each trolley. Place the other wheels, still assembled to the trolleys, on the monorail and replace the wheel and axle assemblies to the trolleys.

Trolleys and saddle plates can be reassembled to the end truck when the bridge and end trucks are lifted into position at final assembly.

IDLER TROLLEYS – TROJANTRACK END TRUCKS (9 INCH DIAMETER WHEELS)

- a. Four-wheel end trucks have two-wheel trolleys at each end of the truck, mounted on trolley adapters that are bolted to the end truck channels. Each trolley has a grounding cable that is attached to an end truck channel. Disassemble trolley and adapter assemblies from end truck channels. Remove runway stops from the runway monorail and guide the trolley and adapter assemblies onto the runway monorail. After installing the trolley and adapter assemblies on the runway monorail, re-install runway stops on the runway monorail.

If an open end of runway monorail is not available for guiding the trolleys onto the runway monorail, remove one trolley sideplate with the wheel assembly intact. Place the other trolley sideplate, with wheel assembly intact, on the monorail and replace the trolley sideplate that was originally disassembled.

Trolleys and adapters can be reassembled to the end truck when the bridge and end trucks are lifted into position at final assembly.

INSTALLATION

- b. Eight-wheel end trucks have four-wheel trolleys at each end of the truck. Trolleys are shipped loose, and saddle plates are bolted to the end truck channels. Saddle plates rest on top of the four-wheel trolley loadbars. Disassemble saddle plate from end truck channels. Check bronze washers. Bronze washers are to be coated with Lubriplate 630-AA or 630-2 and seated on the trolley loadbar. Place saddle plate on loadbar. Remove runway stops from the runway monorail and guide the trolleys onto the runway monorail. After installing the trolleys on the runway monorail, re-install runway stops on the runway monorail.

If an open end of runway monorail is not available for guiding the trolleys onto the runway monorail, remove one trolley sideplate with the wheel assembly intact. Place the other trolley sideplate, with wheel assembly intact, on the monorail and replace the trolley sideplate that was originally disassembled.

Trolleys and saddle plates can be reassembled to the end truck when the bridge and end trucks are lifted into position at final assembly.

STEEL-WHEEL DRIVE UNIT TROLLEYS (4½ INCH DIAMETER WHEELS ONLY)

- a. Steel-wheel crane drive units are shipped loose with four-wheel end truck packages. Remove runway stops from the runway monorail and guide the steel-wheel crane drive trolley assembly onto the runway monorail. After installing the steel-wheel crane drive trolley on the runway monorail, re-install runway stops on the runway monorail.

If an open end of runway monorail is not available for guiding the steel-wheel crane drive trolley onto the runway monorail, remove the plain sideplate with the geared wheel assembly intact. Place the drive side of the unit on the monorail and replace the plain sideplate, without replacing the two 5/8 inch bolts and spacers. These bolts and spacers are to be replaced at final assembly of crane.

Bronze washers are to be coated with Lubriplate 630-AA or 630-2 and seated on the trolley yoke with the hardened steel washer on top of the bronze washer.

Steel-wheel drive unit trolley and idler trolleys can be reassembled to the end truck when the bridge and end trucks are lifted into position at final assembly.

- b. Steel-wheel crane drive units are attached to the four-wheel drive trolley assembly with eight-wheel end truck package. Trolleys are shipped loose, and saddle plates are bolted to the end truck channels. Saddle plates rest on top of the four-wheel trolley loadbars. Disassemble saddle plate from end truck channels. Check bronze washers. Bronze washers are to be coated with Lubriplate 630-AA or 630-2 and seated on the trolley loadbar. Place saddle plate on loadbar. Remove runway stops from the runway monorail and guide the assembled trolleys and saddle plates onto the runway monorail. After installing the trolleys and saddle plates on the runway monorail, re-install runway stops on the runway monorail.

If an open end of runway monorail is not available for guiding the trolleys and saddle plates onto the runway monorail, remove the plain sideplate with the geared wheel assembly intact from the steel-wheel crane drive unit, and one wheel and axle assembly from the idler trolley, on the same side as the plain sideplate of the steel-wheel crane drive trolley. Place the drive side wheels of the unit on the monorail and replace the wheel and axle assembly to the idler trolley, and the plain sideplate to the steel-wheel drive unit, without replacing the two 5/8 inch bolts and spacers. These bolts and spacers are to be replaced at final assembly of crane.

Trolleys and saddle plates can be reassembled to the end truck when the bridge and end trucks are lifted into position at final assembly.

2. Assemble the end trucks to the bridge girder if not already assembled.
3. Check squareness of bridge and end trucks. Place a carpenter's square against the web of the bridge girder and the inside of one end truck channel. Do this on both sides of the web of the bridge girder. Adjust the end truck placement so both sides read the same. For double girder cranes with two trucks at each end, site down the first end truck to line up the second end truck, or pull a tight line along the inside of the end trucks. Then check span at the end truck adaptor pins at each end of the end trucks. Allowable tolerance $\pm 1/16$ inch. Adjust the other end truck as required. Then check diagonals between end truck wheel centers. Allowable tolerance of diagonals, $\pm 1/8$ inch of each other.

INSTALLATION

4. Lift the bridge girder and end trucks into position and attach to trolley yokes or saddle plates, as follows:
 - a. Disassemble restraining lugs from end trucks.
 - b. For cranes with rubber tire drives, lower the drive tires to a point where the top surface of the tire will be approximately 2 inches below runway (approximately level with the bottom of the end truck channel).
 - c. Lift entire crane as close to runway monorail rails as possible. Move idler trolleys and/or steel-wheel crane drive unit in under end trucks from each end. Lower crane down onto trolleys or loadbars.
 - d. Secure trolleys in place with previously removed bolts.
 - e. Reinstall restraining lugs.
5. Make sure all crane assembly bolts are in place and are tight.
6. For crane with drive tires only:
 - a. Raise drive tires to bottom surface of runway monorails. Make sure that tires have equal pressure against bottom surface of rails.
 - b. Adjust drive tires against bottom surface of runway monorails. Adjust just enough so that tire will not slip when operating at full load. Tire slippage will accelerate tire wear; however, excessive tightening will place excessive loads on motors, shafts, bearings, and wheels.
 - c. Check that drive shaft couplings are tight and that keys are in place.
7. If a power-operated hoist is to be used on the crane, and runway electrification is provided through collectors, check that collectors are positioned for proper contact with conductors.

SPRING LOADED COLLECTORS - Set midway between free state and collapsed state.

TOW TYPE COLLECTORS - Make sure they are properly seated and towing harness is not fouled.
8. If end truck bumpers are provided, check that they meet stops on runway beam, and reposition stops if necessary.
9. Check that end stops are installed on all open ends of the bridge girder.
10. If crane system includes interlocks, transfer sections, or other optional devices, refer to Manual 69879: Installation, Operation, Maintenance, and Parts Manual for LOUDEN® Underhung Crane and Monorail Accessories

INSTALLING DOUBLE GIRDER MOTORIZED CRANES: INSTALLING SINGLE GIRDER TRUSS MOTORIZED CRANES: INSTALLING DOUBLE GIRDER TRUSS MOTORIZED CRANES:

1. Refer to crane assembly drawing. Assemble the crane, matching marks made on components prior to disassembly at the factory.
 - a. Double girder cranes:
 - (1) Position and attach bridge girders to end trucks.
 - (2) Attach all bracing, and drive shaft assembly, as applicable.
 - (3) Tighten all nuts with sufficient torque to flatten lockwashers.
 - b. Truss cranes (both single and double girder):
 - (1) Position and attach trusses to end trucks.
 - (2) Attach all bridge support members, bridge girder or girders, bracing, and drive shaft assembly, as applicable.
 - (3) Tighten all nuts with sufficient torque to flatten lockwashers.
2. Install trolleys on the runway monorail and install crane in accordance with "INSTALLING SINGLE GIRDER MOTORIZED CRANES" instructions.

INSTALLING CONTINUED FOR ALL CRANES:

If pendant control cable is too long, it may be shortened only under the following conditions:

1. Only a qualified electrician should perform this work.

INSTALLATION

2. If crane is connected to the main power supply, de-energize, lock, and tag the tag the main switch (disconnect) in accordance with step 12 of "PRIOR TO INSTALLING CRANE" instructions.
3. Shorten cable at the crane control end. DO NOT disturb connections inside the pendant station.
4. Check that all wires shortened are reconnected the same as originally connected. Refer to electrical wiring diagram located inside control enclosure.
5. Shorten the strain chain an amount equal to the length the cable was shortened. This is to assure that any strain caused by pulling on the pendant control will be absorbed by the strain chain. To check, pull firmly on the pendant station. When strain chain becomes taut, there should be some slack in the cable. If cable is taut and strain chain is slack, remove additional length of strain chain. DO NOT USE until a condition of taut strain chain and slack cable is achieved.

CONNECTING POWER SUPPLY TO CRANE:



1. DISCONNECT POWER AND LOCKOUT DISCONNECTING MEANS BEFORE CONNECTING POWER SUPPLY TO CRANE.
2. Only a qualified electrician should connect the power supply to the crane.
3. Check power supply that will be furnished to the crane. It must be the same as shown on the crane serial number plate. If the power supply that will be connected to the crane is not the same as shown on the crane serial number plate, DO NOT connect power supply to crane. Refer to step 15 of "PRIOR TO INSTALLING CRANE" instructions.
4. Make all electrical connections in accordance with wiring diagram located in control enclosure.

BEFORE OPERATING CRANE:

1. Before energizing the power supply, and inspecting and testing the crane prior to initial operational use, check that all electrical connections are in accordance with the wiring diagram located in crane control enclosure.
2. ASME B30.11 requires that all new, altered, or modified cranes be inspected by a designated person prior to initial use to verify that the equipment and installation comply with applicable provisions of the standard. Such an inspection should be performed at this time, using ASME B30.11 as the basis for inspection procedures.
3. Energize the power supply to the crane.
4. Check crane travel for correct crane motion direction (crane drive motor or motors are properly phased). Since motor rotation of a three-phase AC motor can be changed by reversing any two of the lines feeding power to the motor, the direction of crane motion must be checked to verify that it is correct in accordance with the crane control device markings.

To check crane motion direction or crane drive motor phasing:

MOMENTARILY activate one button or lever of the crane control device and observe the direction of crane motion. If direction of crane travel agrees with the direction marking of the crane control device activated (i.e., crane direction is EAST when the crane EAST control device is activated), crane motor is properly phased. If the direction of crane travel does not agree with the direction marking of the crane control device activated (i.e., crane direction is WEST when the crane EAST control device is activated), crane motor is improperly phased and must be corrected. DO NOT USE CRANE until motor phasing is corrected.

INSTALLATION

WARNING

DO NOT OPERATE CRANE IF DIRECTION OF CRANE MOTION DOES NOT AGREE WITH THE DIRECTION MARKING ON THE CRANE CONTROL DEVICE ACTIVATED.

WARNING

DO NOT ATTEMPT TO CORRECT AN IMPROPERLY PHASED CRANE BY CHANGING ANY WIRING IN THE CRANE CONTROL DEVICE OR AT THE CRANE CONTACTORS; OR BY CHANGING THE MARKINGS ON THE CRANE CONTROL DEVICE.

To correct crane motor phasing:

DANGER

- a. DISCONNECT POWER AND LOCKOUT DISCONNECTING MEANS BEFORE RECONNECTING (REVERSING) POWER LINES TO CRANE.
 - b. Only a qualified electrician should reconnect the power lines to the crane.
 - c. Interchange any two lines supplying power to the crane motor only. DO NOT reverse main power leads to the crane as this will also effect the phasing of other motors in the system (i.e. hoist motors).
 - d. Re-energize power supply to the crane.
 - e. Re-check crane travel for correct crane motion. If direction of crane travel agrees with the direction marking of the crane control device activated (i.e., crane direction is EAST when the crane EAST control device is activated), crane motor is properly phased. If the direction of crane travel does not agree with the direction marking of the crane control device activated (i.e., crane direction is WEST when the crane EAST control device is activated), crane motor is improperly phased and must be corrected by repeating steps a through e.
6. If a trolley hoist is mounted on the crane, check that end stops are installed on all open ends of the bridge girder or girders. If end stops are not present on all open ends, DO NOT operate trolley hoist until end stops are installed.
 7. Operate crane in both travel directions, without load on the crane, and stop motion to check operation of the crane drive motor brake. The crane should stop within a distance equal to 10% of the full load travel speed of the crane. If the crane does not stop within this distance, the crane drive motor brake requires adjustment. Refer to the CRANE MOTOR BRAKE section of this manual for instructions on motor brake adjustment.
 8. If travel limit switches are installed on the runway or bridge girders, operate the crane or trolley hoist to verify limit switch operation.
 9. Operate the crane, without a load on the crane, for the entire travel distance of the runway monorail to check that crane and trolley hoist do not interfere with any other items or pieces of equipment located in the path of travel.
 10. If crane has a trolley hoist, operate the trolley hoist, without a load on the hoist hook, for the entire travel distance of the trolley to check that trolley, hoist, load block, and hook do not interfere with any other items or pieces of equipment located in the path of travel.
 11. If crane operates in a system with interlocks or transfer sections, operate crane or trolley through all such devices to verify alignment and operation.

INSTALLATION

12. Check operation of ACM V and adjust as required. Refer to ACCELERATION CONTROL MODULE V section of this manual.

CRANE LOAD TEST:

1. Complete cranes must be load tested in accordance with ASME B30.11. Therefore, it is the responsibility of the owner/user to load test the crane or final lifting system in accordance with ASME B30.11.
2. All personnel that will operate the crane or trolley hoist shall read: the OPERATION section of this manual, the WARNINGS contained in this manual; instruction and WARNING labels on the crane; the instruction manual furnished with the hoist; and instruction and WARNING labels on the hoist before operating the hoist or lifting system.

OPERATION

Operation of an underhung crane usually includes the operation of an overhead hoist. Information in this section addresses both the crane and hoist; however, the operation section of the manual furnished with the hoist must be reviewed for specific operation procedures that apply to the hoist.

Operation of an overhead hoist and crane involves more than activating the buttons or levers of the hoist and crane control devices. It is emphasized in the ASME B30 Standards that the use of overhead hoists and cranes are subject to certain hazards that cannot be met by mechanical means, but only by the exercise of intelligence, care, common sense, and experience in anticipating the motions that will occur as a result of activating the hoist or crane controls. Certain precautions are necessary before moving the load and this includes the proper rigging of loads to the hoist hook.

WARNING

CRANE AND HOIST OPERATORS SHALL BE REQUIRED TO READ THE OPERATION SECTION OF THIS MANUAL, THE WARNINGS CONTAINED IN THIS MANUAL, INSTRUCTION AND WARNING LABELS ON THE CRANE, THE OPERATION SECTION AND WARNINGS CONTAINED IN THE MANUAL FURNISHED WITH THE HOIST, INSTRUCTION AND WARNING LABELS ON THE HOIST, AND THE OPERATION SECTIONS OF ASME B30.11 AND ASME B30.16; AND TO BE FAMILIAR WITH THE CRANE AND HOIST, AND CRANE AND HOIST CONTROLS BEFORE BEING AUTHORIZED TO OPERATE THE CRANE AND HOIST OR LIFTING SYSTEM.

CRANE AND HOIST OPERATORS SHOULD BE TRAINED IN PROPER RIGGING PROCEDURES TO BE FOLLOWED IN THE ATTACHMENT OF LOADS TO THE HOIST HOOK.

CRANE AND HOIST OPERATORS SHOULD BE TRAINED TO BE AWARE OF POTENTIAL MALFUNCTIONS OF THE EQUIPMENT THAT REQUIRE ADJUSTMENT OR REPAIR, AND TO BE INSTRUCTED TO STOP OPERATION IF SUCH MALFUNCTIONS OCCUR, AND TO IMMEDIATELY ADVISE THEIR SUPERVISOR SO CORRECTIVE ACTION CAN BE TAKEN.

CRANE AND HOIST OPERATORS SHOULD HAVE NORMAL DEPTH PERCEPTION, FIELD OF VISION, REACTION TIME, MANUAL DEXTERITY, AND COORDINATION.

CRANE AND HOIST OPERATORS SHOULD NOT BE SUBJECT TO SEIZURES, LOSS OF PHYSICAL CONTROL, PHYSICAL DEFECTS, OR EMOTIONAL INSTABILITY THAT COULD RESULT IN ACTIONS OF THE OPERATOR BEING A HAZARD TO THE OPERATOR OR OTHERS.

CRANE AND HOIST OPERATORS SHOULD NOT OPERATE A CRANE, HOIST OR LIFTING SYSTEM WHEN UNDER THE INFLUENCE OF ALCOHOL, DRUGS, OR MEDICATION.

CRANES AND OVERHEAD HOISTS ARE INTENDED ONLY FOR VERTICAL LIFTING SERVICE OF FREELY SUSPENDED UNGUIDED LOADS. DO NOT USE CRANE OR HOIST FOR LOADS THAT ARE NOT LIFTED VERTICALLY, LOADS THAT ARE NOT FREELY-SUSPENDED, OR LOADS THAT ARE GUIDED. IF SUCH CONDITIONS EXIST, CONTACT ACCO CHAIN & LIFTING PRODUCTS.

BEFORE EACH SHIFT OR BEFORE THE FIRST TIME THE CRANE IS TO BE USED EACH SHIFT:

THE OPERATOR:

SHALL visually inspect wire rope for broken wires, broken strands, kinks, and any type of deformation or damage of the rope structure.

SHALL visually inspect hooks for nicks, gouges, deformation of the throat opening, wear on saddle or load bearing point, and twisting.

SHALL replace warning label or labels if missing or illegible.

OPERATION

SHALL report any damage or malfunctions to the supervisor.

SHALL NOT operate crane or hoist if any damage or malfunctions exist.

SHALL NOT operate crane or hoist if it is tagged with an out-of-order sign.

BEFORE OPERATING THE CRANE AND APPLYING THE LOAD:

THE OPERATOR:

SHALL be familiar with all operating controls of the crane and hoist.

SHALL be familiar with the OPERATION Section of this manual, the WARNINGS contained in this manual, instructions and WARNING labels on the crane and hoist or lifting system, the OPERATION section of the manual furnished with the hoist, and the OPERATION Sections of ASME B30.11 and ASME B30.16.

SHALL be instructed in the operation or operations to be performed.

SHALL NOT operate crane or hoist if any damage or malfunctions exist; and SHALL report any damage or malfunctions to the supervisor.

SHALL NOT operate crane or hoist if it is tagged with an out-of-order sign.

SHALL center crane and hoist over load.

SHALL NOT use the hoist wire rope as a sling to wrap around the load.

SHALL attach the load to the hoist hook by suitable means such as slings or lifting devices.

SHALL only attach loads to the hoist hook that do not exceed the rated load capacity of the crane or hoist.

SHALL verify that the size of the attachment of the sling or other lifting device to be used is compatible with the size of the hoist hook.

SHALL verify that the attachment part of the sling or other lifting device is properly seated in the base, bowl, or saddle of the hoist hook.

SHALL verify that the hook latch operates properly and that the hook latch properly bridges and closes the hook throat opening.

SHALL verify that the latch of the hoist hook will not support any part of the load.

SHALL verify that the load or any part of the load will not be applied to and/or not supported by the tip or point of the hook.

SHALL verify that load will be properly balanced when it is lifted.

SHALL verify that side loads will not be applied to the crane or hoist when the load is lifted.

SHALL verify that hoist wire rope is not kinked or twisted, and that wire rope parts are not twisted about each other.

SHALL verify that hoist wire rope is properly seated in the drum grooves and sheaves.

SHALL notify personnel in the area that a load will be lifted and verify that all personnel are clear of the load.

SHALL verify that when the load is lifted, it will clear all material, machinery, or other obstructions in the area.

OPERATION

WHILE OPERATING THE CRANE AND MOVING THE LOAD:

THE OPERATOR:

SHALL NOT engage in any activity that will divert the attention of the operator.

SHALL NOT lift, lower, or transport a load with the crane or hoist until the operator and all other personnel are clear of the load and the path of the load.

SHALL verify that the load, crane, and hoist will clear all obstacles before moving or rotating the load.

SHALL avoid moving loads over personnel.

SHALL NOT lift, lower, or transport personnel by means of the crane, hoist, trolley, hoist hook, or load.

SHALL slowly inch the hook into engagement with the load to eliminate wire rope slack and reduce impact loading of the crane and hoist.

SHALL avoid unnecessary inching and quick reversals of direction.

SHALL only lift the load a few inches to verify that the load is properly balanced before continuing with the lift.

SHALL only lift the load a few inches to verify that the hoist braking system is functioning properly before continuing with the lift.

SHALL only traverse the load a few inches to verify that the crane braking system is functioning properly before continuing with travel.

SHALL avoid swinging of the load or hoist hook when the crane and/or hoist is traveling.

SHALL avoid sharp contact between trolleys or between trolleys and stops.

SHALL avoid sharp contact between cranes or between cranes and stops.

SHALL NOT use hoist limit switches or devices as a normal means of stopping the hoist.

SHALL NOT lower the load beyond the point where less than two wraps of wire rope remain at each anchorage on the drum, unless a lower limit device is provided, in which case no less than one wrap of wire rope shall remain at each anchorage on the drum.

PARKING THE LOAD:

THE OPERATOR:

SHALL NOT lower a load with the hoist until the operator and all other personnel are clear of the load and the path of the load.

SHALL verify that the load will clear all obstacles before lowering the load.

SHALL block loads before landing if slings or other lifting devices must be removed from under the landed load.

SHALL exercise care when removing a sling from under a landed and blocked load.

SHALL NOT leave a suspended load unattended unless specific precautions to prevent the load from inadvertent lowering have been instituted and are in place.

SHALL position the hoist load block and hook above head level for storage when the hoist is not in use.

OPERATION

GENERAL:

THE OPERATOR:

SHALL know hand signals used for hoist and crane operations if a signal-person is used in the operation, and accept signals of only persons authorized to give hand signals EXCEPT to obey a stop signal regardless who gives it.

SHALL NOT adjust or repair a crane or hoist unless qualified and authorized to perform maintenance.

SHALL NOT use a hoist load limiting device as a means to measure the load.

GENERAL DO'S AND DO NOT'S:

DO establish a regular inspection schedule and maintain a record of all inspections performed with special attention directed to wire ropes, hooks, and brakes.

DO remove the crane and hoist from service to perform necessary maintenance and repair.

DO follow recommended maintenance procedures for taking a crane and hoist out of service to inspect and perform maintenance and repair.

DO use the original crane and hoist manufacturer's recommended parts when repairing a crane or hoist and replacing worn or damaged parts.

DO NOT allow unqualified or unauthorized personnel to operate, inspect, maintain, or repair a crane or hoist.

DO NOT operate a crane and hoist that is damaged or has any actual or suspected mechanical or electrical malfunction.

DO NOT attempt to lengthen wire rope or repair damaged wire rope.

DO NOT use the wire rope, any part of the crane, hoist, or the load block and hook as a ground for welding.

DO NOT allow a welding electrode to be touched to the wire rope.

DO NOT remove or obscure any warnings or warning labels on the crane or hoist.

DO NOT walk under a suspended load.

DO NOT perform ANY work on a suspended load that requires a worker to be positioned under the suspended load.

WARNING

DO NOT WALK UNDER A SUSPENDED LOAD.

DO NOT PERFORM ANY WORK ON A SUSPENDED LOAD THAT REQUIRES A WORKER TO BE POSITIONED UNDER THE SUSPENDED LOAD.

IF IT IS ESSENTIAL THAT A WORKER BE POSITIONED UNDER A SUSPENDED LOAD TO PERFORM WORK ON THE SUSPENDED LOAD; SUCH WORK SHALL NOT BE STARTED OR PERFORMED UNTIL OTHER AUXILIARY SUPPORTING MEANS ARE PLACED UNDER THE SUSPENDED LOAD. FAILURE TO USE OTHER AUXILIARY SUPPORTING MEANS COULD RESULT IN SERIOUS BODILY INJURY OR DEATH, AND/OR PROPERTY DAMAGE.

MOTOR OVERLOAD FEATURES

Complete cranes are furnished with a motor overload feature. This feature de-energizes the crane drive motor or the crane drive control circuit for the purpose of stopping operation of the crane when a condition arises that makes it unwise, or even hazardous, for continued operation. Therefore, if the crane should stop during operation, or if the crane should fail to move a load, first consider and investigate any motor overload features. Standard features, unless otherwise specified, on complete cranes include:

- Motor Thermostats

MOTOR THERMOSTATS:

A bi-metallic, automatic thermostat is built into the motor windings. This thermostat will cause the motor control to be de-energized when the temperature of the motor winding exceeds a predetermined temperature limit. It provides full running protection against motor overheating. The motor control will continue to be de-energized until the temperature of the winding is reduced below the temperature cutoff point and then the crane may be operated as before.

OPTIONAL ITEMS:

Other motor overload features may be furnished on the crane as specified; furnished by others as part of a crane or lifting system ; or installed as part of the system or building by the installer or owner/user of the crane as required by ANSI/NFPA 70, National Electrical Code, or applicable Federal, State, or Local Codes. Such items could include thermal overload relays, branch circuit fuses, or main line fuses. Refer to the wiring diagram enclosed in the crane control enclosure to determine if any additional motor overload features are furnished with the crane. If the crane is installed in a lifting system designed and manufactured by others, refer to the wiring diagram for the crane or lifting system to determine if any additional motor overload features are furnished as part of the crane or lifting system.

MAINTENANCE AND INSPECTION PROCEDURES

Cranes shall be maintained, inspected, and tested in accordance with the MAINTENANCE AND REPAIR, INSPECTION, and TEST sections of this manual and in accordance with the intervals and requirements of ASME B30.11. Hoists shall be maintained, inspected, and tested in accordance with the manual furnished by the hoist manufacturer and in accordance with the intervals and requirements of ASME B30.16.

Before maintenance or inspections are performed on a hoist, trolley, crane, crane runway, crane runway or monorail support, or crane runway or monorail conductors, the following precautions shall be taken as applicable.

1. The hoist, trolley, or crane to be inspected, tested, or repaired shall be run to a location where it will cause the least interference with other hoists, cranes, and operations in the area.
2. If a load is attached to the crane, it shall be landed.
3. All controllers shall be placed in the off position.
4. If a trolley hoist is installed on the crane, the trolley shall be blocked to prevent trolley movement.
5. The crane shall be blocked to prevent crane movement.

DANGER

6. HAZARDOUS VOLTAGES ARE PRESENT IN THE CONTROL BOX, OTHER ELECTRICAL COMPONENTS, AND CONNECTIONS BETWEEN THESE COMPONENTS.

The main switch (disconnect) of the hoist, crane, or lifting system shall be de-energized. Lock and tag the main switch in the de-energized position in accordance with ANSI Z244.1.

7. Warning signs and barriers shall be utilized on the floor beneath the hoist, crane, or lifting system where overhead maintenance, repair, or inspection work creates a hazardous area on the floor beneath the hoist, crane, or lifting system.
8. If the crane runway remains energized because other cranes on the same runway are in operation, rail stops or a signal person(s), located full-time at a visual vantage point for observing the approach of an active crane(s), shall be provided to prohibit contact by the active crane(s) with the idle crane; with persons performing maintenance, repair, or inspection; and with equipment used in performing the maintenance, repair, or inspection.
9. A guard or barrier shall be installed between adjacent runways for the length of the established work area to prevent contact between persons performing maintenance, repair, or inspection and a crane on the adjacent runway.
10. Safe access to the hoist, crane, or lifting system, such as scaffolding, work platforms, etc., shall be provided for personnel that will perform maintenance, repair, or inspection. If personnel are required to work at elevations in excess of 6 feet above floor or ground level, a fall prevention policy and procedure shall be developed, documented, and implemented by the owner/user.
11. After maintenance, repair, or inspection work is completed, and before the hoist, crane, or lifting system is returned to normal operation:
 - a. Any guards on the hoist, crane, or lifting system that were removed to perform maintenance, repair, or inspection work shall be reinstalled.
 - b. Any safety devices on the hoist, crane, or lifting system that were deactivated to perform maintenance, repair, or inspection work shall be reactivated.
 - c. Any parts that were replaced and other loose material shall be removed.
 - d. All equipment used in the maintenance, repair, or inspection work shall be removed.
12. Warning signs, barriers, and guards shall be removed only by authorized personnel.
13. Lock and tag on the main switch (disconnect) of the hoist, crane, or lifting device shall be removed only by the person that locked and tagged the main switch originally, or an authorized person.
14. If the extent of the maintenance or repair work requires any testing as outlined in the TEST SECTION of this manual; the manual furnished by the hoist manufacturer; or as required by, as applicable, the provisions of ASME B30.16, or ASME B30.11; such tests shall be conducted before the hoist, crane, or lifting system is returned to normal operation.

INSPECTION

Inspection procedure for cranes in regular service is divided into two general classifications as outlined in ASME B30.11. These two general classifications are based upon the intervals at which inspections should be performed. The intervals are dependent upon the nature of the critical components of the crane, and the degree of exposure of crane components and parts to wear and deterioration. The degree of exposure is dependent upon crane activity, severity of crane service, and the environment of crane location. These two general classifications of crane inspection are designated as frequent and periodic. In addition, daily inspections are required to be performed by the operator at the start of each shift, or at the time the crane is first used during each shift.

FREQUENT INSPECTION: Frequent inspections are visual inspections and examinations by the operator or other designated personnel with records not required. Nominal inspection intervals are as follows:

- Normal service** – monthly
- Heavy service** – weekly to monthly
- Severe service** – daily to weekly

PERIODIC INSPECTION: Periodic inspections are visual and audio inspections and examinations by designated personnel making records of external conditions to provide the basis for a continuing evaluation of the crane and components. If the external inspection indicates the need, some disassembly may be required to make a more detailed inspection and examination. Nominal inspection intervals are as follows:

- Normal service** – annually
- Heavy service** – semiannually
- Severe service** – quarterly

WARNING

THE INSPECTION INTERVALS LISTED ABOVE ARE NOMINAL RECOMMENDATIONS FOR REFERENCE PURPOSES ONLY. THEY ARE BASED ON SINGLE SHIFT OPERATION UNDER NORMAL OPERATING CONDITIONS AND NORMAL ENVIRONMENTAL CONDITIONS. ACTUAL OPERATING AND ENVIRONMENTAL CONDITIONS SHOULD BE REVIEWED BY A QUALIFIED PERSON AND INSPECTION INTERVALS ESTABLISHED ON THE RECOMMENDATIONS OF THE QUALIFIED PERSON.

Definitions of service from ASME B30.11 are as follows:

- Normal service** involves operation of the crane with randomly distributed loads within the rated load limit, or uniform loads less than 65% of rated load, for not more than 25% of the time for a single work shift.
- Heavy service** involves operation of the crane within the rated load limit that exceeds normal service.
- Severe service** involves operation of the hoist in normal service or heavy service with abnormal operating conditions.

A crane that is not in regular service, that has been idle for a period of one month or more, but less than one year, shall be inspected in accordance with the requirements for frequent inspection before being placed into service.

A crane that is not in regular service, that has been idle for a period of one year or more, shall be inspected in accordance with the requirements for periodic inspection before being placed into service.

INSPECTION

Required daily inspection items to be performed by the operator at the start of each shift, or at the time the crane is first used during each shift are shown in Table 1.

**TABLE 1
DAILY INSPECTIONS BY THE OPERATOR**

INSPECTION ITEM	DESCRIPTION OF INSPECTION CHECK POINTS
Tagged Crane	Check that crane is not tagged with an out-of-order sign.
Control Devices	Check that travel motions agree with control device markings.
Brakes	Check that crane travel motions do not have excessive drift.
Oil Leakage	Check for any sign of oil leakage on the crane and on the floor area beneath the crane.
Unusual Sounds	Check for any unusual sounds from the crane and crane mechanism while operating the crane.
Warning Label	Check that warning label is not missing and that it is legible.

NOTICE

IF A HOIST IS INSTALLED ON THE CRANE, REFER TO THE MANUAL FURNISHED WITH THE HOIST AND ASME B30.16 TO DETERMINE THE DAILY INSPECTION ITEMS THAT MUST BE PERFORMED BY THE OPERATOR.

⚠ WARNING

IF ANY DAMAGE OR MALFUNCTIONS ARE NOTED BY THE DAILY INSPECTION ITEMS OF TABLE 1, THE OPERATOR SHALL NOT OPERATE THE CRANE, AND SHALL IMMEDIATELY ADVISE THE SUPERVISOR SO CORRECTIVE ACTION CAN BE TAKEN. IF THE CRANE IS TAGGED WITH AN OUT-OF-ORDER SIGN, THE OPERATOR SHALL NOT OPERATE THE CRANE.

CRANE OPERATORS SHOULD BE TRAINED TO BE AWARE OF MALFUNCTIONS OF THE EQUIPMENT DURING OPERATION, AND TO IMMEDIATELY STOP OPERATION IF SUCH MALFUNCTIONS OCCUR, AND TO IMMEDIATELY ADVISE THE SUPERVISOR SO CORRECTIVE ACTION CAN BE TAKEN.

Recommended items to be checked for deficiencies or damage during frequent and periodic inspections are shown in Table 2. Detailed inspection procedures for some items will be found in specific sections of this manual. These inspections may be performed with the crane in its normal location and do not require that the crane be disassembled.

INSPECTION

Covers and other items normally supplied to allow inspection of components should be opened or removed for these inspections. Any deficiencies or damage such as those listed in Table 2 shall be examined by a designated person to determine whether they constitute a hazard, or whether any disassembly is necessary for a more detailed examination. The crane operator should make observations during regular operation for any deficiencies or damage that might appear between inspections.

**TABLE 2
FREQUENT AND PERIODIC INSPECTIONS**

INSPECTION ITEM	FREQUENCY		DEFICIENCIES OR DAMAGE TO LOOK FOR
	FREQUENT	PERIODIC	
All functional operating mechanisms	•	•	Maladjustment that interferes with proper operation and unusual sounds
Control devices	•	•	Improper operation
WARNING label	•	•	Missing or illegible
Control device markings	•	•	Missing or illegible
Lubricant levels (For detailed inspection procedures, refer to LUBRICATION section of this manual)	•	•	Lubricant must be added or replaced
Fastening devices (bolts, nuts, pins etc.)		•	Not properly secured (tightened), damaged or missing parts
Crane drive motor brake (For detailed inspection procedures, refer to MOTOR BRAKE section of this manual)		•	Drift and excessive wear
Supporting structure, end trucks, and trolley		•	Cracks, damage and distortion
Crane and trolley wheels		•	Flat spots, damage, excessive wear
End truck bronze thrust washers (For detailed inspection procedures, refer to LUBRICATION section of this manual)		•	Cracks, excessive wear, dirty lubricant
Electrical apparatus		•	Pitting, deterioration, wear
Contactors		•	Pitting, deterioration, wear, and improper operation
Wiring and fittings		•	Loose connections, abraded, cut, or nicked insulation

INSPECTION

NOTICE

IF A HOIST IS INSTALLED ON THE CRANE, REFER TO THE MANUAL FURNISHED WITH THE HOIST AND ASME B30.16 TO DETERMINE THE FREQUENT AND PERIODIC INSPECTION ITEMS THAT MUST BE PERFORMED.

⚠ WARNING

IF ANY DAMAGE OR MALFUNCTIONS ARE NOTED BY THE FREQUENT OR PERIODIC INSPECTION ITEMS OF TABLE 2, THE CRANE SHALL BE TAGGED WITH AN OUT-OF-ORDER SIGN AND SHALL NOT BE RETURNED TO REGULAR OPERATION UNTIL MAINTENANCE AND REPAIR OF THE DAMAGE OR DEFICIENCIES FOUND DURING THE INSPECTION HAVE BEEN CORRECTED.

Records of the condition of critical components such as wheels and brakes observed during frequent and periodic inspections should be established. This record should also record replacement, maintenance, and repair information. Use of this recorded information will allow a preventative maintenance program to be established for replacement of wearing components on a regular basis, thereby eliminating or reducing unscheduled downtime situations.

If maintenance, adjustment, replacement of parts, or repair of the crane is required because of any damage or malfunctions noted during the frequent or periodic inspections, refer to the MAINTENANCE AND REPAIR section of this manual and other sections of this manual for specific instructions or parts identification. Before performing any maintenance on the crane, refer to the MAINTENANCE AND INSPECTION PROCEDURES section of this manual. After performing maintenance, adjustment, or replacement of parts or components, refer to the TEST section of this manual.

TEST

During assembly of power-operated cranes, the crane manufacturer performs operational tests of the controls, motors, and crane drives. Because of the variations of each completed crane, this testing does not include operation of the crane on runway monorails, or load testing. Therefore, after installation, it is the responsibility of the owner/user to test the crane in accordance with ASME B30.11. If a hoist is installed on the crane, it is the responsibility of the owner/user to test the hoist in accordance with ASME B30.16, and instructions in the manual furnished with the hoist.

Testing of cranes after original installation is required when the crane has been altered, reinstalled, modified, or repaired; has been idle for a period of 12 months or longer; or in accordance with specific testing requirements established by the owner/user. General testing requirements are outlined in ASME B30.11 and should be followed. ASME B30.11 lists two types of tests as follows:

1. Operational test
2. Load Test

NOTICE

IF A HOIST IS INSTALLED ON THE CRANE, REFER TO THE MANUAL FURNISHED WITH THE HOIST AND ASME B30.16 TO DETERMINE TEST REQUIREMENTS FOR THE HOIST.

OPERATIONAL TEST:

All new, altered, reinstalled, modified, or repaired cranes, or cranes that have not been used within the preceding 12 months, SHALL be tested by the owner/user before being placed in operational service. The operational test is performed without a load on the crane and includes: (1) operation of control devices; (2) lifting and lowering; (3) operation of trolley travel; (4) operation of crane travel; and (4) operation and setting of devices for interlocking mechanisms, track switches, drop sections, lift sections, travel limit switches, and end stops.

Operational test steps are as follows:

1. If crane has a hoist, check hoist hook travel for correct hook motion (hoist motor is properly phased). Since motor rotation of a three-phase AC motor can be changed by reversing any two of the lines feeding power to the motor, the direction of hook motion must be checked to verify that it is correct in accordance with the hoist control device markings.

To check hook motion direction or motor phasing:

MOMENTARILY activate the UP button or lever of the hoist control device and observe the direction of hook motion. If direction of hook travel agrees with the direction marking of the hoist control device activated (i.e., hook direction is UP when the hoist UP control device is activated), hoist motor is properly phased. If the direction of hook travel does not agree with the direction marking of the hoist control device activated (i.e., hook direction is DOWN when the hoist UP control device is activated), hoist motor is improperly phased and must be corrected. DO NOT USE HOIST until motor phasing is corrected.

⚠ WARNING

DO NOT OPERATE HOIST IF DIRECTION OF HOOK MOTION DOES NOT AGREE WITH THE DIRECTION MARKING ON THE HOIST CONTROL DEVICE ACTIVATED.

⚠ WARNING

DO NOT ATTEMPT TO CORRECT AN IMPROPERLY PHASED HOIST BY CHANGING ANY WIRING IN THE HOIST CONTROL DEVICE OR AT THE HOIST CONTACTORS; OR BY CHANGING THE MARKINGS ON THE HOIST CONTROL DEVICE.

TEST

To correct hoist motor phasing: refer to the manual furnished with the hoist.

2. If crane has a motorized trolley, check trolley travel motion for agreement with the direction marking of the trolley control device.

To check trolley motion direction or trolley motor phasing:

MOMENTARILY activate one button or lever of the trolley control device and observe the direction of trolley motion. If direction of trolley travel agrees with the direction marking of the trolley control device activated (i.e., trolley direction is EAST when the trolley EAST control device is activated), trolley motor is properly phased. If the direction of trolley travel does not agree with the direction marking of the trolley control device activated (i.e., trolley direction is WEST when the trolley EAST control device is activated), trolley motor is improperly phased and must be corrected. DO NOT USE TROLLEY until motor phasing is corrected.

WARNING

DO NOT OPERATE TROLLEY IF DIRECTION OF TROLLEY MOTION DOES NOT AGREE WITH THE DIRECTION MARKING ON THE TROLLEY CONTROL DEVICE ACTIVATED.

WARNING

DO NOT ATTEMPT TO CORRECT AN IMPROPERLY PHASED TROLLEY BY CHANGING ANY WIRING IN THE TROLLEY CONTROL DEVICE OR AT THE TROLLEY CONTACTORS: OR BY CHANGING THE MARKINS ON THE TROLLEY CONTROL DEVICE.

To correct trolley motor phasing:

DANGER

- a. DISCONNECT POWER AND LOCKOUT DISCONNECTING MEANS BEFORE RECONNECTING (REVERSING) POWER LINES TO TROLLEY.
 - b. Only a qualified electrician should reconnect the power lines to the trolley.
 - c. Interchange any two lines supplying power to the trolley motor only. DO NOT reverse main power leads to the hoist or crane as this will also effect the phasing of the hoist and crane motors.
 - d. Re-energize power supply.
 - e. Re-check trolley travel for correct trolley motion. If direction of trolley travel agrees with the direction marking of the trolley control device activated (i.e., trolley direction is EAST when the trolley EAST control device is activated), trolley motor is properly phased. If the direction of trolley travel does not agree with the direction marking of the trolley control device activated (i.e., trolley direction is WEST when the trolley EAST control device is activated), trolley motor is improperly phased and must be corrected by repeating steps a through e.
3. Check crane travel motion for agreement with the direction marking of the crane control device.

To check crane motion direction or crane motor phasing:

MOMENTARILY activate one button or lever of the crane control device and observe the direction of crane motion. If direction of crane travel agrees with the direction marking of the crane control device activated (i.e., crane direction is EAST when the crane EAST control device is activated), crane motor is properly phased. If the direction of crane travel does not agree with the direction marking of the crane control device activated (i.e., crane direction is WEST when the crane EAST control device is activated), crane motor is improperly phased and must be corrected. DO NOT USE CRANE until motor phasing is corrected.

TEST

WARNING

DO NOT OPERATE CRANE IF DIRECTION OF CRANE MOTION DOES NOT AGREE WITH THE DIRECTION MARKING ON THE CRANE CONTROL DEVICE ACTIVATED.

WARNING

DO NOT ATTEMPT TO CORRECT AN IMPROPERLY PHASED CRANE BY CHANGING ANY WIRING IN THE CRANE CONTROL DEVICE OR AT THE CRANE CONTACTORS; OR BY CHANGING THE MARKINGS ON THE CRANE CONTROL DEVICE.

To correct crane motor phasing:

DANGER

- a. DISCONNECT POWER AND LOCKOUT DISCONNECTING MEANS BEFORE RECONNECTING (REVERSING) POWER LINES TO CRANE.
 - b. Only a qualified electrician should reconnect the power lines to the crane.
 - c. Interchange any two lines supplying power to the crane motor only. DO NOT reverse main power leads to the hoist or crane as this will also effect the phasing of the hoist and trolley motors.
 - d. Re-energize power supply.
 - e. Re-check crane travel for correct crane motion. If direction of crane travel agrees with the direction marking of the crane control device activated (i.e., crane direction is EAST when the crane EAST control device is activated), crane motor is properly phased. If the direction of crane travel does not agree with the direction marking of the crane control device activated (i.e., crane direction is WEST when the crane EAST control device is activated), crane motor is improperly phased and must be corrected by repeating steps a through e.
4. Operate hoist in the raising and lowering direction, without load on the hook, and stop motion to check operation of the hoist motor brake. Refer to the manual furnished with the hoist for instructions on hoist motor brake test and hoist motor brake adjustment.
 5. Check operation of hoist limit switches as outlined in the manual furnished with the hoist.

WARNING

NEVER OPERATE HOIST WITHOUT THE PROTECTION OF PROPERLY FUNCTIONING LIMIT SWITCHES.

6. Operate crane in both travel directions, without load on the crane, and stop motion to check operation of the crane drive motor brake. The crane should stop within a distance equal to 10% of the full load travel speed of the crane. If the crane does not stop within this distance, the crane drive motor brake requires adjustment. Refer to the CRANE MOTOR BRAKE section of this manual for instructions on motor brake adjustment.
7. Operate trolley in both travel directions, without load on the crane, and stop motion to check operation of the trolley drive motor brake. The trolley should stop within a distance equal to 10% of the full load travel speed of the trolley. If the trolley does not stop within this distance, the trolley drive motor brake requires adjustment. Refer to the CRANE MOTOR BRAKE section of this manual for instructions on motor brake adjustment, if a LOUDEN® trolley or carrier is furnished; or to the manual furnished with the hoist.

TEST

8. If travel limit switches are installed on the runway or bridge girders, operate the crane or trolley hoist to verify limit switch operation. Adjust as required.

WARNING

NEVER OPERATE CRANE WITHOUT THE PROTECTION OF PROPERLY FUNCTIONING TRAVEL LIMIT SWITCHES.

DANGER

DISCONNECT POWER AND LOCKOUT DISCONNECTING MEANS BEFORE ADJUSTING LIMIT SWITCHES. LIMIT SWITCHES SHOULD BE ADJUSTED USING A CONTINUITY TESTER OR OTHER TYPE OF TESTER THAT WILL INDICATE OPEN OR CLOSED CIRCUITS WITHOUT THE NEED OF ELECTRICAL POWER.

Only a qualified electrician should adjust switches.

9. Operate the crane, without a load on the crane, for the entire travel distance of the runway monorail to check that crane and trolley hoist do not interfere with any other items or pieces of equipment located in the path of travel.
10. If crane has a trolley hoist, operate the trolley hoist, without a load on the hoist hook, for the entire travel distance of the trolley to check that trolley, hoist, load block, and hook do not interfere with any other items or pieces of equipment located in the path of travel.
11. If crane operates in a system with interlocks or transfer sections, operate crane or trolley through all such devices to verify alinement and operation. Adjust as required.

WARNING

NEVER OPERATE CRANE WITHOUT THE PROTECTION OF PROPERLY FUNCTIONING LOCKING AND SAFETY DEVICES.

12. Crane is now ready to be load tested, if required.

LOAD TEST:

All new, altered, reinstalled, modified, or repaired cranes SHALL be load tested by the owner/user before being placed in operational service.

All hoists in which load suspension parts have been altered, replaced, or repaired SHALL be dynamically tested by the owner/user before being placed in operational service. Refer to the manual furnished with the hoist and ASME B30.16 to determine test requirements for the hoist.

The load test shall be conducted under the direction of a designated person and a record of the test should be made. The test load applied to the crane shall be not less than 100% of the rated load capacity of the crane, or greater than 125% of the rated load capacity of the crane. Functions to be performed during the load test include: (1) operation of control devices; (2) lifting and lowering; and (3) operation of brakes.

Load test steps are as follows:

1. Attach test load to the hoist hook.
2. Before lifting the load, operate the hoist in the lifting direction to take any slack out of the hoist wire rope.
3. Lift the load a few inches and stop the hoist. If brakes stop and hold the load, continue lifting and lowering the load several feet, stopping the hoist several times in each direction to check that the hoist braking system stops and holds the load.

TEST

4. If the hoist braking system stops and holds the load, the hoist operates in accordance with the control devices, and no unusual sounds are present during operation, proceed with test.
5. If the hoist braking system does not stop and hold the load, the hoist does not operate in accordance with the control devices, or any unusual sounds are present during operation, corrective action must be taken. Refer to the manual furnished with the hoist.
6. Transport the test load by means of the trolley hoist or carrier the full travel length of the trolley or carrier on the bridge girder.
7. Transport the test load by means of the crane the full travel length of the runway, in one direction with the trolley or carrier as close to the extreme right-hand end of the crane bridge girder as practical, and in the other direction with the trolley or carrier as close to the extreme left-hand end of the crane bridge girder as practical. When cranes operate on more than two runways (multiple-truck cranes), the crane shall transport the test load for the full travel length of the runway with the test load under each of the intermediate end trucks.

Upon completion of the operational and load tests, the crane is ready to be released for operating purposes.

MAINTENANCE AND REPAIR

If maintenance, adjustment, replacement of parts, or repair of the crane is required because of any damage or malfunctions noted during the daily, frequent, or periodic inspections outlined in the INSPECTION section of this manual; because of conditions found during a crane test as outlined in the TEST section of this manual; or based upon specific instructions outlined in other sections of this manual; the crane shall be taken out of service, and maintenance performed as required.

WARNING

BEFORE PERFORMING ANY MAINTENANCE OR ADJUSTMENTS ON THE CRANE, REFER TO THE MAINTENANCE AND INSPECTION PROCEDURES SECTION OF THIS MANUAL.

DANGER

HAZARDOUS VOLTAGES ARE PRESENT IN THE CONTROL BOX, OTHER ELECTRICAL COMPONENTS, AND CONNECTIONS BETWEEN THESE COMPONENTS.

The main switch (disconnect) of the crane, or lifting system shall be de-energized. Lock and tag the main switch in the de-energized position in accordance with ANSI Z244.1.

Follow the instructions outlined in various sections of this manual for specific components or portions of the crane where maintenance or adjustment is required. Refer to the parts identification pages for the specific portion of the crane where maintenance or adjustment is being performed and to identify any part numbers requiring replacement.

If any instructions are not clear; or if any additional information is required in reference to adjustment, maintenance, or identification of parts; contact Acco Chain & Lifting Products or the distributor of the crane.

LUBRICATION

All moving parts of the crane for which lubrication is specified should be inspected, checked, and lubricated on a regular basis. The method used to deliver lubricant should be checked for proper delivery of the lubricant. This section applies to LOUDEN® cranes and trolleys or carriers only. If a hoist is installed as part of a crane or lifting system, lubrication instructions covered in the manual furnished with the hoist should be followed.

Crane drive unit gear housings are enclosed and provide a liberal oil reservoir from which gears and bearings inside the housing are splash-lubricated. Check oil level in gear housings periodically, with intervals determined by use and operating conditions. Refer to INSPECTION section of this manual.

Crane machinery shall be stationary when inspecting, checking, adding or changing lubricants. The main switch (disconnect) of the crane, or lifting system shall be de-energized. Lock and tag the main switch in the de-energized position in accordance with ANSI Z244.1.

WARNING

BEFORE INSPECTING, CHECKING, ADDING, OR CHANGING LUBRICANTS OF THE CRANE, REFER TO THE MAINTENANCE AND INSPECTION PROCEDURES SECTION OF THIS MANUAL.

CAUTION

DO NOT USE LUBRICANTS THAT DO NOT MEET THE SPECIFICATIONS OF THE RECOMMENDED LUBRICANTS.

WARNING

ALL LUBRICANTS:
MAY CAUSE MILD EYE IRRITATION - AVOID CONTACT WITH EYES.
MAY CAUSE MODERATE SKIN IRRITATION - AVOID PROLONGED OR REPEATED CONTACT WITH SKIN. WASH THOROUGHLY AFTER HANDLING.
ARE SLIGHTLY COMBUSTIBLE - KEEP AWAY FROM EXTREME HEAT AND OPEN FLAME.

LUBRICATION

CRANE AND CARRIER OR TROLLEY GEAR HOUSING:

Two types of gear drive units are used on motor-driven cranes and trolleys. Refer to the instructions that apply to the type of reducer supplied with the crane or trolley. The two types of crane gear drive units are:

Model 3A107 for Center Drive Cranes with Adjustable Spring-Loaded Drive Tires

The model 3A107 crane drive unit is an enclosed gear reduction mounted off the center of bridge girder, or near one of the end trucks. Line shafts extend from each output side of the reducer unit to the adjustable spring-loaded drive tires at each end truck. This same gear reduction unit is used as a trolley or carrier with an adjustable spring-loaded drive tire and identified as the model M-9 MOTOVEYOR®. The M-9 MOTOVEYOR® is covered in Manual 69879, Installation, Operation, Maintenance, and Parts Manual for LOUDEN® Underhung Crane and Monorail Accessories. The model 3A107 crane drive unit is shown in Figure 8.

FIGURE 8

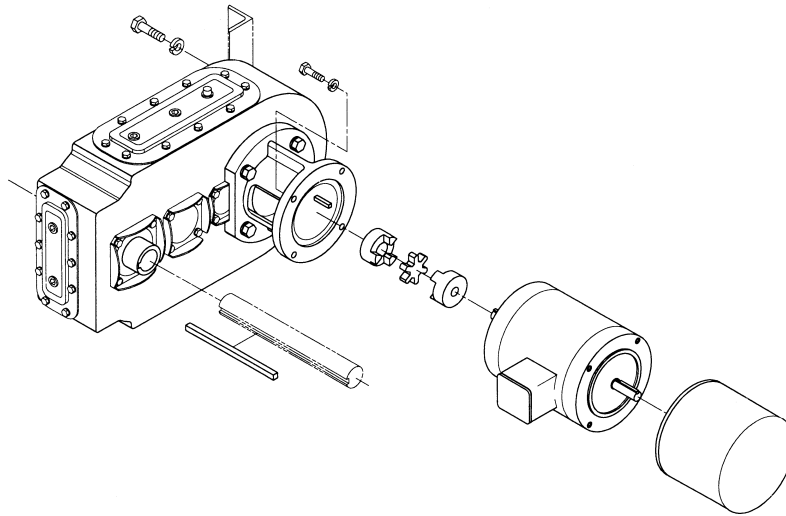

Steel-Wheel Drive for Dual-Drive and Multiple-Drive Cranes

The steel-wheel crane drive unit is an enclosed spur gear reduction unit that replaces an idler trolley on either cranes and trolleys or carriers. The final reduction is exposed and the pinions drive the wheels that travel on the monorail track. The steel-wheel drive is shown in Figure 9.

FIGURE 9

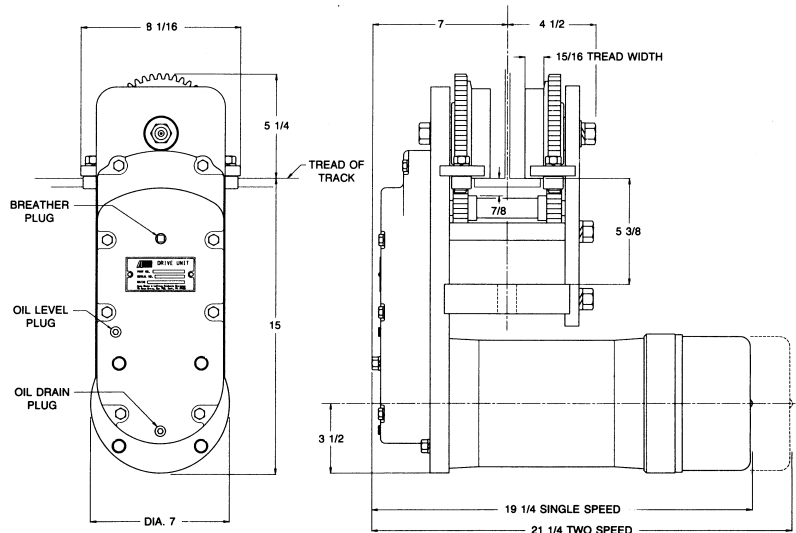

LUBRICATION

MODEL 3A107 CRANE DRIVE:

The model 3A107 crane drive unit will be positioned in different mounting positions depending on the type of crane specified. Various mounting positions are shown in Figure 10. Determine the mounting position applicable by viewing the crane and Figure 10 to see the location of breather and oil fill plug, oil level plug, and drain plug.

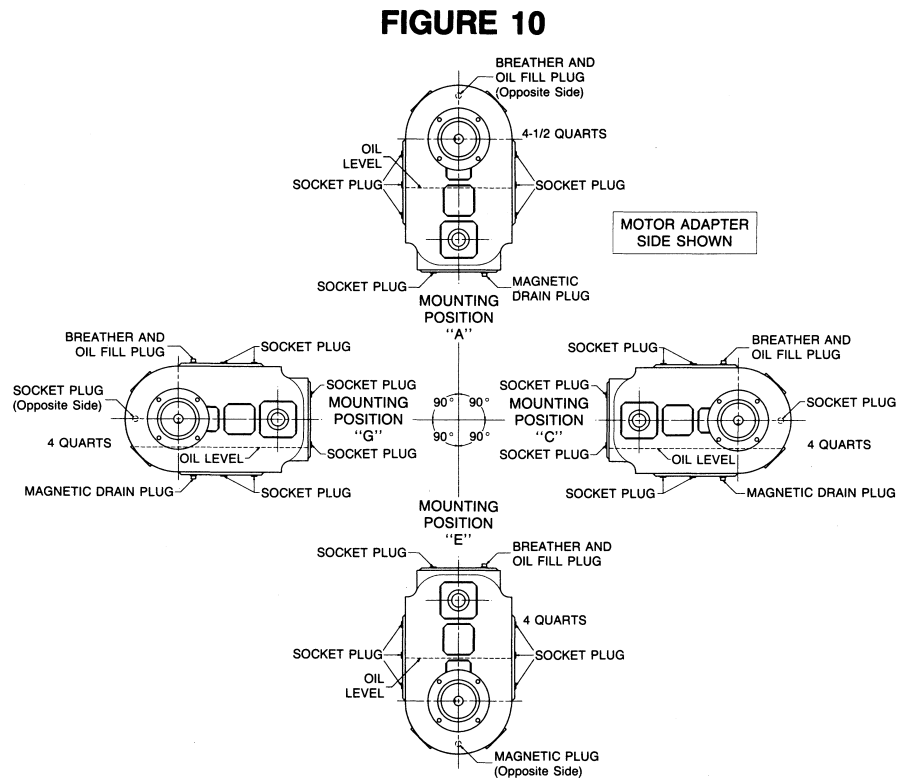

When the model 3A107 is shipped from the factory, the breather plug hole is closed by use of a solid plug. During installation, this solid plug is to be removed and replaced with a breather plug furnished loose. When installing the breather plug, the breather hole on the outside of the plug must be directed upward. During inspection, clean the breather plug and check that the breather hole in the plug is not closed because of foreign matter or dirt. If the breather hole is closed, either clean the plug to open the breather hole or replace with a new breather plug.

The level of the oil in the housing should be level with the bottom of the oil level hole. If the level of the oil in the housing is below this point, add oil. Add oil through the oil fill hole at the breather plug until oil level in the housing is level with the bottom of the oil level hole. Refer to Table 3 for recommended lubricants. AGMA stands for American Gear Manufacturers Association. Table 4 lists lubricants of some lubricant manufacturers in accordance with AGMA lubricant numbers.

**TABLE 3
GEAR HOUSING LUBRICANTS
MODEL 3A107 CRANE DRIVE UNIT
STEEL-WHEEL CRANE DRIVE UNIT**

AMBIENT TEMPERATURE	AGMA LUBRICANT
Below 15° F (-9° C)	Contact Acco
15° to 60° F (-9° to 16° C)	AGMA No. 4 EP
50° to 125° F (10° to 52° C)	AGMA No. 6 EP
Above 100° F (38° C)	Contact Acco

LUBRICATION

For normal service, replace gear housing oil after 300 operational hours or 6 months, whichever comes first. Replace oil more frequently for heavy duty service or as required. Select lubricant from Table 3. The drive is shipped from the factory with AGMA No. 6 EP oil. Remove oil from housing through the drain hole and replace plug. Add oil through the oil fill hole until oil level in the housing is level with the bottom of the oil level hole. Make sure all plugs have been replaced before operating crane.

**TABLE 4
AGMA LUBRICANTS BY MANUFACTURER**

MANUFACTURER	AGMA 4EP	AGMA 6EP	AGMA 7 COMP.	AGMA 8 COMP.
Amoco Oil Co.	Perma Gear EP 150	Perma Gear EP 320	Worm Gear Oil	Cylinder Oil 680
ARCO	Pennant NL Oil 150	Pennant NL Oil 320	Modoc 175	Modoc 175
Chevron USA, Inc.	Gear Compound EP Grade 150	Gear Compound EP Grade 320	Cylinder Oil 460X	Cylinder Oil 680X
Conoco	Gear Oil Grade 150	Gear Oil Grade 320	none	none
Exxon Co. USA	Spartan EP Grade 150	Spartan EP Grade 320	Cylestic TK-460	Cylestic TK-680
Gulf Oil Co.	EP Lubricant HD 150	EP Lubricant HD 320	Senate 460	Senate 680D
Mobil Oil Corp.	Mobilgear 629	Mobilgear 632	600W Super	Extra Hecia Super
Shell Oil Co.	Omala 150	Omala 320	Valvata Oil J460	Valvata Oil J680
Sun Oil Co.	Sun EP 1060	Sun EP 1090	Gear Oil 7C	Gear Oil 8C
Texaco	Meropa 150	Meropa 320	Honor Cylinder Oil 460	650T Cylinder Oil
ISO Viscosity Grade	150	320	460	680
Ambient Temperature	15° to 60° F -9° to 16° C	50° to 125° F 10° to 52°	C15° to 60° F -9° to 16° C	50° to 125° F 10° to 52° C

STEEL-WHEEL CRANE DRIVE:

Refer to Figure 9 to determine the location of breather and oil fill plug, oil level plug, and drain plug for the steel-wheel crane drive unit.

When the steel-wheel drive is shipped from the factory, the breather plug hole is closed by use of a solid plug. During installation, this solid plug is to be removed and replaced with a breather plug furnished loose. When installing the breather plug, the breather hole on the outside of the plug must be directed upward. During inspection, clean the breather plug and check that the breather hole in the plug is not closed because of foreign matter or dirt. If the breather hole is closed, either clean the plug to open the breather hole or replace with a new breather plug.

The level of the oil in the housing should be level with the bottom of the oil level hole. If the level of the oil in the housing is below this point, add oil. Add oil through the oil fill hole at the breather plug until oil level in the housing is level with the bottom of the oil level hole. Refer to Table 3 for recommended lubricants. AGMA stands for American Gear Manufacturers Association. Table 4 lists lubricants of some lubricant manufacturers in accordance with AGMA lubricant numbers.

For normal service, replace gear housing oil after 300 operational hours or 6 months, whichever comes first. Replace oil more frequently for heavy duty service or as required. Select lubricant from Table 3. The drive is shipped from the factory with AGMA No. 6 EP oil. Remove oil from housing through the drain hole and replace plug. Add oil through the oil fill hole until oil level in the housing is level with the bottom of the oil level hole. Make sure all plugs have been replaced before operating crane.

LUBRICATION

BEARINGS:

Bearings not located inside gear housing and motor are pre-lubricated and provided with shields or seals, unless provided with lube fittings, for operation in ambient temperatures between 0°F and 104°F, and in environments reasonably free from dust, moisture, and corrosive fumes. No additional lubricant is required for bearings with shields or seals. If bearings are provided with lube fittings, check and add NLGI No. 2 grease every 6 months. For other operating conditions, contact Acco Chain & Lifting Products or the distributor of the crane.

WHEEL BEARINGS:

Unless provided with lube fittings, wheel bearings are pre-lubricated and provided with shields or seals for operation in ambient temperatures between 0°F and 104°F, and in environments reasonably free from dust, moisture, and corrosive fumes. No additional lubricant is required for wheel bearings with shields or seals. If wheel bearings are provided with lube fittings, check and add NLGI No. 2 grease every 6 months. For other operating conditions, contact Acco Chain & Lifting Products or the distributor of the crane.

BRONZE THRUST WASHERS:

Inspect and check bronze thrust washers every 6 months. Clean the old lubricant off the bronze thrust washer. If washer shows signs of cracks or excessive wear (washer thickness worn to 75% of original thickness), replace bronze thrust washer. Bronze washers are to be coated with Lubriplate 630-AA or 630-2 before re-installing.

EXPOSED OR OPEN GEARS AND PINIONS:

Exposed gears and pinions on steel-wheel drives are shipped from the factory without lubricant. Lyondell® EP Moly D Grease, packaged in a 4-ounce squeeze bottle container, is furnished with all steel-wheel drives. During installation, the Lyondell® EP Moly D Grease should be applied to all exposed gears and pinions so that a coating of lubricant is on all pinion and gear teeth.

For normal service, apply Lyondell® EP Moly D Grease or equivalent to all exposed gears and pinions every 3 months to maintain a coating of lubricant on all pinion and gear teeth. Apply grease more frequently for heavy duty service or as required.

In applications where foreign matter or dirt combines with the grease on exposed gears and pinions, the dirty grease should be cleaned off the teeth prior to applying new grease.

Additional containers of Lyondell® EP Moly D Grease, packaged in a 4-ounce squeeze bottle, can be obtained by ordering Acco® part no. 69807.

WARNING

NEVER APPLY ANY LUBRICANTS TO PARTS OF THE CRANE DRIVE MOTOR BRAKE.

CRANE DRIVE BRAKE

Motor brakes are standard on motor-driven crane drive units.

The brake coil on reconnectable 230/460 volt single-speed motors may be connected for 230 volts or 460 volts. The brake coil must be reconnected as shown in Figure 11 if the motor voltage is reconnected.

FIGURE 11

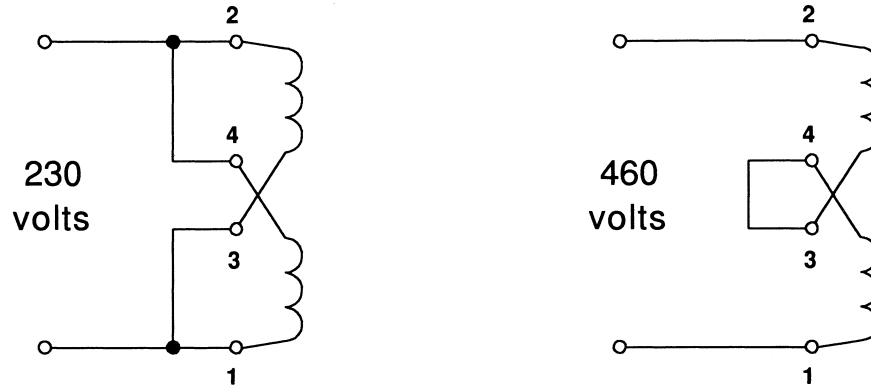

Crane drive brake on cranes in regular service should be checked without load on the crane by the operator at the start of each shift, or the first time the crane is to be operated during each shift. The crane drive brake should be checked during scheduled frequent and periodic inspections.

During daily, frequent, or periodic inspections, the crane drive brake should be checked as follows:

1. Operate crane in both travel directions, without load on the hook, and stop motion to check operation of the crane drive brake. The drift of the crane should not exceed a distance equal to 10% of the crane travel speed in either direction. If crane drift exceeds this distance, the crane drive brake normally requires adjustment or lining replacement.
2. After completing crane drive brake adjustment or lining replacement, operate crane in both travel directions, without load on the hook, and stop motion to check operation of the crane drive brake. If crane drift is still excessive, replace the brake assembly.

⚠ DANGER

DISCONNECT POWER AND LOCKOUT DISCONNECTING MEANS BEFORE ADJUSTING CRANE DRIVE BRAKE.

Only qualified personnel should adjust brakes.

FIGURE 12

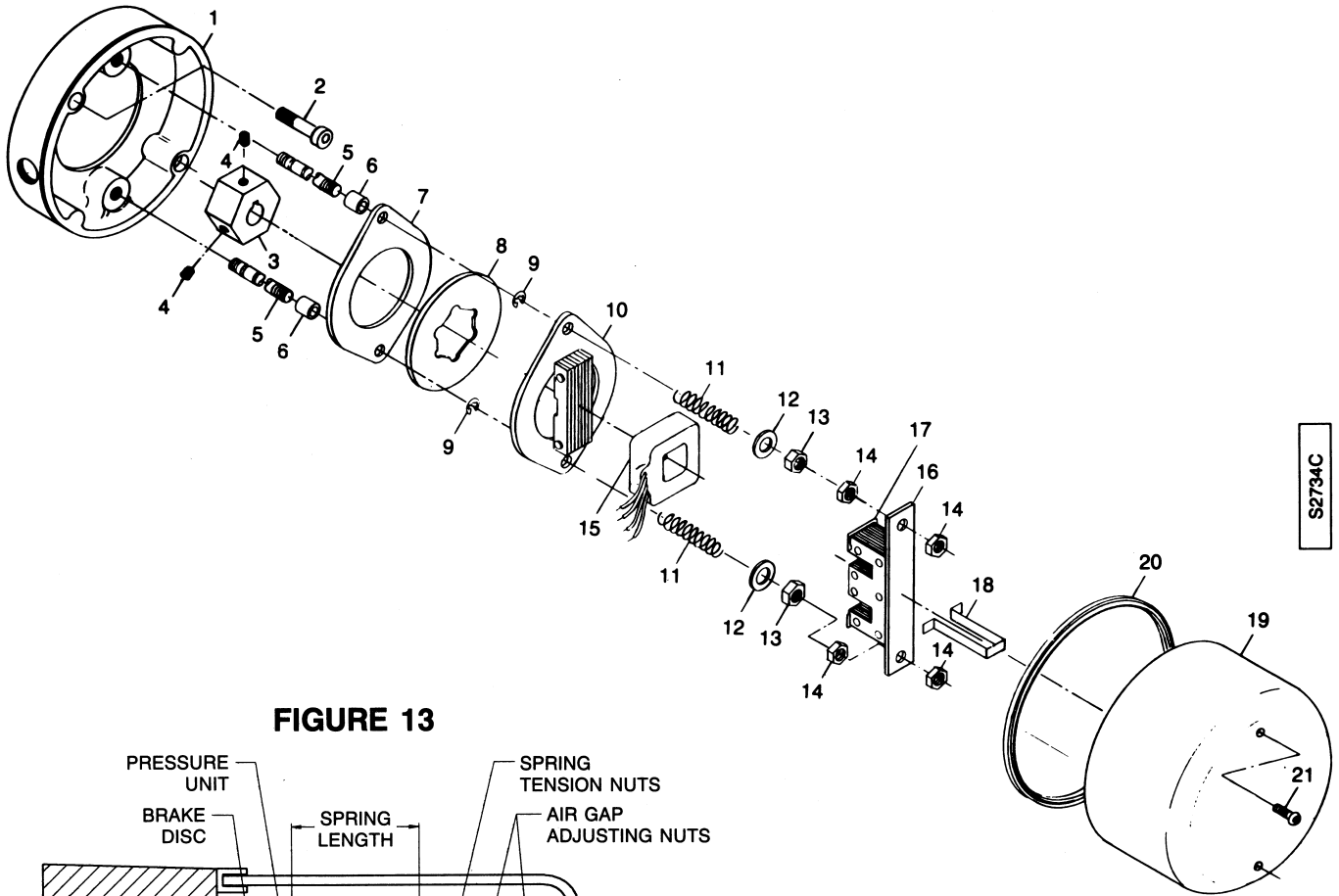
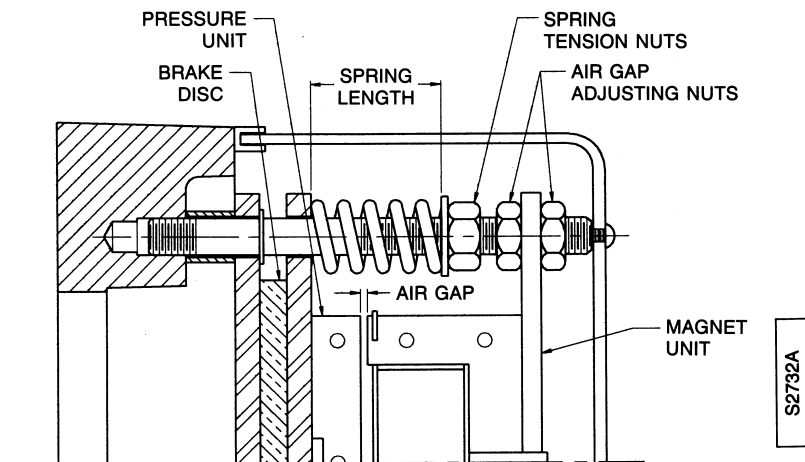

FIGURE 13



CRANE DRIVE BRAKE INSPECTION:

The crane drive brake and parts are shown in Figures 12 and 13. Crane drive motor brake should be inspected every three months, and during scheduled frequent and periodic inspections, as follows:

1. Follow the procedures and instructions listed in the MAINTENANCE AND INSPECTION PROCEDURES section of this manual.
2. Loosen and remove bolts (21) securing brake cover (19).
3. Remove brake cover (19).
4. Use air or brush to remove any lining dust that has accumulated on brake parts. Specific attention should be directed to removal of dust from the air gap between magnet (17) and armature plate (10).

CRANE DRIVE BRAKE

⚠ WARNING

USE PROPER EYE AND BREATHING PROTECTION EQUIPMENT DURING DUST REMOVAL.

5. Check brake coil (15) for proper fit and retention in magnet (17). Adjust coil strap (18) to tighten.
6. Check for loose electrical connections or broken wires. Repair or replace as required.
7. Check thickness of brake disc (8). Replace disc if worn to a thickness of 3/32 inch (2.4 mm) or less.
8. Check air gap and adjust if required. Minimum air gap - 0.020 inch (0.5 mm) Maximum air gap - 0.045 inch (1.1 mm) Adjust in accordance with "TO ADJUST AIR GAP" instructions of this section.
9. Replace brake cover (19) and secure with bolts (21). Bolts (21) are self-locking type with locking insert. Do not reuse bolts with damaged locking insert or that do not tighten properly. When replacing the brake cover, the ends of the rubber gasket should face downward to prevent water or foreign substances from getting inside the brake cover.

TO ADJUST AIR GAP:

Adjust crane drive brake air gap as follows:

1. Loosen the air gap adjusting nuts (14) to allow the magnet unit (16) to move toward the pressure unit (10). Using a feeler gage, set the air gap to 0.020 inches. Tighten air gap adjusting nuts (14) to lock the position on the magnet unit (16). Check air gap at several points to verify uniform setting.
2. As brake disc wear occurs, the compressed length of spring (11) will increase. Select the recommended compressed spring length from Table 5, based on crane motor horsepower. Adjust both spring lengths in accordance with Table 5. If crane stopping performance is not satisfactory, increase compressed spring length for less brake torque or decrease compressed spring length for more brake torque.

**TABLE 5
COMPRESSED LENGTH OF SPRING
CRANE DRIVE MOTOR BRAKE**

MOTOR HORSEPOWER 1800 RPM	BRAKE TORQUE (LB FT)	COMPRESSED LENGTH SPRING (IN)
1/2	3/4	1-5/8
3/4	1-1/8	1-9/16
1	1-1/2	1-1/2
1-1/2	2-1/4	1-3/8
2	3	1-1/4
3	4-1/2	1-1/2
5	7-1/2	1-5/16
MOTOR HORSEPOWER 1200 RPM	BRAKE TORQUE (LB FT)	COMPRESSED LENGTH SPRING (IN)
1/2	1-1/8	1-9/16
3/4	1-3/4	1-7/16
1	2-1/4	1-3/8

END TRUCKS AND WHEELS

END TRUCK AND WHEEL INSPECTION:

Crane end trucks and wheels should be inspected every three months, and during scheduled frequent and periodic inspections, as follows:

1. Follow the procedures and instructions listed in the MAINTENANCE AND INSPECTION PROCEDURES section of this manual.
2. Inspect crane wheel bearings for wear by manually rotating and rocking wheels. If excessive bearing play is present, replace bearings.
3. Inspect for wear, flat spots, or damage to wheel tread; and cracked or broken wheel flanges. Replace wheels as required. When wheel replacement is required, all the wheels of a crane should be replaced.
4. Inspect gear teeth of geared wheels and pinion for wear, cracks, or damage. Replace geared wheels or pinion as required. Geared wheels should always be replaced in pairs.
5. Inspect and tighten or replace as required all bolts, nuts, and locking devices on the endtruck.
6. Inspect and tighten or replace as required all bolts, nuts, and locking devices connecting bridge girder or girders, trusses, braces, and other structural members to the endtrucks.
7. Inspect bronze thrust washers for cracks and excessive wear. Refer to LUBRICATION section of this manual.
8. Check lubrication in accordance with the LUBRICATION section of this manual.

ELECTRICAL COMPONENTS

⚡ DANGER

HAZARDOUS VOLTAGES PRESENT.

DISCONNECT POWER AND LOCKOUT DISCONNECTING MEANS BEFORE INSPECTING OR SERVICING.

Only qualified electricians should inspect, service, repair, or replace electrical components.

ELECTRICAL COMPONENTS INSPECTION:

Electrical components should be inspected every three months, and during scheduled frequent and periodic inspections, as follows:

1. Follow the procedures and instructions listed in the MAINTENANCE AND INSPECTION PROCEDURES section of this manual.
2. Components to examine:
 - a. Magnetic contactors.
 - b. If provided, travel limit switches, and locking devices.
 - c. Control devices.
 - d. Wiring and connections.
3. Damage to look for:
 - a. Pitting.
 - b. Corrosion.
 - c. Broken parts.
 - d. Damage and deterioration of any kind.
 - e. Damaged or frayed wire.
 - f. Loose terminal connections.
4. Corrective action required:
 - a. Tighten any loose connections.
 - b. Replace any damaged or frayed wires.
 - c. Replace any pitted, burned, or corroded contacts or the entire contactor. Replace contacts in sets only. NEVER attempt to smooth contacts by filing or other means.
 - d. Replace damaged components.
 - e. Lubricate controller parts only if recommended by the controller manufacturer.

RECONNECTABLE MOTORS:

Standard crane drive single-speed motors are reconnectable for 208/230 volt or 460 volt, three-phase, 60 Hz. operation. Such motors and control will be connected at the factory for 460 volt unless otherwise specified. All two-speed motors, 200 volt single-speed motors, and 575 volt single-speed motors are single voltage motors, and are not reconnectable.

ELECTRICAL COMPONENTS

If reconnection of a 230/460 volt motor is required, proceed as follows:

1. If crane is connected to the main power supply, de-energize, lock, and tag the main switch (disconnect).
2. Reconnect the control circuit transformer, located inside the control enclosure. Connection instructions are located on the transformer. Refer to Table 8 and Figure 17.
3. Reconnect the crane drive motor leads inside the motor junction box. Refer to Table 6 and Figures 14 and 15.
4. Reconnect the crane drive motor brake leads inside the motor junction box. Refer to Table 9 and Figure 18. Refer to the CRANE DRIVE BRAKE section of this manual for additional crane drive brake information.
5. If the crane is equipped with optional motor circuit fuses or overload relays sized for the original connection voltage, they must be replaced with ones properly sized for the reconnected voltage.

CAUTION

WHEN RECONNECTING FOR A DIFFERENT VOLTAGE, MOTOR CIRCUIT FUSES AND THERMAL OVERLOADS (IF ANY) MUST BE REPLACED WITH UNITS THAT COMPLY WITH THE NEW VOLTAGE AND CURRENT RATINGS.

WARNING

WHENEVER ANY CHANGES HAVE BEEN MADE, DO NOT OPERATE CRANE OR HOIST UNTIL ALL SAFETY DEVICES HAVE BEEN RECHECKED IN THE SAME MANNER AS DURING ORIGINAL INSTALLATION. REFER TO INSTALLATION SECTION OF THIS MANUAL.

Refer to Table 7 and Figure 16 for two-speed motor connections.

FIGURE 14

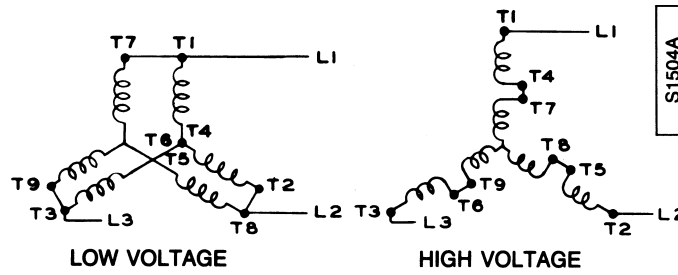

FIGURE 15

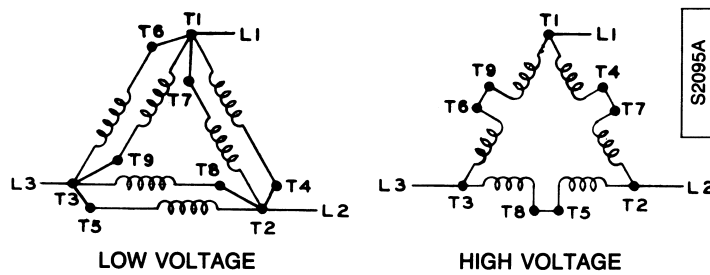

FIGURE 16

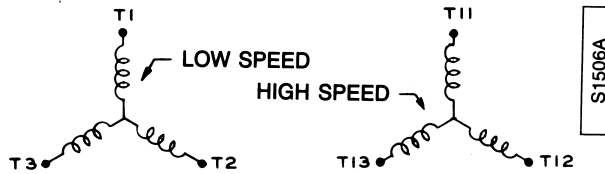

FIGURE 17

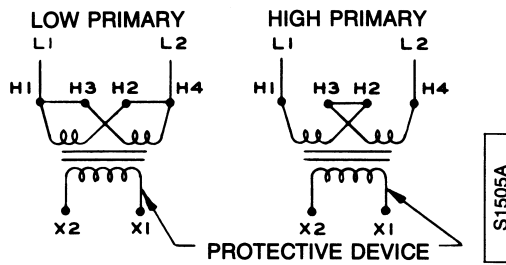
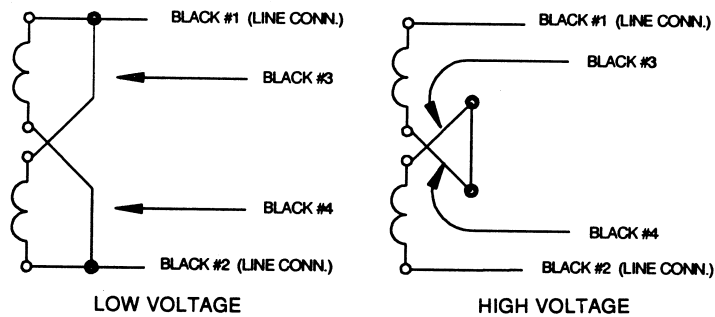

FIGURE 18



ELECTRICAL COMPONENTS

**TABLE 6
MOTOR CONNECTIONS
Y-CONNECTED (Figure 14) DELTA-CONNECTED (Figure 15)**

LOW VOLTAGE	HIGH VOLTAGE	LOW VOLTAGE	HIGH VOLTAGE
L1,T1,T7	L1,T1	L1,T1,T6,T7	L1,T1
L2,T2,T8	L2,T2	L2,T2,T4,T8	L2,T2
L3,T3,T9	L3,T3	L3,T3,T5,T9	L3,T3
	T4,T7		T4,T7
T4,T5,T6	T5,T8		T5,T8
	T6,T9		T6,T9

**TABLE 7
TWO-SPEED MOTOR CONNECTIONS
(Figure 16)**

LOW SPEED	HIGH SPEED
L1,T1	L1,T11
L2,T2	L2,T12
L3,T3	L3,T13
INSULATE SEPARATELY	INSULATE SEPARATELY
T11-T12-T13	T1-T2-T3

**TABLE 8
TRANSFORMER CONNECTIONS
(Figure 17)**

LOW VOLTAGE	HIGH VOLTAGE
H1,H3-L1	H1-L1
H2,H4-L2	H4-L2
	H2-H3

**TABLE 9
CRANE DRIVE MOTOR BRAKE COIL CONNECTIONS**

VOLTAGE	BRAKE COIL PART NO. 39783-3
230 VAC	Figure 18, Low voltage
380 VAC	Figure 18, High voltage
480 VAC	Figure 18, High voltage

NOTICE

When a hoist is installed on a crane system that requires a common control voltage between the crane and hoist controls, the following must be adhered to:

1. Primary phasing to the control transformer in both the hoist and crane must be identical.
2. X1 must be connected between the hoist and crane controls.
3. The X2 secondary leads **MUST NOT** be connected together or to ground.

FAILURE TO FOLLOW THESE GUIDELINES WILL RESULT IN MISMATCHED VOLTAGES AND BLOWN CONTROL TRANSFORMER FUSES.

On installations where a grounded X2 secondary is required, SEPARATE X1 leads must be used for:

1. the mainline contactor (on the crane) and crane motion, and
2. the trolley/hoist motion controls or push buttons.

The X1 of transformers with grounded X2 secondaries **MUST NOT** be tied together.

If additional information is required, contact Acco Chain & Lifting Products or the distributor of the hoist.

ACCELERATION CONTROL MODULE V

An Acceleration Control Module V (ACM V) is furnished as a standard feature on all power-driven cranes using a three-phase electric motor. The ACM V is a solid state device designed to provide reduced starting torque and controlled acceleration of three-phase motors. The ACM V offers a soft controlled start that reduces the swinging action of suspended loads caused by uncontrolled abrupt starts. Starting torque and acceleration rate can be adjusted to accommodate differing requirements.

DANGER

HAZARDOUS VOLTAGES ARE PRESENT IN THE CONTROL BOX, OTHER ELECTRICAL COMPONENTS, AND CONNECTIONS BETWEEN THESE COMPONENTS.

The main switch (disconnect) of the hoist, crane, or lifting system shall be de-energized. Lock and tag the main switch in the de-energized position in accordance with ANSI Z244.1.

Only qualified electricians should inspect, adjust, service, repair, or replace electrical components.

All adjustments of ACM V must be made with the main switch locked and tagged in the de-energized position. After adjustments are made, re-energize power supply and test operation of ACM V. If additional adjustment is required, repeat this procedure.

NOTICE

Multi-Voltage Controls must be set for correct voltage before operating.

ACM V SINGLE SPEED ADJUSTMENT:

1. Set the TIME adjustment at the maximum point and the INITIAL TORQUE adjustment at the minimum point. (This initial setting provides the softest start, but the initial torque may be too small to start the motor for the first few cycles.)
2. Set the INITIAL TORQUE adjustment first; usually $\frac{1}{4}$ to $\frac{1}{2}$ of a turn from the minimum torque setting is adequate.
3. Decrease the TIME adjustment if the starting is too soft under a half load condition. Strive for a smooth even transition from zero to maximum speed with a minimal INITIAL TORQUE setting.

ACM V TWO SPEED ADJUSTMENT:

1. Set the TIME adjustment at the maximum point and the ACCELERATION and DECELERATION INITIAL TORQUE adjustments at the minimum points. (This setting provides the softest start, but the initial torque may be too small to start the motor for the first few cycles.)
2. Set the ACCELERATION TORQUE adjustment first; usually $\frac{1}{4}$ to $\frac{1}{2}$ of a turn from the minimum torque setting is adequate.
3. Next set the DECELERATION TORQUE adjustment by turning it to the minimum torque setting. If the transition from high to low speed is too soft, increase the setting until an appropriate transition is obtained. Usually setting the DECELERATION TORQUE adjustment to minimum proves to be the best setting.

DANGER

SERVICE CHECKS OF THE ACM V REQUIRE THAT THE ELECTRICAL POWER SUPPLY BE ENERGIZED.

THEREFORE, only electricians qualified and certified to work on energized circuits and equipment should perform this service.

ACCELERATION CONTROL MODULE V

NOTICE

All readings should be taken with a standard analog type VOM (volt-ohm-meter)

ACM V SINGLE SPEED SERVICE:

1. Disconnect motor from T1, T2, and T3.
2. Set INITIAL TORQUE adjustment to minimum and the TIME adjustment to maximum.
3. Energize the contactor. For proper operation the following readings should be taken (example is for a 460 VAC, three-phase system with 115 VAC control voltage):
 - a. TL1 to TL2, TL2 to TL3, and TL1 to TL3 – 460 VAC.
 - b. Control signal point A and B terminals – 115 VAC. It is important that this reading be taken **across the A and B terminal screws on the ACM unit**. If no voltage can be read across these two points, first check for misplacement of an electrical interlock from the reversing or two-speed contactor. The “common” side of the control signal is sensed through the coil which is not *energized*, so do not interlock the common wire out of the circuit. Simply checking for 115 VAC from one screw terminal and the “common” wire is NOT sufficient. Without a proper signal to the A and B terminals (and the HI, LO, and COMMON on two-speed models), the output of the ACM at T1, T2, and T3 will remain zero (0) VAC. A and B must only be connected to the contactor coils, **NEVER THE CONTROL TRANSFORMER**.
 - c. After six seconds, take readings at T1, T2, and T3 (with the motor disconnected).
 - (1) From T1 to T2, T2 to T3, and T1 to T3, the voltage is approximately 80-95% of line voltage. For the 460 VAC ACM, the reading is approximately 405 VAC.
 - (2) A zero (0) VAC output will occur if the proper control signal is not being received (See b above and a, b, and c listed under two-speed service).
 - d. With the TORQUE adjustment at minimum and the TIME adjustment at maximum, take a meter reading across terminals T1, T2, and T3 (as in c(1) above), from the instant the contactor is closed. The meter should move slowly during the first five seconds, then quickly for the last second. The total time to reach 88% of the line voltage should be approximately six to nine seconds. Each phase to phase test should be similar in voltage profile, no matter where the TIME and TORQUE adjustments are set. Due to the dampening factor in volt-ohm-meters, it is difficult to detect the exact voltage level at a particular torque setting. However, the varying of the TORQUE and TIME settings can be readily identified on the meter. **THE IMPORTANT POINT IS THAT ALL THREE VOLTAGE PROFILES ARE THE SAME.**

ACM V TWO SPEED SERVICE:

Steps 1, 2, and 3 are the same as for single-speed control. The difference lies with the control signal circuitry. For proper operation, check the following control signals across the screws on the ACM. See 3b of single-speed service for general testing procedure.

- a. When the contactor is energized for low speed operation, the meter will read:
 - (1) Between HI and COMMON 0 VAC
 - (2) Between LO and COMMON 115 VAC
 - (3) Between LO and HI 115 VAC
 - (4) Between A and B 115 VAC
- b. When the contactor is energized for high speed operation, the meter will read:
 - (1) Between HI and COMMON 115 VAC
 - (2) Between LO and COMMON 0 VAC
 - (3) Between LO and HI 115 VAC
 - (4) Between A and B 115 VAC
- c. If another control voltage is used, it will appear instead of the 115 VAC listed above.

TROUBLESHOOTING

If crane operates erratically, or not at all, the crane should be taken out of service. Any problem should be diagnosed and corrected before the crane is returned to regular service. Refer to Table 10 for some problem areas to consider and investigate.



DISCONNECT POWER AND LOCKOUT DISCONNECTING MEANS BEFORE PERFORMING SERVICE TO ELECTRICAL PARTS OF THIS EQUIPMENT.

Only a qualified electrician should perform service to electrical parts of this equipment.

TABLE 10

PROBLEM	POSSIBLE CAUSE	CORRECTIVE ACTION
Crane will not operate.	Power failure in power lines.	Check circuit breakers, switches, and connections in power lines.
	Low voltage or frequency.	Check voltage and frequency, or power supply. They must agree with data on nameplate.
	Motor overheated. (Thermostat or thermal overload relays have tripped.	Refer to motor or brake overheating problem area. Check thermostat or thermal overloads.
	Improper, loose, or broken wire connection.	Check connections and lead wires. Check connections in control devices.
	Brake does not release.	Check connections to magnet coil. Check for open or short circuit.
	Magnetic contactor not operating.	Check coil for open or short circuit. Check all connections in control circuit. Check for open contact. Replace as needed.
	Control transformer damaged.	Check transformer fuse. Check transformer coil. Check transformer for open winding.
Crane moves in wrong direction.	Motor burned out.	Replace motor.
	Reverse phasing.	Interchange any two power supply line leads.
Crane travels in only one direction.	Improper electrical connections.	Check all connections with wiring diagram.
	One circuit open.	Check circuit for loose connections.
	Broken conductor in pendant cable.	Check continuity of each conductor in the cable. If one is broken, replace cable.
	Magnetic contactor not operating.	Check coil for open or short circuit. Check all connections in motor circuit. Check for burned contacts. Replace as needed.

TROUBLESHOOTING

TABLE 10 (CONTINUED)

PROBLEM	POSSIBLE CAUSE	CORRECTIVE ACTION
Crane will not travel with rated load or does not have proper travel speed.	<p>Crane overloaded.</p> <p>Low voltage.</p> <p>Crane drive motor brake dragging.</p> <p>ACM requires adjustment.</p>	<p>Reduce load to within rated capacity of crane.</p> <p>Determine cause of low voltage and correct to within 10% of specified name plate voltage. Measure voltage at crane contactor.</p> <p>Check crane drive motor brake adjustment for proper clearance and magnet mounting for proper location and tightness.</p> <p>Adjust as outlined in ACM V section of this manual.</p>
Crane drifts excessively when crane is stopped.	Crane drive motor brake not holding.	Inspect and check crane drive motor brake as outlined in CRANE DRIVE MOTOR BRAKE section of this manual.
Crane drive motor brake chatters or hums.	Magnet faces not clean or broken shading coil on magnet.	Clean magnet surface and replace shading coils if broken.
Crane does not track on beam or bumps as it travels on beam.	Excessive wear of crane wheel treads or flat spots on crane wheel treads.	Inspect crane wheels and replace as necessary.
Crane motor or motor brake overheating.	<p>Crane overloaded.</p> <p>Excessive duty cycle.</p> <p>Wrong voltage or frequency.</p> <p>Crane drive motor brake dragging.</p> <p>Extreme external heating.</p>	<p>Reduce load to within rated capacity of crane.</p> <p>Reduce frequency of operation.</p> <p>Check voltage and frequency, of power supply. They must agree with data on nameplate.</p> <p>Check motor brake adjustment for proper clearance and magnet mounting for proper locatin and tightness.</p> <p>If ambient temperature exceeds 100° F, frequency of crane operation must be limited to avoid overheating. Special provisions may be required to ventilate the crane drive unit or shield it from the heat source.</p>
Crane operates intermittently.	<p>Poor collector contact.</p> <p>Broken wires.</p> <p>Worn contacts.</p>	<p>Check for dirt or foreign matter on, and wear of contact surfaces. Clean or replace as necessary.</p> <p>Check wiring. Replace any broken wires.</p> <p>Locate and replace worn or burnt contacts.</p>
Oil leaks.	<p>Worn or damaged gaskets and/or oil seals.</p> <p>Joints not tight. Tighten bolts to recommended torque.</p>	Replace worn or damaged parts.

TYPICAL BRIDGE INTERCONNECTION DIAGRAM

TYPICAL BRIDGE INTERCONNECTION DIAGRAM WHEN THE PENDANT STATION IS SUSPENDED FROM THE HOIST.

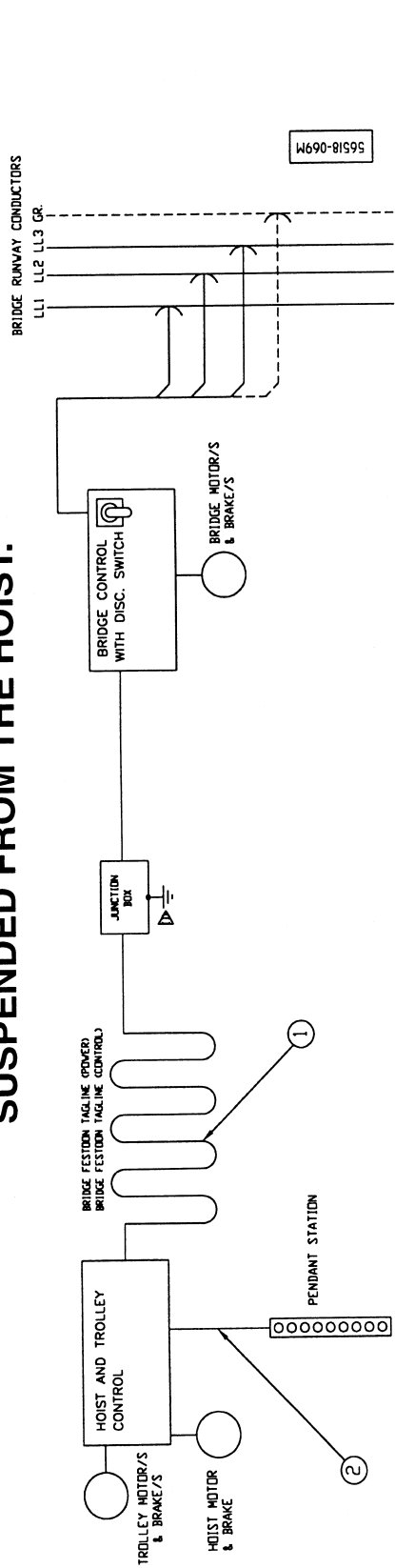

WIRE	DESCRIPTION
10	HOIST UP
11	HOIST DOWN
12	HOIST 2ND SPEED
(13)	HOIST 3RD SPEED
(14)	HOIST 4TH SPEED
(15)	HOIST 5TH SPEED
20	TROLLEY RIGHT
21	TROLLEY LEFT
22	TROLLEY 2ND SPEED
(23)	TROLLEY 3RD SPEED
(24)	TROLLEY 4TH SPEED
(25)	TROLLEY 5TH SPEED
30	BRIDGE FORWARD
31	BRIDGE REVERSE
32	BRIDGE 2ND SPEED
(33)	BRIDGE 3RD SPEED
(34)	BRIDGE 4TH SPEED
(35)	BRIDGE 5TH SPEED
40	MAINLINE ON
41	MAINLINE OFF

WIRE GROUP	SINGLE SPEED BRIDGE WITH:		MULTI-SPEED BRIDGE WITH:	
	SINGLE-SPEED HOIST	MULTI-SPEED TROLLEY	SINGLE-SPEED TROLLEY	MULTI-SPEED HOIST
1	X1, 30, 31, 40, 41, GR.	L1, L2, L3, GR.	X1, 30, 31, 40, 41, GR.	X1, 30, 31, 40, 41, GR.
2	X1, GR., 10, 11, 20, 21, 22, (23), (24), (25), 30, 31, 40, 41	X1, GR., 10, 11, 12, (13), (14), (15), 20, 21, 30, 31, 40, 41	L1, L2, L3, GR.	L1, L2, L3, GR.
WIRE GROUP	SINGLE-SPEED HOIST		MULTI-SPEED HOIST	
	SINGLE-SPEED TROLLEY	MULTI-SPEED TROLLEY	SINGLE-SPEED TROLLEY	MULTI-SPEED TROLLEY
1	X1, 30, 31, 32, (33), (34), (35), 40, 41, GR.	L1, L2, L3, GR.	X1, 30, 31, 32, (33), (34), (35), 40, 41, GR.	X1, 30, 31, 32, (33), (34), (35), 40, 41, GR.
2	X1, GR., 10, 11, 20, 21, 30, 31, 32, (33), (34), (35), 40, 41	X1, GR., 10, 11, 12, (13), (14), (15), 20, 21, 30, 31, 32, (33), (34), (35), 40, 41	L1, L2, L3, GR.	L1, L2, L3, GR.

NOTE:
 BOND ALL GROUNDING CONDUCTORS TO METALLIC JUNCTION BOXES OR CONTROL PANEL GROUNDING TERMINAL.
 CONDUCTOR SIZE MUST BE IN ACCORDANCE WITH SECTION 610 OF ANS/NFPA 70 (NATIONAL ELECTRICAL CODE) OR SECTION 40 OF THE CANADIAN ELECTRICAL CODE.
 REFERENCE CHART LISTED ON THE DRAWING TO IDENTIFY CONDUCTOR NUMBER/FUNCTION.
 WHEN VARIABLE FREQUENCY INVERTER DRIVES ARE USED TO CONTROL ANY MOTION, POWER AND CONTROL CONDUCTORS MUST BE KEPT SEPARATE INSIDE OF CONTROL PANELS AND ROUTED THROUGH SEPARATE CONDUITS ON THE EQUIPMENT.
 "MULTI-SPEED" IN THE CHART MATRIX INCLUDES CONDUCTOR REQUIREMENT INFORMATION FOR TWO-SPEED, TWO-STEP INFINITELY VARIABLE SPEED, THREE-SPEED, THREE-STEP INFINITELY VARIABLE SPEED, FOUR-SPEED AND FIVE-SPEED MOTION CONNECTIONS.

FOR TWO-SPEED OR TWO-STEP INFINITELY VARIABLE SPEED OPERATION, PROVIDE ALL CONDUCTORS NOT LISTED IN PARENTHESIS IN THE MULTI-SPEED MATRIX BLOCK.
 FOR THREE-SPEED OR THREE-STEP INFINITELY VARIABLE SPEED OPERATION, CONDUCTOR NUMBERS (13)-HOIST, (23)-TROLLEY AND/OR (33)-BRIDGE ARE ADDED TO THE TWO-SPEED CONDUCTORS.
 FOR FOUR-SPEED OPERATION, CONDUCTOR NUMBERS (14)-HOIST, (24)-TROLLEY AND/OR (34)-BRIDGE ARE ADDED TO THE CONDUCTOR REQUIREMENT FOR THREE-SPEED OPERATION.
 FOR FIVE-SPEED OPERATION, CONDUCTOR NUMBERS (15)-HOIST, (25)-TROLLEY AND/OR (35)-BRIDGE ARE ADDED TO THE CONDUCTOR REQUIREMENT FOR FOUR-SPEED OPERATION.
 X1'S FROM ALL CONTROL TRANSFORMERS ARE CONNECTED TOGETHER, UNLESS X2'S ARE GROUNDDED.

⚡ DANGER
 DISCONNECT POWER AND LOCKOUT/TAGOUT COVER OR SERVICING THIS EQUIPMENT.
 SERVICE SHOULD BE PERFORMED ONLY BY A QUALIFIED ELECTRICIAN.
 DO NOT OPERATE WITHOUT COVER IN PLACE.

⚠ CAUTION
 WIRING DIAGRAMS SHOWN ARE "TYPICAL" AND MAY NOT INCLUDE ALL DEVICES SUPPLIED WITH A PARTICULAR CONTROL. ALWAYS REFER TO THE WIRING DIAGRAM PROVIDED INSIDE OF THE CONTROL ENCLOSURE COVER OF A SPECIFIC PIECE OF EQUIPMENT, BEFORE PERFORMING ANY SERVICE.

TYPICAL BRIDGE INTERCONNECTION DIAGRAM

TYPICAL BRIDGE INTERCONNECTION DIAGRAM WHEN THE PENDANT STATION IS SUSPENDED FROM THE BRIDGE.

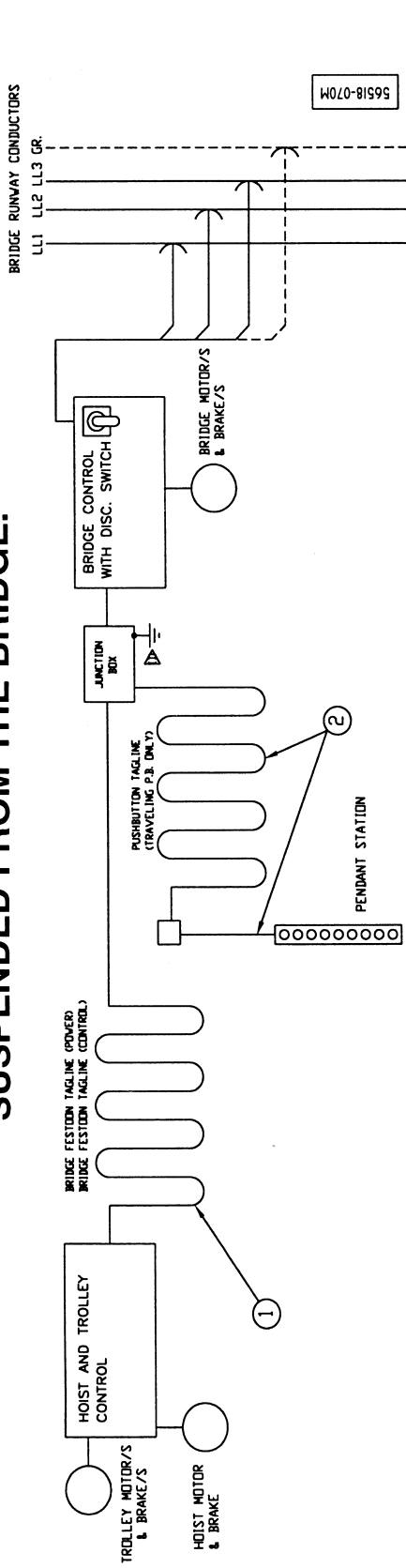

WIRE	DESCRIPTION
10	HOIST UP
11	HOIST DOWN
12	HOIST 2ND SPEED
(13)	HOIST 3RD SPEED
(14)	HOIST 4TH SPEED
(15)	HOIST 5TH SPEED
20	TROLLEY RIGHT
21	TROLLEY LEFT
22	TROLLEY 2ND SPEED
(23)	TROLLEY 3RD SPEED
(24)	TROLLEY 4TH SPEED
(25)	TROLLEY 5TH SPEED
30	BRIDGE FORWARD
31	BRIDGE REVERSE
32	BRIDGE 2ND SPEED
(33)	BRIDGE 3RD SPEED
(34)	BRIDGE 4TH SPEED
(35)	BRIDGE 5TH SPEED
40	MAINLINE ON
41	MAINLINE OFF

WIRE GROUP	SINGLE SPEED BRIDGE WITH:		MULTI-SPEED HOIST	
	SINGLE-SPEED TROLLEY	MULTI-SPEED TROLLEY	SINGLE-SPEED TROLLEY	MULTI-SPEED TROLLEY
1	X1, 10, 11, 20, 21, GR.	X1, GR., 10, 11, 12, (13), (14), (15), 20, 21	X1, GR., 10, 11, 12, (13), (14), (15), 20, 21	X1, GR., 10, 11, 12, (13), (14), (15), 20, 21, (22), (23), (24), (25)
2	L1, L2, L3, GR.	L1, L2, L3, GR.	L1, L2, L3, GR.	L1, L2, L3, GR.
1	X1, GR., 10, 11, 20, 21, 30, 31, 40, 41	X1, GR., 10, 11, 20, 21, 22, (23), (24), (25), 30, 31, 40, 41	X1, GR., 10, 11, 12, (13), (14), (15), 20, 21, 30, 31, 40, 41	X1, GR., 10, 11, 12, (13), (14), (15), 20, 21, (22), (23), (24), (25), 30, 31, 40, 41
2	L1, L2, L3, GR.	L1, L2, L3, GR.	L1, L2, L3, GR.	L1, L2, L3, GR.
1	X1, GR., 10, 11, 20, 21, 30, 31, 32, (33), (34), (35), 40, 41	X1, GR., 10, 11, 20, 21, 22, (23), (24), (25), 30, 31, 32, (33), (34), (35), 40, 41	X1, GR., 10, 11, 12, (13), (14), (15), 20, 21, 30, 31, 32, (33), (34), (35), 40, 41	X1, GR., 10, 11, 12, (13), (14), (15), 20, 21, (22), (23), (24), (25), 30, 31, 32, (33), (34), (35), 40, 41
2	L1, L2, L3, GR.	L1, L2, L3, GR.	L1, L2, L3, GR.	L1, L2, L3, GR.

NOTE:
 BOND ALL GROUNDING CONDUCTORS TO METALLIC JUNCTION BOXES OR CONTROL PANEL GROUNDING TERMINAL.
 CONDUCTOR SIZE MUST BE IN ACCORDANCE WITH SECTION 610 OF ANS/NFPA 70 (NATIONAL ELECTRICAL CODE) OR SECTION 40 OF THE CANADIAN ELECTRICAL CODE.
 REFERENCE CHART LISTED ON THE DRAWING TO IDENTIFY CONDUCTOR NUMBER/FUNCTION.
 WHEN VARIABLE FREQUENCY INVERTER DRIVES ARE USED TO CONTROL ANY MOTION, POWER AND CONTROL CONDUCTORS MUST BE KEPT SEPARATE INSIDE OF CONTROL PANELS AND ROUTED THROUGH SEPARATE CONDUITS ON THE EQUIPMENT.
 "MULTI-SPEED" IN THE CHART MATRIX INCLUDES CONDUCTOR REQUIREMENT INFORMATION FOR TWO-SPEED, TWO-STEP INFINITELY VARIABLE SPEED, THREE-SPEED, THREE-STEP INFINITELY VARIABLE SPEED, FOUR-SPEED AND FIVE-SPEED MOTION CONNECTIONS.
 FOR TWO-SPEED OR TWO-STEP INFINITELY VARIABLE SPEED OPERATION, PROVIDE ALL CONDUCTORS NOT LISTED IN PARENTHESIS IN THE MULTI-SPEED MATRIX BLOCK.
 FOR THREE-SPEED OR THREE-STEP INFINITELY VARIABLE SPEED OPERATION, CONDUCTOR NUMBERS (13)-HOIST, (23)-TROLLEY AND/OR (33)-BRIDGE ARE ADDED TO THE TWO-SPEED CONDUCTORS.
 FOR FOUR-SPEED OPERATION, CONDUCTOR NUMBERS (14)-HOIST, (24)-TROLLEY AND/OR (34)-BRIDGE ARE ADDED TO THE CONDUCTOR REQUIREMENT FOR THREE-SPEED OPERATION.
 FOR FIVE-SPEED OPERATION, CONDUCTOR NUMBERS (15)-HOIST, (25)-TROLLEY AND/OR (35)-BRIDGE ARE ADDED TO THE CONDUCTOR REQUIREMENT FOR FOUR-SPEED OPERATION.
 X1'S FROM ALL CONTROL TRANSFORMERS ARE CONNECTED TOGETHER, UNLESS X2'S ARE GROUNDING.

⚠ DANGER
 DISCONNECT POWER AND LOCKOUT/TAGOUT.
 DISCONNECTING MEANS BEFORE REMOVING COVER OR SERVICING THE EQUIPMENT.
 SERVICE SHOULD BE PERFORMED ONLY BY A QUALIFIED ELECTRICIAN.
 DO NOT OPERATE WITHOUT COVER IN PLACE.

⚠ CAUTION
 WIRING DIAGRAMS SHOWN ARE "TYPICAL" AND MAY NOT INCLUDE ALL DEVICES SUPPLIED WITH A PARTICULAR CONTROL. ALWAYS REFER TO THE WIRING DIAGRAM PROVIDED INSIDE OF THE CONTROL ENCLOSURE COVER OF A SPECIFIC PIECE OF EQUIPMENT, BEFORE PERFORMING ANY SERVICE.

TYPICAL WIRING DIAGRAM

TYPICAL WIRING DIAGRAM SINGLE SPEED BRIDGE WITH ACM

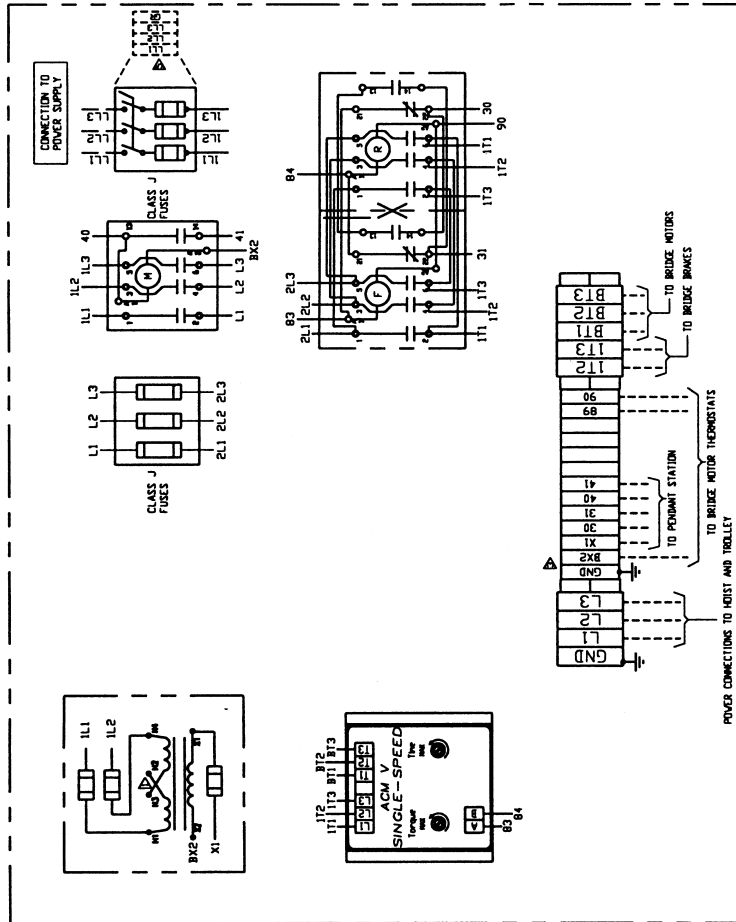

BRIDGE CONTROL PANEL

ACCO STANDARD MOTOR CONNECTIONS	
VOLTAGE	BT1 BT2 BT3 CONNECT TOGETHER
230	11, 17, 12, 18, 13, 19, 14, 15, 16
460	T1, T2, T3 (T4, T5, T6, T7, T8, T9, T10)

SINGLE SPEED MOTOR
 ALL MOTOR THERMOSTATS TO BE WIRED IN SERIES

ACCO STANDARD MOTOR BRAKE CONNECTIONS	
VOLTAGE	BT1 BT2 BT3 CONNECT TOGETHER
230V	112, 113, 114, 115, 116, 117, 118, 119, 120, 121, 122, 123, 124, 125, 126, 127, 128, 129, 130, 131, 132, 133, 134, 135, 136, 137, 138, 139, 140, 141, 142, 143, 144, 145, 146, 147, 148, 149, 150, 151, 152, 153, 154, 155, 156, 157, 158, 159, 160, 161, 162, 163, 164, 165, 166, 167, 168, 169, 170, 171, 172, 173, 174, 175, 176, 177, 178, 179, 180, 181, 182, 183, 184, 185, 186, 187, 188, 189, 190, 191, 192, 193, 194, 195, 196, 197, 198, 199, 200
460V	T1, T2, T3 (T4, T5, T6, T7, T8, T9, T10)

230V AND 460V MOTORS AND BRACKES MUST BE WIREWOUND AND NOT RE-CONNECTABLE

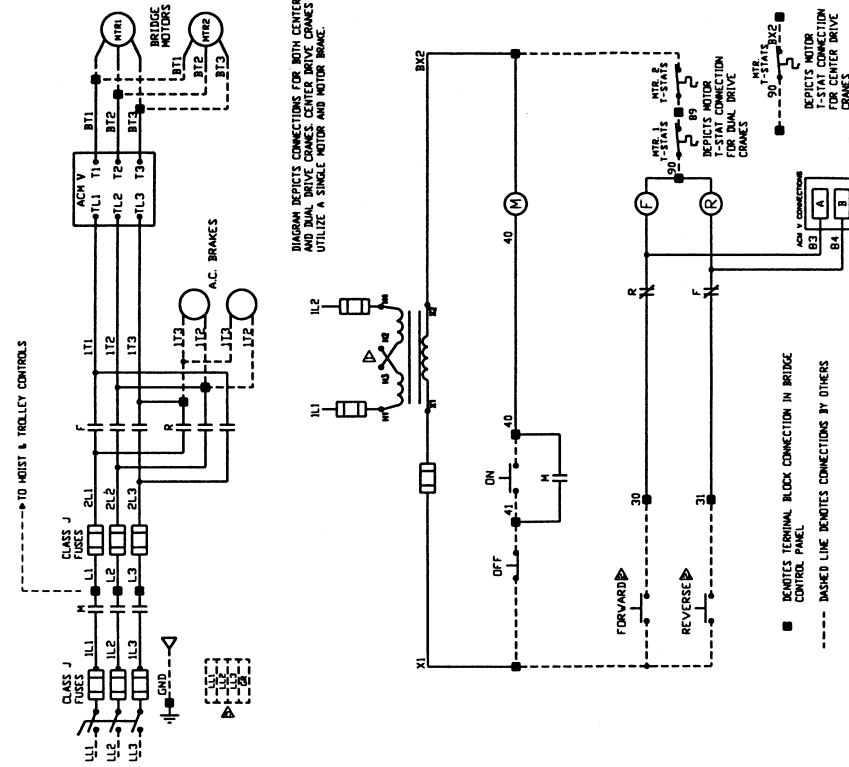

⚠ DANGER
DISCONNECT POWER AND LOCKOUT/TAGOUT. DISCONNECTING MEANS BEFORE REMOVING COVER OR SERVICING THIS EQUIPMENT. SERVICE SHOULD BE PERFORMED ONLY BY A QUALIFIED ELECTRICIAN.
DO NOT OPERATE WITHOUT COVER IN PLACE.

▲ POWER CONNECTION TERMINALS ARE SUPPLIED ON CONTROL PANELS ORDERED WITHOUT INTEGRAL FUSED DISCONNECT SWITCH.
 ▲ BRIDGE CONNECTION DETAIL SHOWN DEPICTS ACCO STANDARD MOTOR BRAKE.
 ▲ ON MODELS PROVIDED WITH A NON-STANDARD MOTOR BRAKE, CONSULT WIRING DETAIL INSIDE MOTOR BRIDGE COVER FOR CONNECTION INFORMATION.
 ▲ TO GROUND TRANSFORMER X2, CONNECT A JUMPER WIRE FROM CONTROL CIRCUIT GROUND TERMINAL TO TERMINAL X2. SIZE AND COLOR OF JUMPER MUST COMPLY WITH CURRENT NEC AND CCC REQUIREMENTS. WHEN GROUNDING X2, X1'S FROM MULTIPLE TRANSFORMERS MUST NOT BE CONNECTED IN COMMON.
 ▲ SUBSTITUTE RIGHT-LEFT, NORTH-SOUTH, EAST-WEST WHEN APPLICABLE.
 ▲ MULTIPLE VOLTAGE COMPONENTS MUST BE CONNECTED AS PER NAMEPLATE DATA, TO SWITCH SUPPLY VOLTAGE.

8058-001H

TYPICAL WIRING DIAGRAM

TYPICAL WIRING DIAGRAM TWO SPEED BRIDGE WITH ACM

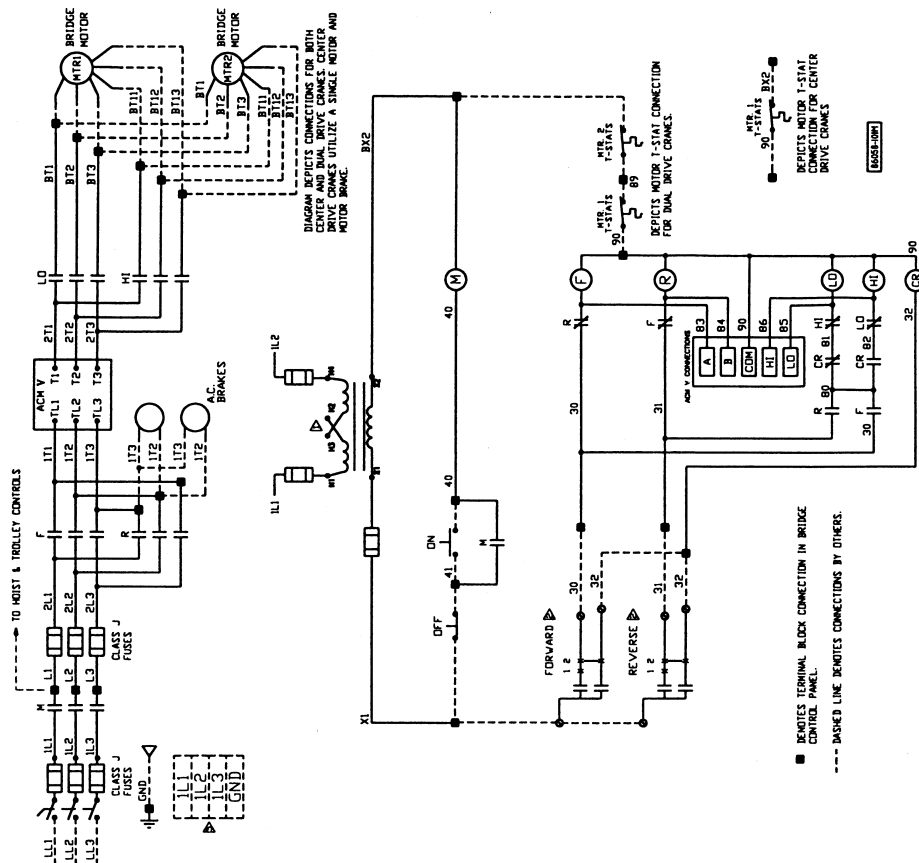

⚡ DANGER

DISCONNECT POWER AND LOCKOUT/TAGOUT. DISCONNECT AND LOCKOUT/TAGOUT COVER OR SERVICING THIS EQUIPMENT.

SERVICE SHOULD BE PERFORMED ONLY BY A QUALIFIED ELECTRICIAN.

DO NOT OPERATE WITHOUT COVER IN PLACE.

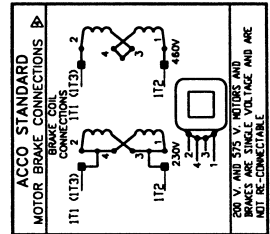
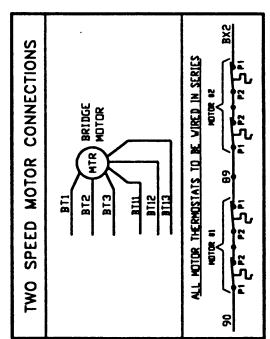
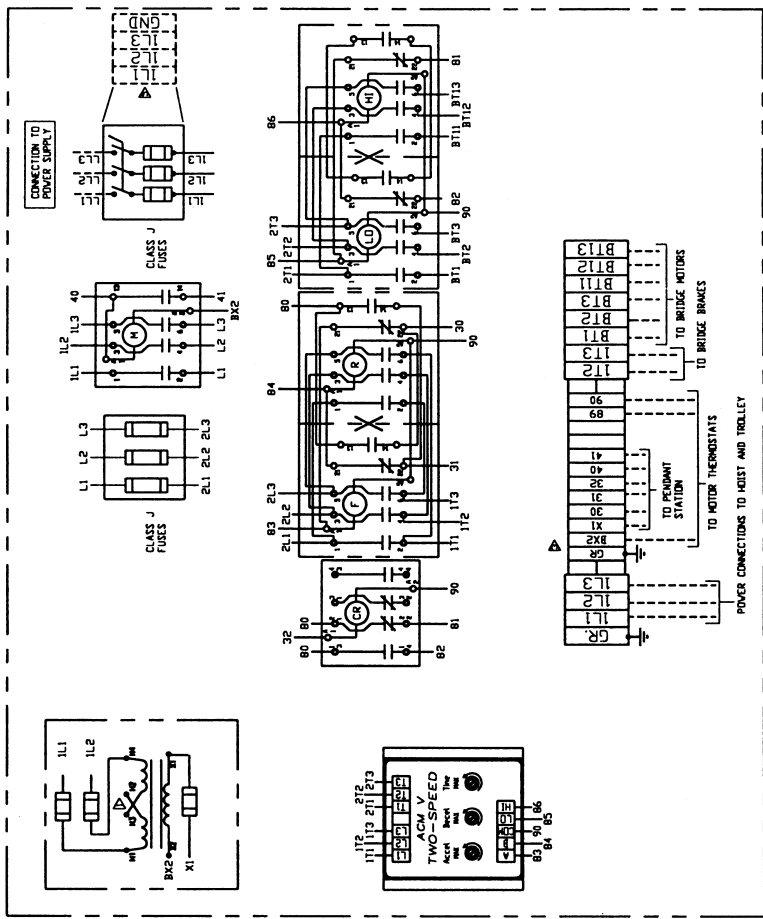

- NOTES:
- ▷ POWER CONNECTION TERMINALS ARE SUPPLIED ON CONTROL PANELS ORDERED WITHOUT INTEGRAL FUSED DISCONNECT SWITCH.
 - ▷ BRIDGE CONNECTION DETAIL SHOWN REPRESENTS ACCO STANDARD MOTOR BRAKE ON MODELS PROVIDED WITH A NON-STANDARD MOTOR BRAKE. CONSULT WIRING DETAIL INSIDE MOTOR BRAKE COVER FOR CONNECTION INFORMATION.
 - ▷ TO GROUND, TRANSFORMER Y2 CONNECT A JUMPER FROM THE CONTROL CIRCUIT GROUND TERMINAL TO TERMINAL 32. SIZE AND COLOR OF JUMPER WIRE MUST COMPLY WITH CURRENT NEC AND DEC REQUIREMENTS. WHEN GROUNDING RE'S, XIS FROM MULTIPLE TRANSFORMERS MUST NOT BE CONNECTED IN COMMON.
 - ▷ SUBSTITUTE RIGHT-LEFT, NORTH-SOUTH, EAST-WEST WHEN APPLICABLE.
 - ▷ MULTIPLE VOLTAGE COMPONENTS MUST BE CONNECTED AS PER NAMEPLATE DATA, TO MATCH SUPPLY VOLTAGE.

TYPICAL WIRING DIAGRAM

TYPICAL WIRING DIAGRAM INVERTER CONTROLLED BRIDGE

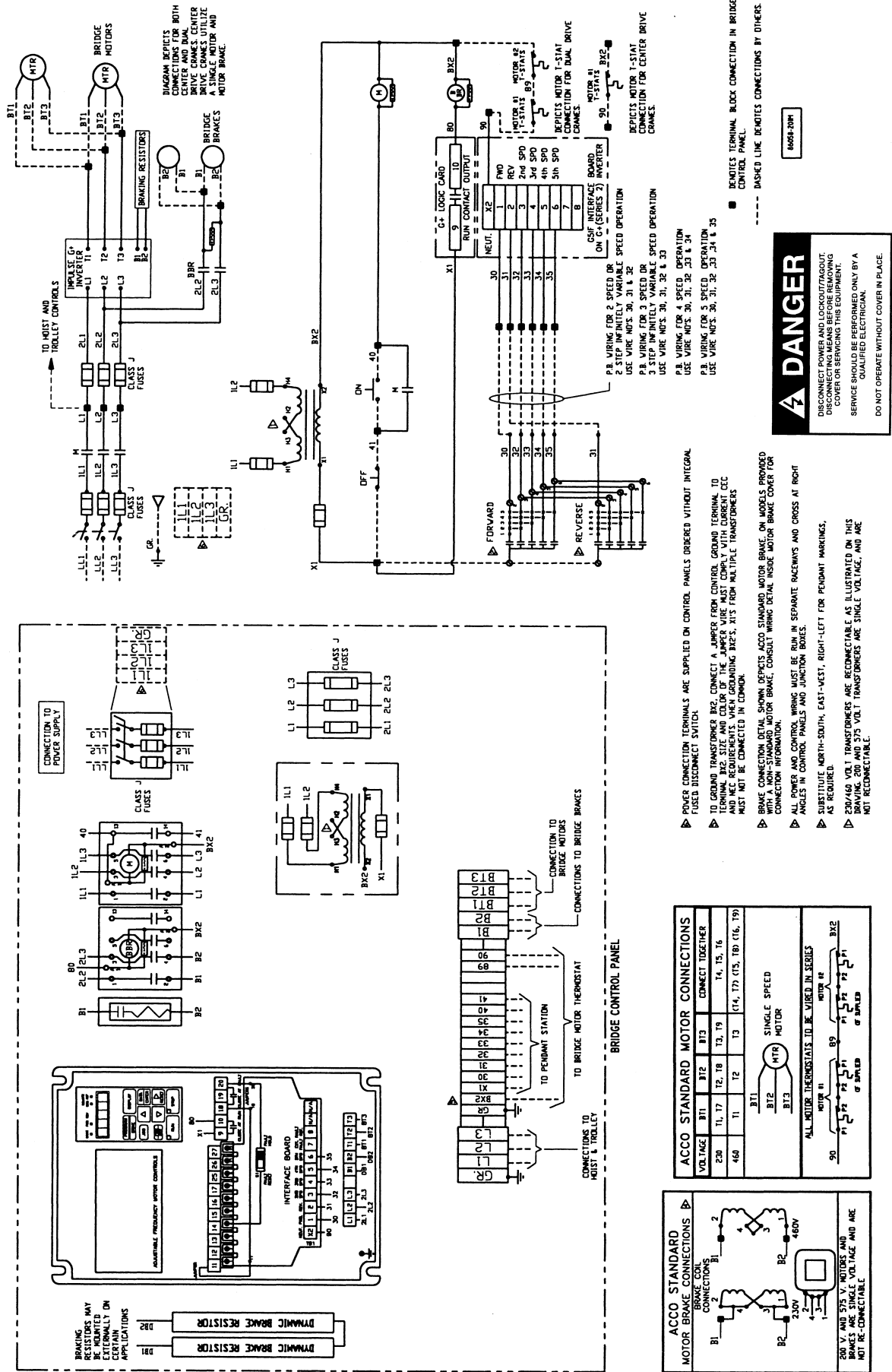

**THIS PAGE INTENTIONALLY
LEFT BLANK**

PARTS LIST – CRANE DRIVE MOTOR BRAKE

CRANE DRIVE MOTOR BRAKE ASSEMBLY

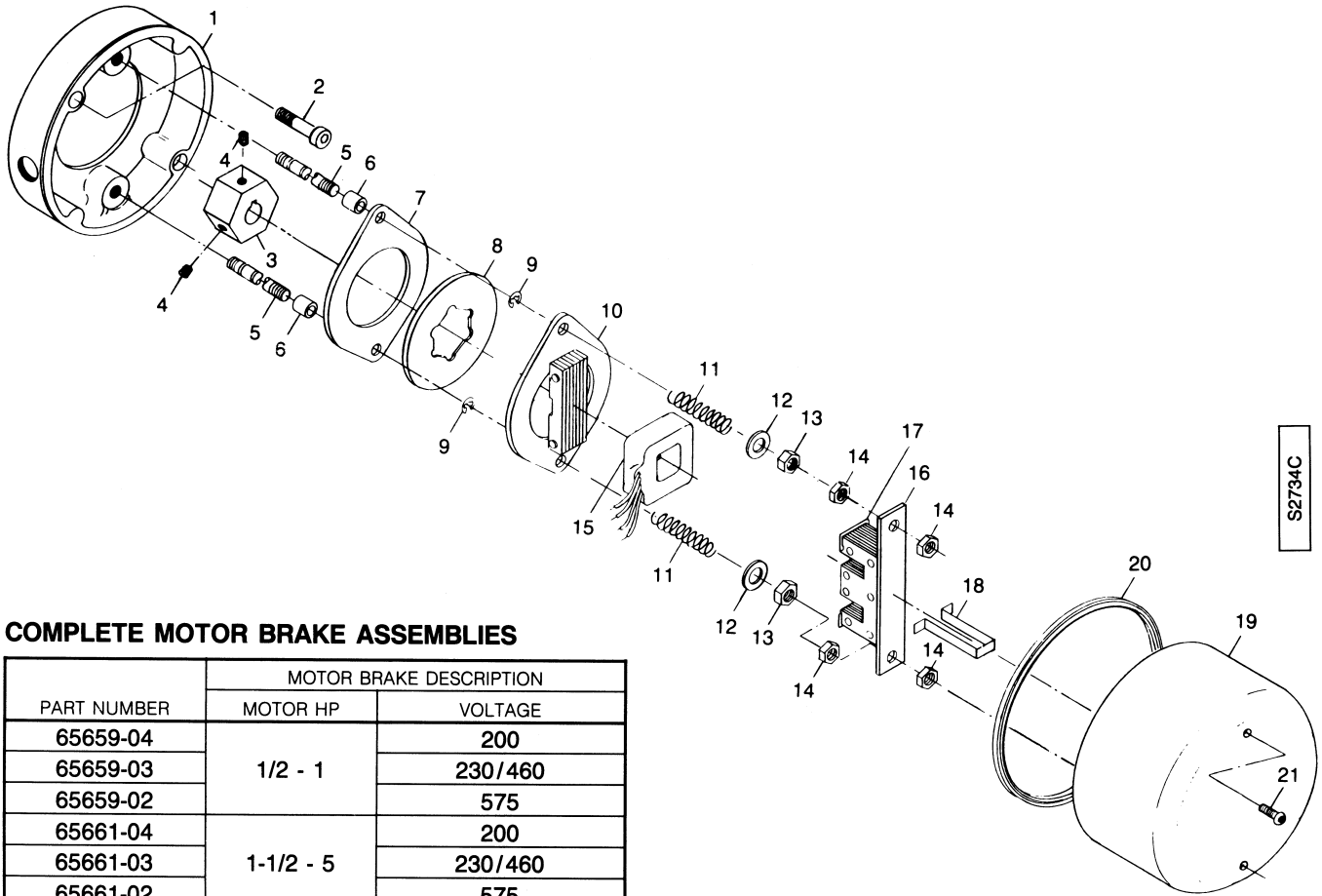

S2784C

COMPLETE MOTOR BRAKE ASSEMBLIES

PART NUMBER	MOTOR BRAKE DESCRIPTION	
	MOTOR HP	VOLTAGE
65659-04	1/2 - 1	200
65659-03		230/460
65659-02		575
65661-04	1-1/2 - 5	200
65661-03		230/460
65661-02		575

CRANE DRIVE MOTOR BRAKE PARTS

ITEM NO.	PART NUMBER	DESCRIPTION	QTY/ ASSY
1	65653	Adapter	1
2	1-6-24	Bolt, 3/8-16 x 1-1/2 lg	2
3	65654	Hub	1
4	12-4-6	Set Screw	2
5	65655	Stud	2

ITEM NO.	PART NUMBER	MOTOR HP	DESCRIPTION	QTY/ ASSY
6	61459	1/2 - 1	Spacer	2
		1-1/2 - 5		0
7	39794	1/2 - 1	Brake Plate	1
		1-1/2 - 5		2
8▲	39649	1/2 - 1	Brake Lining	1
		1-1/2 - 5		2
9	PA5623	Retaining Ring	2	

ITEM NO.	PART NUMBER	DESCRIPTION	QTY/ ASSY
10	39781	Pressure Unit	1
11	PA5823	Spring	2
12	15-6-1	Flat Washer	2
13	PA2377	Locknut, 3/8	2
14	24-6	Jam Nut, 3/8	4
15▲	39783-6	Coil, 200 Volts	1
	39783-3	Coil, 230/460 Volts	
	39783-2	Coil, 575 Volts	
16	39780	Magnet Unit	1
17	39784	Shading Coil (a)	2
18	39877	Coil Strap	1
19	69161	Brake Cover	1
20	PA7110	Gasket	1.77 ft
21▲	PA7323	Screw, LOC-WEL, #10-24 (b)	2

▲ Recommended Spare Parts

- (a) Shading Coil is furnished with Magnet Unit, but also available as a spare.
- (b) Screw with self-locking feature must be utilized. Substitutes are not permissible.

PARTS LIST – CRANE DRIVE MOTOR

CRANE DRIVE MOTOR

Crane drive motors for steel-wheel drive units and 2 horsepower maximum 3A107 drive units have two shaft extensions, and the crane drive motor brake mounts on one end of the motor. Crane drive motors for 3 to 5 horsepower 3A107 drive units have one shaft extension, and the crane drive motor brake mounts on the opposite side of the drive. Select motor as specified from the following:

PART NO. MOTOR WITH ONE SHAFT EXT.	PART NO. MOTOR WITH TWO SHAFT EXT.	VOLTAGE	HP	RPM	SPEED	FRAME		
61010-34 61010-35 61010-36	65818-19 65818-20 65818-21	200 208/230/460 575	1/2	1200	SINGLE	56C		
61010-37 61010-38 61010-39	65818-22 65818-23 65818-24	200 208/230/460 575	3/4					
61010-31 61010-32 61010-33	65818-25 65818-26 65818-27	200 208/230/460 575	1					
61010-01 61010-02 61010-03	65818-04 65818-05 65818-06	200 208/230/460 575	1/2	1800			SINGLE	56C
61010-25 61010-26 61010-27	65818-07 65818-08 65818-09	200 208/230/460 575	3/4					
61010-04 61010-05 61010-06	65818-10 65818-11 65818-12	200 208/230/460 575	1					
61010-07 61010-08 61010-09	65818-13 65818-14 65818-15	200 208/230/460 575	1 1/2					
61010-10 61010-11 61010-12	65818-16 65818-17 65818-18	200 208/230/460 575	2					
69180-01 69180-02 69180-03	N/A N/A N/A	200 208/230/460 575	3					
69180-04 69180-05 69180-06	N/A N/A N/A	200 208/230/460 575	5	184TC				
N/A N/A N/A N/A	65819-21 65819-22 65819-23 65819-24	200 230 460 575	1/2 / 1/4	1200/600	TWO	56C		
N/A N/A N/A N/A	65819-25 65819-26 65819-27 65819-28	200 230 460 575	3/4 / 3/8					
N/A N/A N/A N/A	65819-29 65819-30 65819-31 65819-32	200 230 460 575	1 / 1/2					
61012-01 61012-02 61012-03 61012-04	65819-01 65819-02 65819-03 65819-04	200 230 460 575	1/2 / 1/6	1800/600			TWO	56C
61012-13 61012-14 61012-15 61012-16	65819-05 65819-06 65819-07 65819-08	200 230 460 575	3/4 / 1/4					
61012-05 61012-06 61012-07 61012-08	65819-09 65819-10 65819-11 65819-12	200 230 460 575	1 / 1/3					
61012-17 61012-18 61012-19 61012-20	65819-33 65819-34 65819-35 65819-36	200 230 460 575	1 1/2 / 1/2					
61012-21 61012-22 61012-23 61012-24	65819-17 65819-18 65819-19 65819-20	200 230 460 575	2 / 2/3					
69181-01 69181-02 69181-03 69181-04	N/A N/A N/A N/A	200 230 460 575	3 / 1					
69181-05 69181-06 69181-07 69181-08	N/A N/A N/A N/A	200 230 460 575	5 / 1 2/3	213TC				

For other specified special motors, refer to additional information pages supplied with manual.

PARTS LIST - STEEL WHEEL DRIVE ASSEMBLY

STEEL WHEEL DRIVE ASSEMBLY

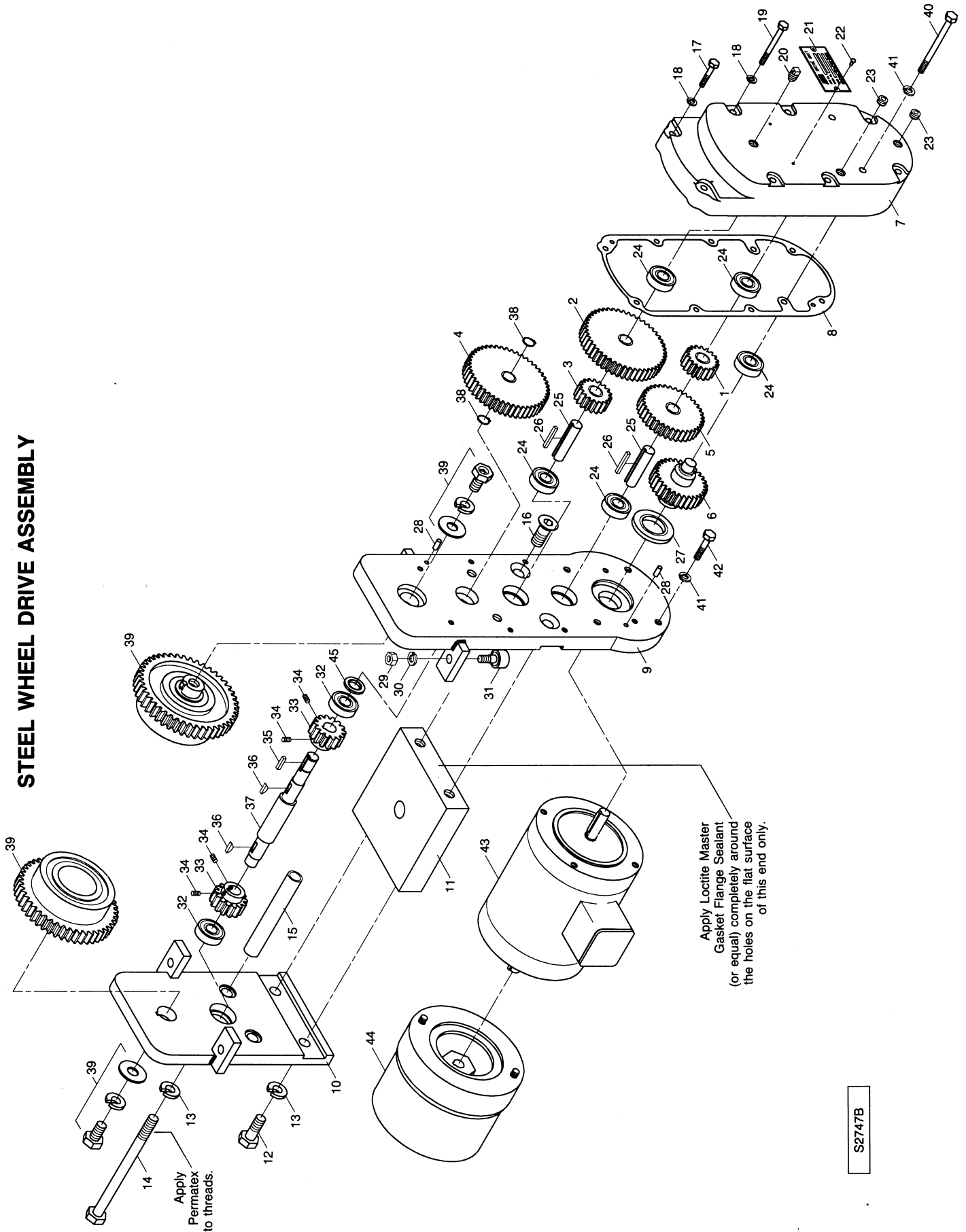

S2747B

PARTS LIST – STEEL WHEEL DRIVE ASSEMBLY

STEEL WHEEL DRIVE ASSEMBLIES

NOMINAL SPEED	ASSEMBLY PART NUMBER	MOTOR (RPM)
50 FPM	69500-01	1200
75 FPM	69500-01	1800
100 FPM	69500-02	1800
125 FPM	69500-03	1800
150 FPM	69500-04	1800

NOMINAL SPEED	ASSEMBLY PART NUMBER	MOTOR (RPM)
50/25 FPM	69500-01	1200/600
75/25 FPM	69500-01	1800/600
100/33 FPM	69500-02	1800/600
125/42 FPM	69500-03	1800/600
150/50 FPM	69500-04	1800/600

STEEL WHEEL DRIVE PARTS

ITEM NO.	DESCRIPTION	ASSEMBLY NO. 69500-01	ASSEMBLY NO. 69500-02	ASSEMBLY NO. 69500-03	ASSEMBLY NO. 69500-04
1	Reduction Gear	67378 (18 teeth)	67378 (18 teeth)	67379 (22 teeth)	69514 (30 teeth)
2	Reduction Gear	67388 (48 teeth)	67388 (48 teeth)	67387 (44 teeth)	67384 (36 teeth)
3	Reduction Gear	67378 (18 teeth)	67379 (22 teeth)	67379 (22 teeth)	67378 (18 teeth)
4	Reduction Gear	67388 (48 teeth)	67387 (44 teeth)	67387 (44 teeth)	67388 (48 teeth)

ITEM NO.	PART NUMBER	DESCRIPTION	QTY/ ASSY
5	67384	Reduction Gear (36 teeth)	1
6	69513	Input Gear (30 teeth)	1
7	69509	Gear Cover	1
8▲	69515	Gasket	1
9	69516	Geared Sideplate	1
10	69093	Plain Sideplate	1
11	69133	Crosshead	1
12	35-10-24	Bolt, 5/8-11 x 1-1/2"	2
13	17-10	Lockwasher, 5/8"	4
14	PA7184	Bolt, 5/8-11 x 7-1/2"	2
15	67394	Yoke Spacer	2
16	PA5465	Flat Head Hex Socket Screw	2
17	35-5-24	Bolt, 5/16-18 x 1-1/2"	2
18	17-5C	Lockwasher, 5/16"	8
19	35-5-44	Bolt, 5/16-18 x 2-3/4"	6
20	PA7350	Breather Plug	1
21	69106	Nameplate	1
22	PA897	Drive Screw	2
23	PA786	Pipe Plug	2
24	PA2464	Bearing	5

ITEM NO.	PART NUMBER	DESCRIPTION	QTY/ ASSY
25	67376	Intermediate Shaft	2
26	67414	Key	1
27▲	PA6622	Oil Seal	1
28	PA5439	Dowel Pin	2
29	23-7	Nut, 7/16-20	4
30	17-7C	Lockwasher, 7/16"	4
31	PA7317	Cam Follower	4
32	PA1796	Bearing	2
33	62214	Spur Pinion	2
34	12-4-4C	Set Screw, 1/4 x 1/4"	4
35	67413	Key	1
36	PA1357	Woodruff Key	2
37	69134	Pinion Shaft	1
38	PA2470	Retaining Ring	2
39	280594	Geared Wheel Assembly	2
40	35-6-64	Bolt, 3/8-16 x 4"	2
41	17-6C	Lockwasher, 3/8"	4
42	35-6-24	Bolt, 3/8-16 x 1-1/2"	2
43▲	(a)	Motor	1
44	(b)	Motor Brake	1
45▲	PA7395	Oil Seal	1
46▲	(c)	Grease (Not Shown)	

▲ Recommended Spare Parts

NOTES:

- (a) For part numbers of motors, refer to page 59.
- (b) For part numbers of motor brake assemblies and motor brake parts, refer to page 58.
- (c) Exposed gears and pinions on steel-wheel drive unit are shipped from the factory without lubricant. Lyondell® EP Moly D Grease, packaged in a 4-ounce squeeze bottle container, is furnished with all steel-wheel drive units. Refer to the LUBRICATION section of this manual. Additional containers of Lyondell® EP Moly D Grease, packaged in a 4-ounce squeeze bottle, can be obtained by ordering ACCO® part no. 69807.

PARTS LIST – 3A107 DRIVE ASSEMBLY

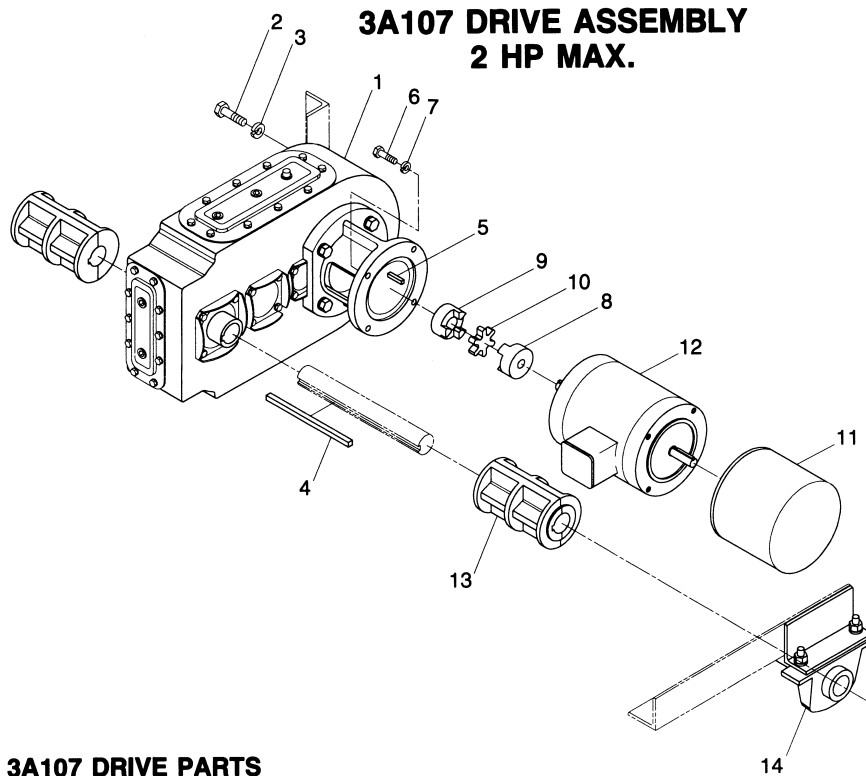

3A107 DRIVE PARTS

ITEM NO.	PART NUMBER	DESCRIPTION	QTY
1	222743 222744 222745 222746	Gear Reducer 50 & 75 FPM 110 FPM 135 FPM 165 FPM	1
2	210925	Bolt	2
3	210409	Lockwasher	2
4	540292	Key	1
5	540288	Key	1
6	210865	Bolt	4
7	210407	Lockwasher	4
8	222601	Coupling Half - Motor Side	1
9	222602	Coupling Half - Reducer Side	1
10▲	222606	Coupling Spider	1
11	(a)	Motor Brake	1
12▲	(b)	Motor	1
13	260186 260361 260411	Compression Coupling 1-7/16 dia. 2-3/16 dia. 1-7/16 x 2-3/16 dia.	(c)
14	301500 301502	Pillow Block Assembly 1-7/16 dia. 2-3/16 dia.	(c)

▲ Recommended Spare Parts

NOTES:

(a) For part numbers of motor brake assemblies and motor brake parts, refer to page 58.

(b) For part numbers of motors, refer to page 59.

(c) As required.

PARTS LIST – 3A107 DRIVE ASSEMBLY

3A107 DRIVE ASSEMBLY 3 AND 5 HP

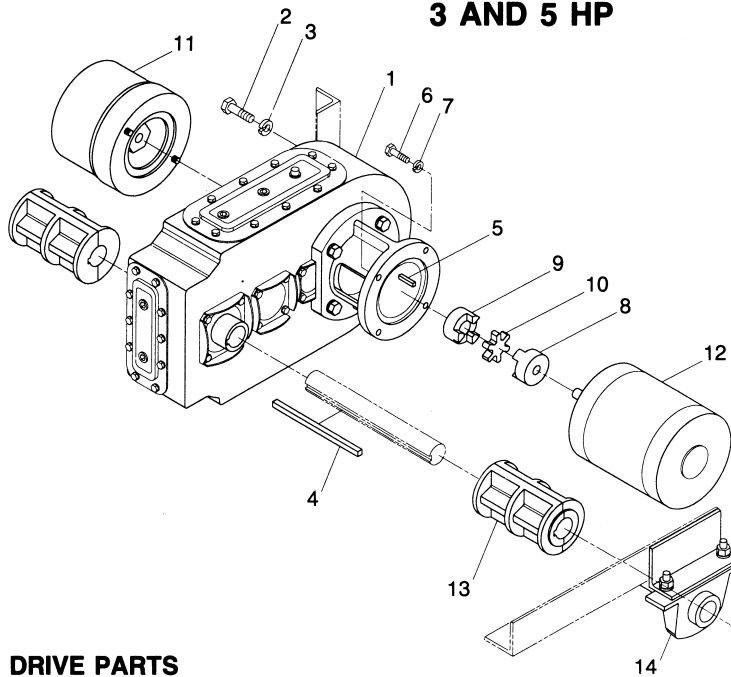

3A107 DRIVE PARTS

ITEM NO.	PART NUMBER	DESCRIPTION	QTY
1	222756 222757 222758	Gear Reducer 110 FPM 135 FPM 165 FPM	1
2	210925	Bolt 4	2
3	210409	Lockwasher	2
4	540292	Key	1
5	540288	Key	1
6	210926	Bolt	4
7	210409	Lockwasher	4
8	222604 222604 222605	Coupling Half - Motor Side 3 HP 5 HP Single Speed 5 HP Two Speed	1
9	222603	Coupling Half - Reducer Side	1
10▲	222607	Coupling Spider	1
11	(a)	Motor Brake	1
12▲	(b)	Motor	1
13	260186 260361 260411	Compression Coupling 1-7/16 dia. 2-3/16 dia. 1-7/16 x 2-3/16 dia.	(c)
14	301500 301502	Pillow Block Assembly 1-7/16 dia. 2-3/16 dia.	(c)

▲ Recommended Spare Parts

NOTES:

- (a) For part numbers of motor brake assemblies and motor brake parts, refer to page 58.
- (b) For part numbers of motors, refer to page 59.
- (c) As required.

PARTS LIST – 9 INCH DRIVE TIRE ASSEMBLY

9 INCH DRIVE TIRE ASSEMBLY

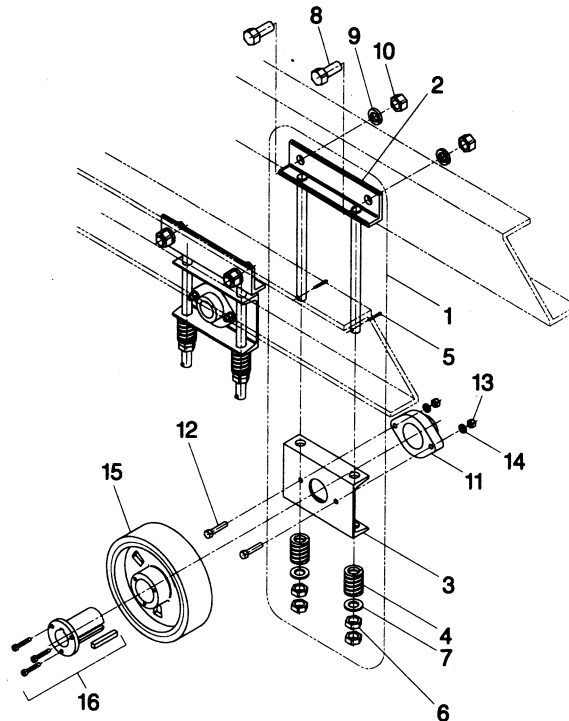

COMPLETE DRIVE TIRE ASSEMBLY

Part No. 410504: 7 inch back-to-back channel, single take-up.

Part No. 410505: 10 inch and 12 inch back-to-back channel, double take-up.

DRIVE TIRE ASSEMBLY PARTS

ITEM NO.	PART NUMBER	DESCRIPTION	QTY ASSEMBLY 410504	QTY ASSEMBLY 410505
1	260672	Take-up Frame Assm.	1	2
2	260671	Bracket (a)	1	2
3	260670	Bearing Mount (a)	1	2
4	214287	Compression Spring (a)	2	4
5	210469	Cotter Pin (a)	2	4
6	211715	Hex Jam Nut (a)	4	8
7	210223	Washer (a)	2	4
8	211072	Bolt	2	4
9	210411	Lockwasher	2	4
10	211720	Hex Nut	2	4
11	213670	Flange Bearing	1	2
12	210867	Bolt	2	4
13	211547	Hex Nut	2	4
14	210407	Lockwasher	2	4
15▲	260536	9 Inch Drive Tire	1	1
16	213534	Split Taper Bushing Kit	1	1

▲Recommended Spare Parts

NOTES:

(a) Included with item no.1, but also available as a spare.

If crane is furnished with a drive tire other than 9 inch diameter, refer to additional information pages supplied with manual.

PARTS LIST – END TRUCK ASSEMBLY

4-WHEEL SUPERTRACK™ END TRUCK ASSEMBLY FOR MODEL 551 CRANE 3000# TRUCK CAPACITY 1'-9" WHEEL BASE 2.0" AND 3.33" OPERATING FLANGE

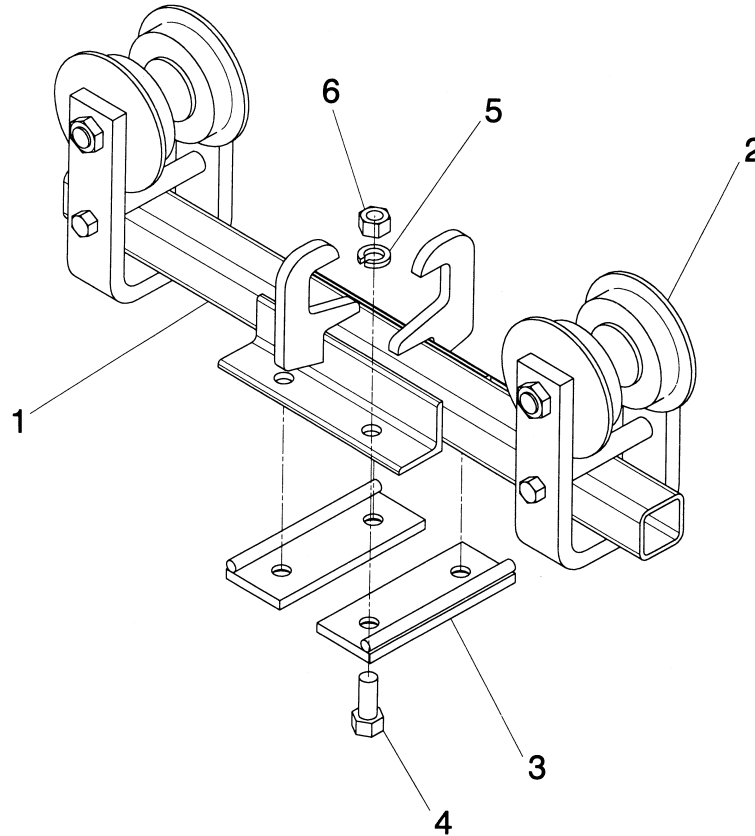

END TRUCK ASSEMBLY PARTS

ITEM NO.	PART NUMBER	DESCRIPTION	QTY
1	260459	Frame	1
2	280027 280474 280056 280480	2-Wheel Trolley Flanged Wheels, 2.0" Operating Flange Flangeless Wheels, 2.0" Operating Flange Flanged Wheels, 3.33" Operating Flange Flangeless Wheels, 3.33" Operating Flange	2
3	260464 260263 N/A	Clamp 602.6 Non-Electrified 603.6 Non-Electrified 602.6, 603.6, and 604.9 Electrified	2
4	213287 210996	Bolt 602.6 and 603.6 Non-Electrified 602.6, 603.6, and 604.9 Electrified	4
5	210410	Lockwasher	4
6	211661	Hex Bolt	4

No Recommended Spare Parts

PARTS LIST – END TRUCK ASSEMBLY

4-WHEEL SUPERTRACK™ END TRUCK ASSEMBLY FOR MODEL 552 CRANE 3000# AND 5000# TRUCK CAPACITY 3'-6" AND 6'-0" WHEEL BASE 2.0" AND 3.33" OPERATING FLANGE

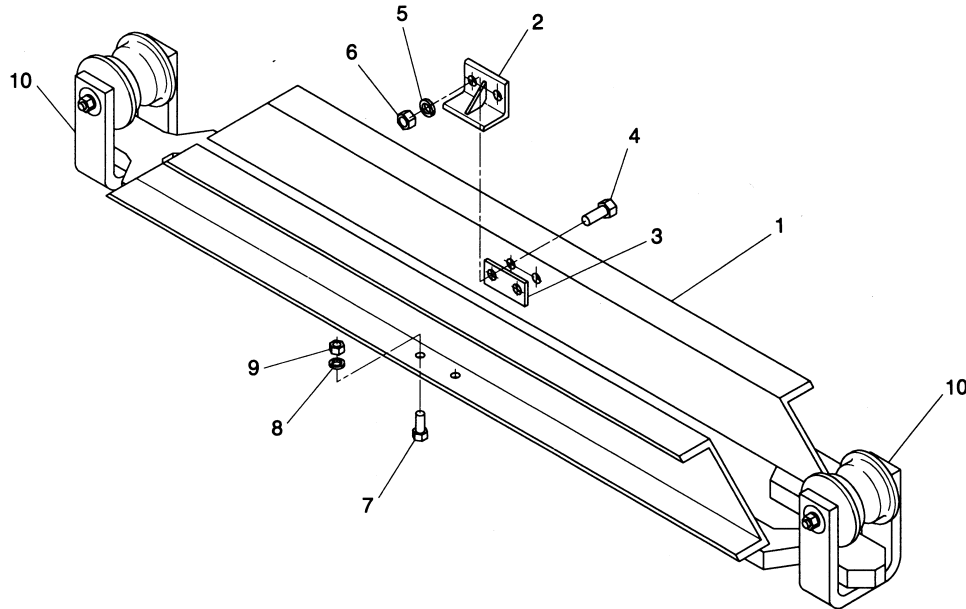

END TRUCK ASSEMBLY PARTS

ITEM NO.	PART NUMBER	DESCRIPTION	QTY
1	265148	Frame	1
	265149	3'-6" Wheelbase 6'-0" Wheelbase	
2	265152	Restraining Lug	2
3	265154	Spacer	2
4	211074	Bolt	4
5	210411	Lockwasher	4
6	211720	Hex Nut	4
7	210999	Bolt	4
8	210410	Lockwasher	4
9	211661	Hex Nut	4
10	280027	2-Wheel Trolley Flanged Wheels, 2.0" Operating Flange, 3000# Capacity	
	280474	Flangeless Wheels, 2.0" Operating Flange, 3000# Capacity	
	280056	Flanged Wheels, 3.33" Operating Flange, 3000# Capacity	
	280480	Flangeless Wheels, 3.33" Operating Flange, 3000# Capacity	
	280059	Flanged Wheels, 3.33" Operating Flange, 5000# Capacity	
	280481	Flangeless Wheels, 3.33" Operating Flange, 5000# Capacity	

No Recommended Spare Parts

PARTS LIST – END TRUCK ASSEMBLY

8-WHEEL SUPERTRACK™ END TRUCK ASSEMBLY FOR MODEL 552 CRANE 6000# AND 10000# TRUCK CAPACITY 2.0" AND 3.33" OPERATING FLANGE

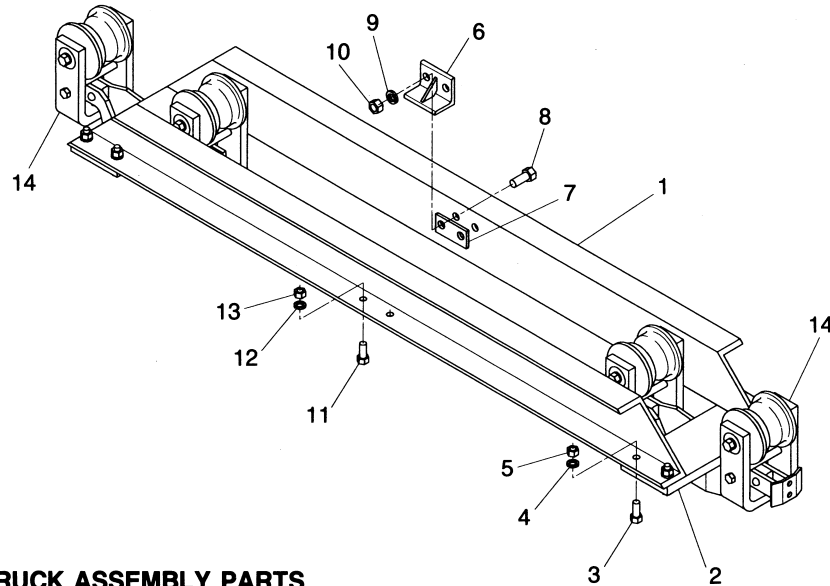

END TRUCK ASSEMBLY PARTS

ITEM NO.	PART NUMBER	DESCRIPTION	QTY
1	265150 265151	Frame 3" - 6" Wheelbase 6" - 0" Wheelbase	1
2	265130	Trolley Adapter (a)	2
3	211000	Bolt (a)	8
4	210410	Lockwasher (a)	8
5	211661	Hex Nut (a)	8
6	265153	Restraining Lug	2
7	265154	Restraining Lug Spacer	2
8	211074	Bolt	4
9	210411	Lockwasher	4
10	211720	Hex Nut	4
11	210999	Bolt	4
12	210410	Lockwasher	4
13	211661	Hex Nut	4
14	301226 301654 280663 301655	4-Wheel Trolley Flanged Wheels, 2.0" Operating Flange, 3000# Capacity Flangeless Wheels, 2.0" Operating Flange, 3000# Capacity Flanged Wheels, 3.33" Operating Flange, 5000# Capacity Flangeless Wheels, 3.33" Operating Flange, 5000# Capacity	2

No Recommended Spare Parts

NOTE:

(a) Included with item no. 1, but also available as a spare.

PARTS LIST – END TRUCK ASSEMBLY

4-WHEEL SUPERTRACK™ END TRUCK ASSEMBLY FOR STEEL WHEEL DRIVE 5000# AND 10000# TRUCK CAPACITY 6'- 0" WHEEL BASE 3.33" OPERATING FLANGE

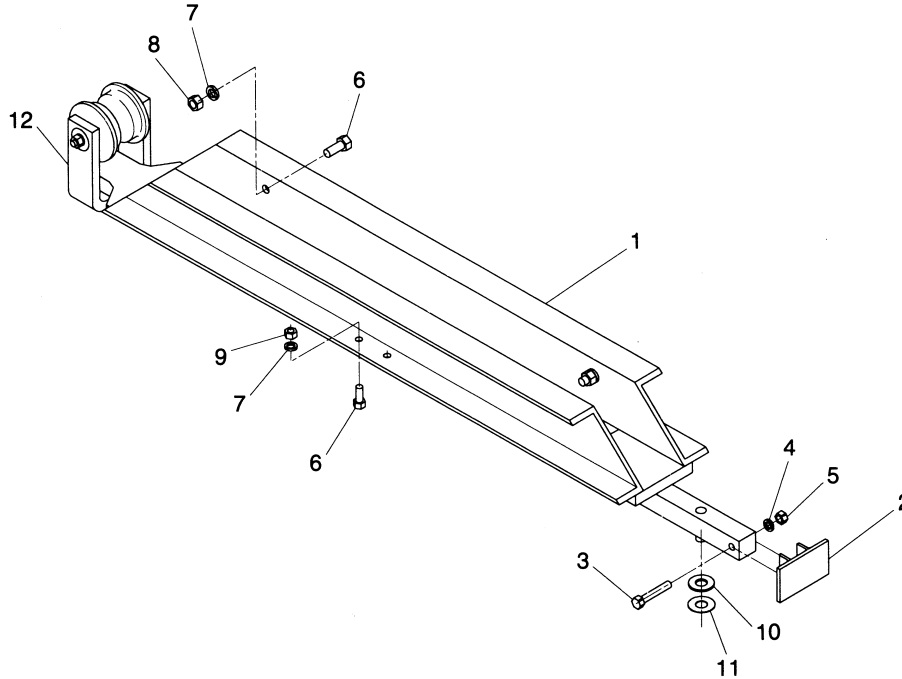

END TRUCK ASSEMBLY PARTS

ITEM NO.	PART NUMBER	DESCRIPTION	QTY
1	265167	Frame	1
2	260119	Bumper (a)	1
3	211005	Bolt (a)	1
4	210410	Lockwasher (a)	1
5	211661	Hex Nut (a)	1
6	210999	Bolt	8
7	210410	Lockwasher	8
8	211664	Hex Jam Nut	4
9	211661	Hex Nut	4
10▲	260194	Steel Bearing Washer	1
11▲	213612	T-2301-4 Thrust Bearing	1
12	280059	2-Wheel Trolley Flanged Wheels, 3.33" Operating Flange, 5000# Truck Capacity	1
	280481	Flangeless Wheels, 3.33" Operating Flange, 5000# Truck Capacity	
	280067	Flanged Wheels, 3.33" Operating Flange, 10000# Truck Capacity	
	280491	Flangeless Wheels, 3.33" Operating Flange, 10000# Truck Capacity	

▲ Recommended Spare Parts

NOTE:

(a) Included with item no. 1, but also available as a spare.

PARTS LIST – END TRUCK ASSEMBLY

8-WHEEL SUPERTRACK™ END TRUCK ASSEMBLY FOR STEEL WHEEL DRIVE 20000# TRUCK CAPACITY 6'-0" WHEEL BASE 3.33" OPERATING FLANGE

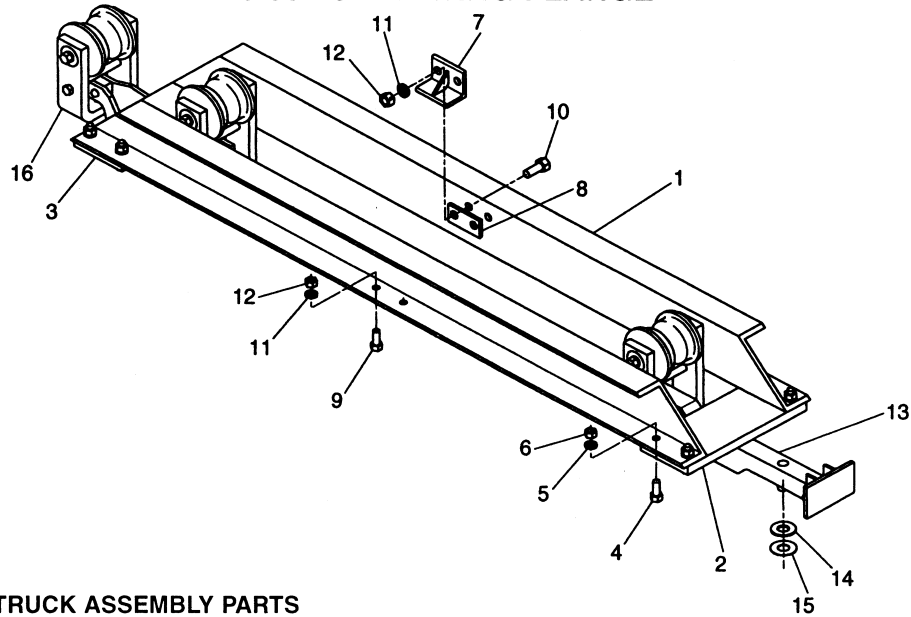

END TRUCK ASSEMBLY PARTS

ITEM NO.	PART NUMBER	DESCRIPTION	QTY
1	265172	Frame	1
2	265128	Steel Wheel Drive End Trolley Adapter (a)	1
3	260303	Idler End Trolley Adapter (a)	1
4	211000	Bolt (a)	8
5	210410	Lockwasher (a)	8
6	211661	Hex Nut (a)	8
7	265153	Restraining Lug	2
8	265154	Restraining Lug Spacer	2
9	211073	Bolt	4
10	211074	Bolt	4
11	210411	Lockwasher	8
12	211720	Hex Nut	8
13	280667	4-Wheel Steel Wheel Drive Trolley Flanged Wheels, 3.33" Operating Flange	1
	301651	Flangeless Wheels, 3.33" Operating Flange	
14 ▲	260194	Steel Bearing Washer (b)	1
15 ▲	213612	T-2301-4 Thrust Bearing (b)	1
16	280664	4-Wheel Idler Trolley Flanged Wheels, 3.33" Operating Flange	1
	301650	Flangeless Wheels, 3.33" Operating Flange	

▲ Recommended Spare Parts

NOTE:

(a) Included with item no. 1, but also available as a spare.

(b) Included with item no. 13, but also available as a spare.

PARTS LIST - END TRUCK ASSEMBLY

4-WHEEL SUPERTRACK™ END TRUCK ASSEMBLY FOR RUBBER TIRE DRIVE 5000# AND 10000# TRUCK CAPACITY 6'- 0" WHEEL BASE 3.33" OPERATING FLANGE

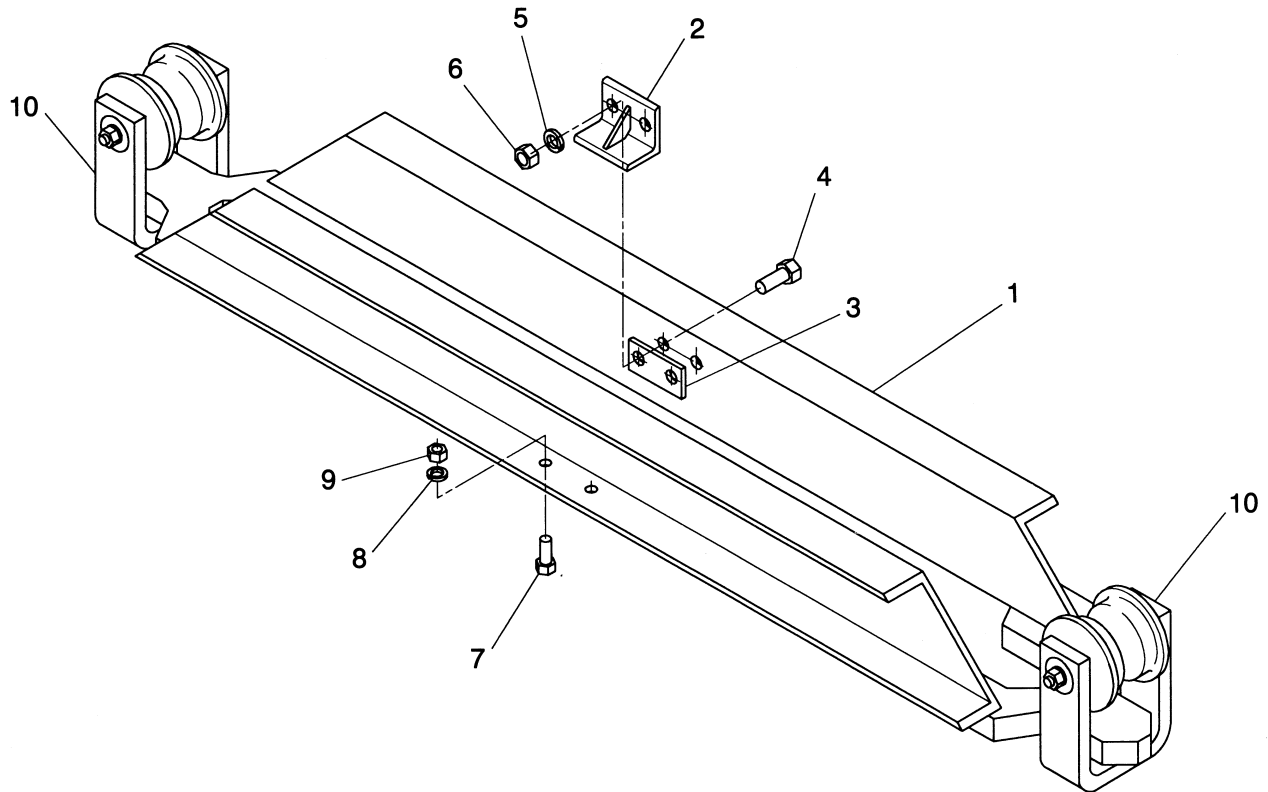

END TRUCK ASSEMBLY PARTS

ITEM NO.	PART NUMBER	DESCRIPTION	QTY
1	265149	Frame	1
2	265152	Restraining Lug	2
3	265154	Restraining Lug Spacer	2
4	211074	Bolt	4
5	210411	Lockwasher	4
6	211720	Hex Nut	4
7	210999	Bolt	4
8	210410	Lockwasher	4
9	211661	Hex Nut	4
10	280059	2-Wheel Trolley Flanged Wheels, 3.33" Operating Flange, 5000# Truck Capacity	2
	280481	Flangeless Wheels, 3.33" Operating Flange, 5000# Truck Capacity	
	280067	Flanged Wheels, 3.33" Operating Flange, 10000# Truck Capacity	
	280491	Flangeless Wheels, 3.33" Operating Flange, 10000# Truck Capacity	

No Recommended Spare Parts

PARTS LIST – END TRUCK ASSEMBLY

8-WHEEL SUPERTRACK™ END TRUCK ASSEMBLY FOR RUBBER TIRE DRIVE 20000# TRUCK CAPACITY 6'- 0" WHEEL BASE 3.33" OPERATING FLANGE

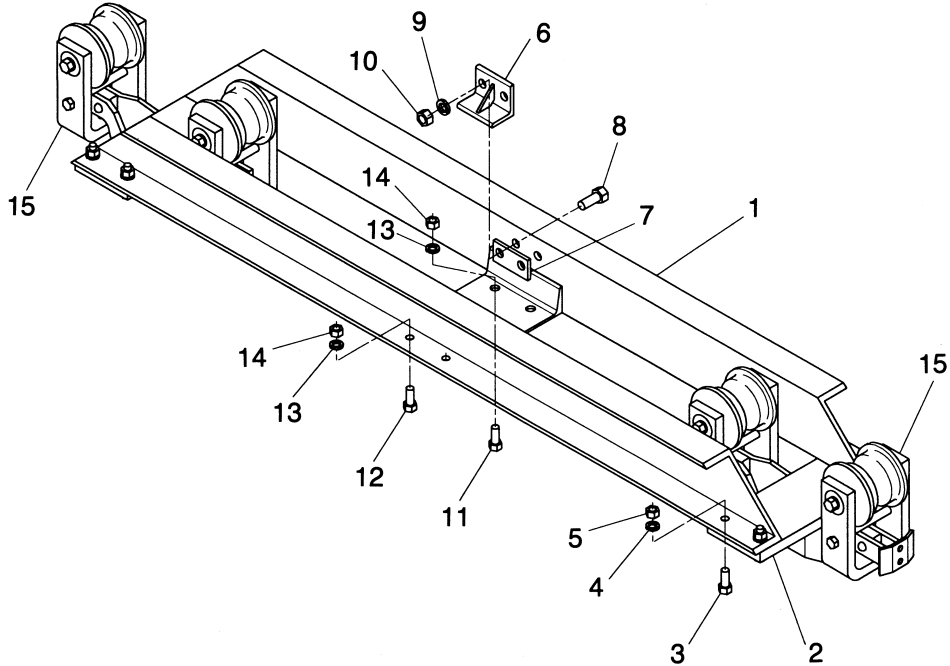

END TRUCK ASSEMBLY PARTS

ITEM NO.	PART NUMBER	DESCRIPTION	QTY
1	260523	Frame	1
2	260303	Trolley Adapter (a)	2
3	211001	Bolt (a)	8
4	210410	Lockwasher (a)	8
5	211661	Hex Nut (a)	8
6	265153	Restraining Lug	2
7	265154	Restraining Lug Spacer	2
8	211074	Bolt	4
9	210411	Lockwasher	4
10	211720	Hex Nut	4
11	210999	Bolt	4
12	211000	Bolt	4
13	210410	Lockwasher	8
14	211661	Hex Nut	8
15	280664 301650	4-Wheel Trolley Flanged Wheels, 3.33" Operating Flange, 10000# Capacity Flangeless Wheels, 3.33" Operating Flange, 10000# Capacity	2

No Recommended Spare Parts

NOTE:

(a) Included with item no. 1, but also available as a spare.

PARTS LIST – END TRUCK ASSEMBLY

4-WHEEL TROJANTRACK™ END TRUCK ASSEMBLY FOR RUBBER TIRE DRIVE 15000# TRUCK CAPACITY 6'- 0" WHEEL BASE 3.33" OPERATING FLANGE

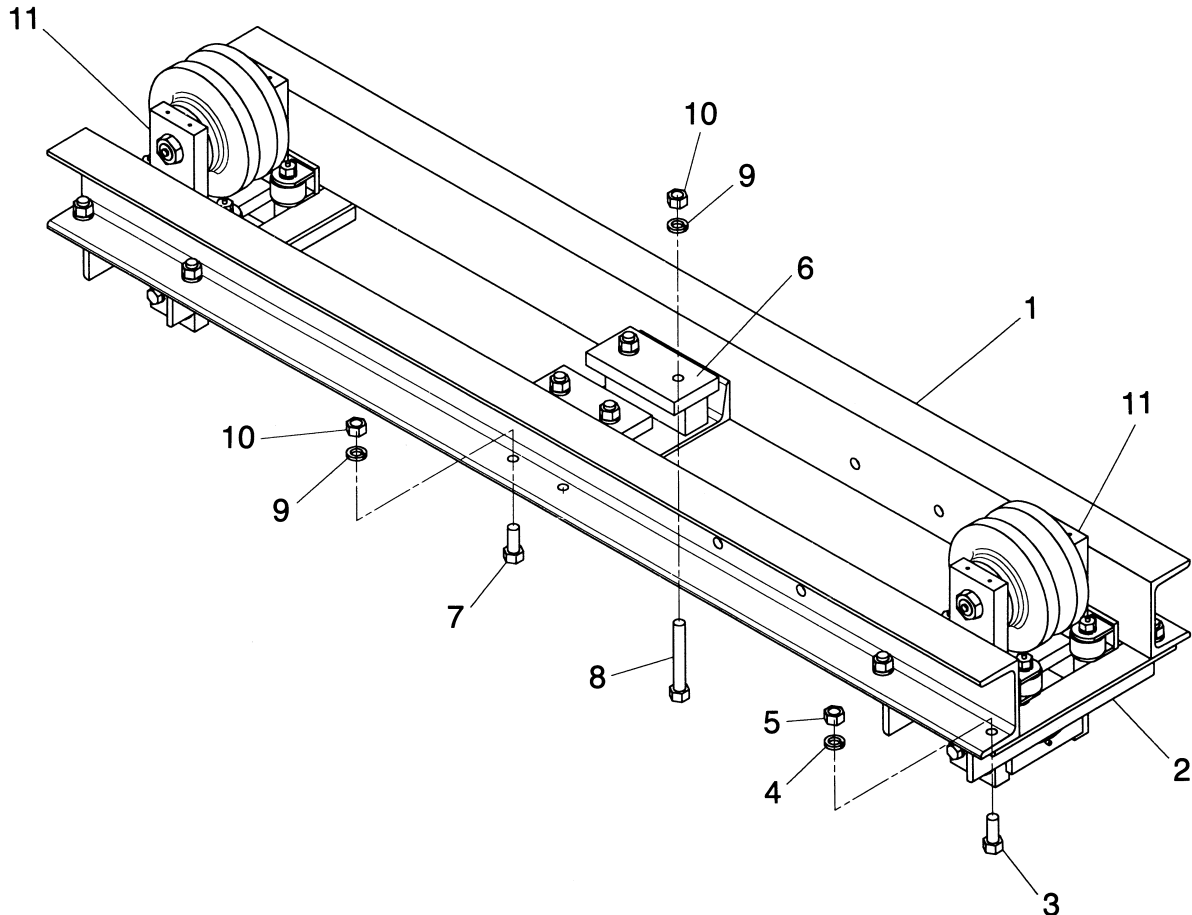

END TRUCK ASSEMBLY PARTS

ITEM NO.	PART NUMBER	DESCRIPTION	QTY
1	410387	Frame	1
2	300088	Trolley Adapter (a)	2
3	210999	Bolt (a)	8
4	210410	Lockwasher (a)	8
5	211661	Hex Nut (a)	8
6	410386	Restraining Lug (Pair)	1
7	211001	Bolt	4
8	211009	Bolt	4
9	210410	Lockwasher	8
10	211661	Hex Nut	8
11	280494	2-Wheel Trolley	2

No Recommended Spare Parts

NOTE:

(a) Included with item no. 1, but also available as a spare.

PARTS LIST – END TRUCK ASSEMBLY

8-WHEEL TROJANTRACK™ END TRUCK ASSEMBLY FOR RUBBER TIRE DRIVE 30000# AND 40000# TRUCK CAPACITY 6'- 0" WHEEL BASE 3.33" OPERATING FLANGE

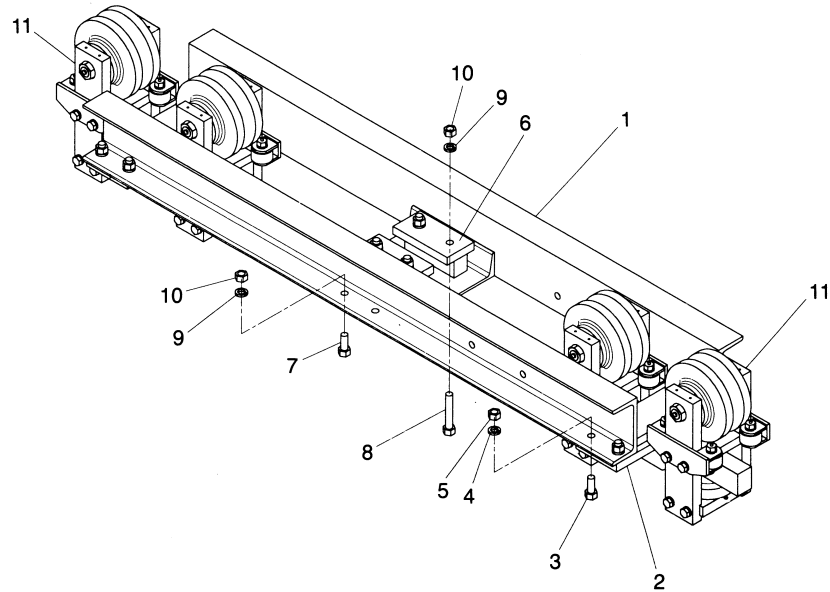

END TRUCK ASSEMBLY PARTS

ITEM NO.	PART NUMBER	DESCRIPTION	QTY
1	410383 410384	Frame 30000# Truck Capacity 40000# Truck Capacity	1
2	260501	Trolley Adapter (a)	2
3	211075 211076	Bolt (a) 30000# Truck Capacity 40000# Truck Capacity	8
4	210411	Lockwasher (a)	8
5	211720	Hex Nut (a)	8
6	410386	Restraining Lug (Pair)	1
7	211075 211142	Bolt 30000# Truck Capacity 40000# Truck Capacity	4
8	211085 211152	Bolt 30000# Truck Capacity 40000# Truck Capacity	4
9	210411 210412	Lockwasher 30000# Truck Capacity 40000# Truck Capacity	8
10	211720 211771	Hex Nut 30000# Truck Capacity 40000# Truck Capacity	8
11	265160	4-Wheel Trolley	2

No Recommended Spare Parts

NOTE:

(a) Included with item no.1, but also available as a spare.

PARTS LIST – TROLLEY ASSEMBLY

2-WHEEL SUPERTRACK™ TROLLEY ASSEMBLY FLANGED WHEELS 1500# TROLLEY CAPACITY 2.0" AND 3.33" OPERATING FLANGE

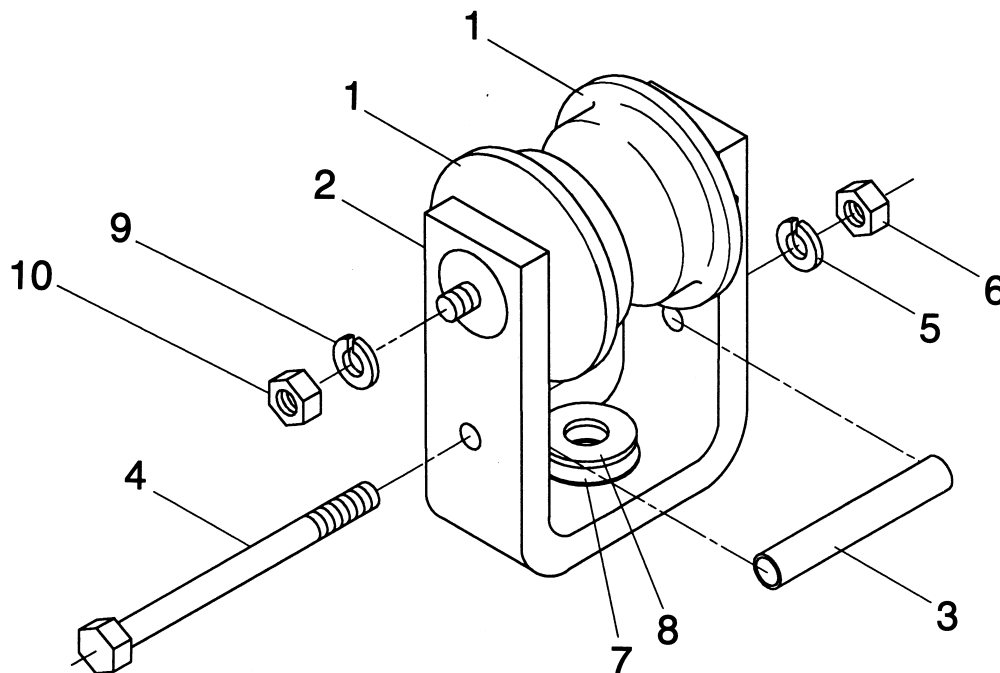

COMPLETE TROLLEY ASSEMBLY
Part No. 280027: 2.0" operating flange.
Part No. 280056: 3.33" operating flange.

TROLLEY ASSEMBLY PARTS

ITEM NO.	PART NUMBER	DESCRIPTION	QTY
1▲	280877 280878	Wheel Assembly 2" Operating Flange 3.33" Operating Flange	2
2	260120 260195	Trolley Yoke 2.0" Operating Flange 3.33" Operating Flange	1
3	260121 260206	Yoke Spacer 2.0" Operating Flange 3.33" Operating Flange	1
4	210938 210939	Yoke Spacer Bolt 2.0" Operating Flange 3.33" Operating Flange	1
5	210409	Lockwasher	1
6	211609	Hex Nut	1
7▲	213612	T-2301-4 Thrust Bearing	1
8▲	260194	Steel Bearing Washer	1
9	210411	Lockwasher (a)	2
10	211716	Hex Nut (a)	2

▲Recommended Spare Parts

NOTE:

(a) Included with item no.1, but also available as a spare.

PARTS LIST – TROLLEY ASSEMBLY

2-WHEEL SUPERTRACK™ TROLLEY ASSEMBLY FLANGELESS WHEELS AND GUIDE ROLLERS 1500# TROLLEY CAPACITY 2.0" AND 3.33" OPERATING FLANGE

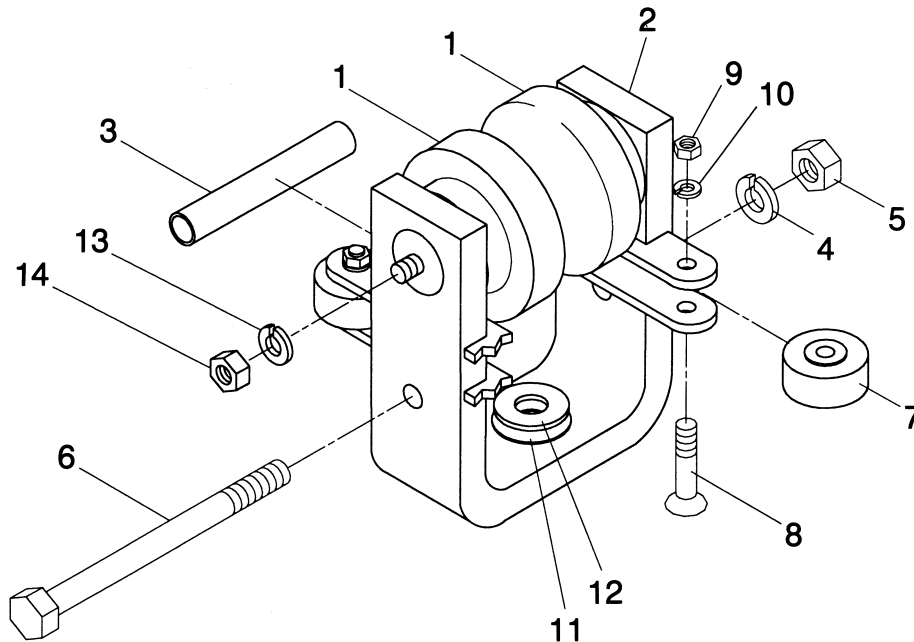

COMPLETE TROLLEY ASSEMBLY
Part No. 280474: 2.0" operating flange.
Part No. 280480: 3.33" operating flange.

TROLLEY ASSEMBLY PARTS

ITEM NO.	PART NUMBER	DESCRIPTION	QTY
1▲	280879	Wheel Assembly	2
2	265002 265003	Trolley Yoke 2.0" Operating Flange 3.33" Operating Flange	1
3	260121 260206	Yoke Spacer 2.0" Operating Flange 3.33" Operating Flange	1
4	210409	Lockwasher	1
5	211609	Hex Nut	1
6	210930	Yoke Spacer Bolt	1
7▲	213674	Guide Roller	4
8	212547	Flat Head Machine Screw	4
9	211547	Hex Nut	4
10	210407	Lockwasher	4
11▲	213612	T-2301-4 Thrust Bearing	1
12▲	260194	Steel Bearing Washer	1
13	210411	Lockwasher (a)	2
14	211716	Hex Nut (a)	2

▲Recommended Spare Parts

NOTE:

(a) Included with item no. 1, but also available as a spare.

PARTS LIST – TROLLEY ASSEMBLY

2-WHEEL SUPERTRACK™ TROLLEY ASSEMBLY FLANGED WHEELS 2500# AND 5000# TROLLEY CAPACITY 3.33" OPERATING FLANGE

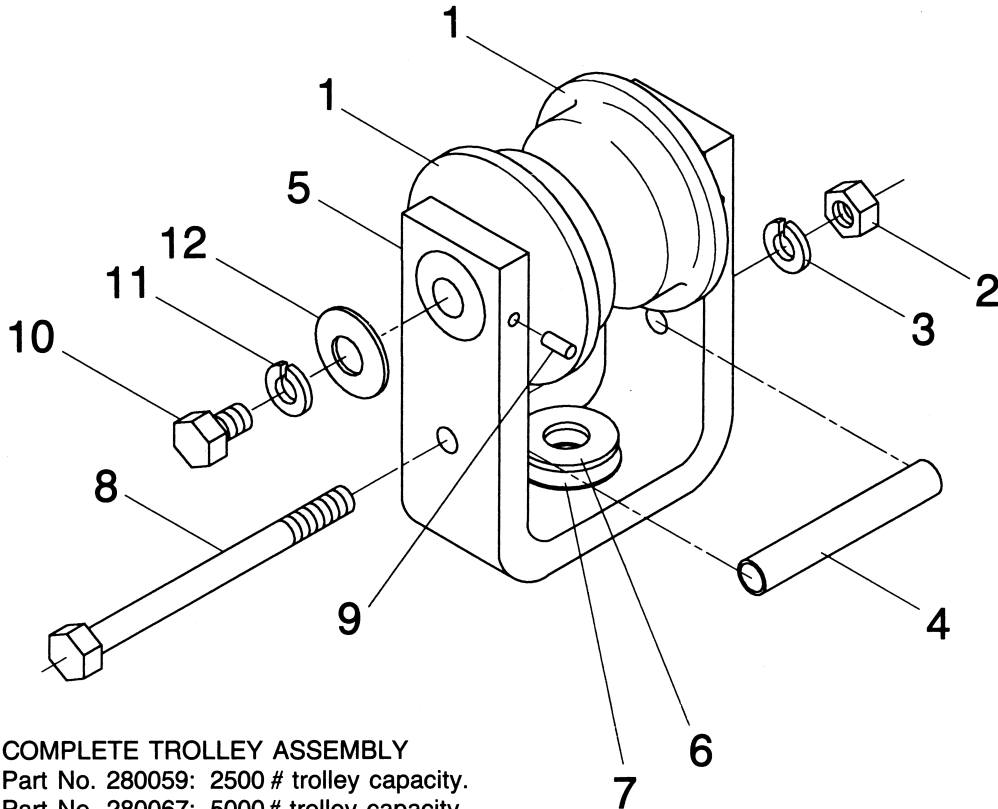

COMPLETE TROLLEY ASSEMBLY
Part No. 280059: 2500 # trolley capacity.
Part No. 280067: 5000# trolley capacity.

TROLLEY ASSEMBLY PARTS

ITEM NO.	PART NUMBER	DESCRIPTION	QTY
1▲	280882 280593	Wheel Assembly, 4½ diameter 2500# Trolley Capacity 5000# Trolley Capacity	2
2	211661	Hex Nut	1
3	210410	Lockwasher	1
4	260132	Yoke Spacer	1
5	260131	Trolley Yoke	1
6▲	260194	Steel Bearing Washer	1
7▲	213612	T-2301-4 Thrust Bearing	1
8	211014	Spacer Bolt	1
9	213482	Roll Pin	2
10	260049	Screw Assembly (a)	2
11	210410	Lockwasher (a)	2
12	260434	Washer (a)	1

▲Recommended Spare Parts

NOTE:

(a) Included with item no. 1, but also available as a spare.

PARTS LIST – TROLLEY ASSEMBLY

2-WHEEL SUPERTRACK™ TROLLEY ASSEMBLY FLANGELESS WHEELS AND GUIDE ROLLERS 2500# AND 5000# TROLLEY CAPACITY 3.33" OPERATING FLANGE

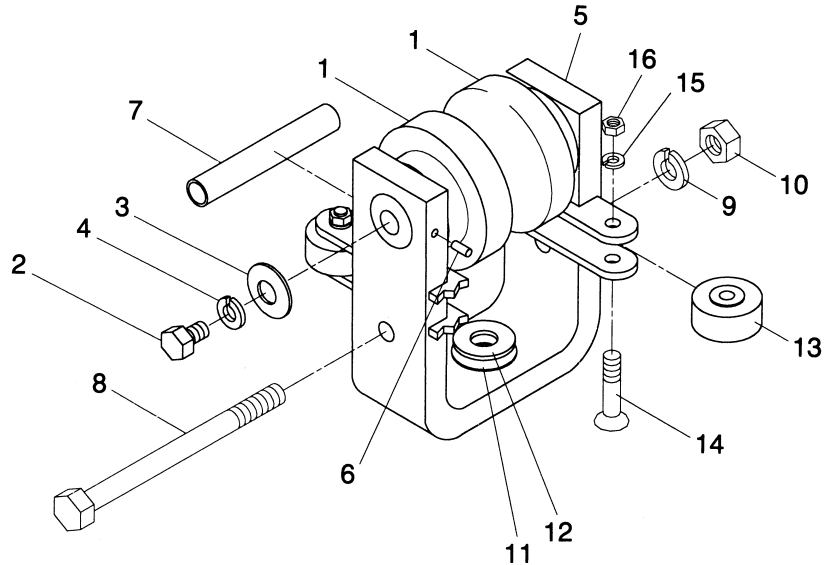

COMPLETE TROLLEY ASSEMBLY

Part No. 280481: 2500# trolley capacity.

Part No. 280491: 5000# trolley capacity.

TROLLEY ASSEMBLY PARTS

ITEM NO.	PART NUMBER	DESCRIPTION	QTY
1▲	280881 280595	Wheel Assembly, 4½ diameter 2500# Trolley Capacity 5000# Trolley Capacity	2
2	260049	Screw Assembly (a)	2
3	260434	Washer (a)	2
4	210410	Lockwasher (a)	2
5	260519	Trolley Yoke	1
6	213482	Roll Pin	2
7	260132	Yoke Spacer	1
8	211014	Spacer Bolt	1
9	210410	Lockwasher	1
10	211661	Hex Nut	1
11▲	213612	T-2301-4 Thrust Bearing	1
12▲	260194	Steel Bearing Washer	1
13▲	213674	Guide Roller	4
14	212547	Flat Head Machine Screw	4
15	210407	Lockwasher	4
16	211547	Hex Nut	4

▲Recommended Spare Parts

NOTE:

(a) Included with item no. 1, but also available as a spare.

PARTS LIST – TROLLEY ASSEMBLY

4-WHEEL SUPERTRACK™ TROLLEY ASSEMBLY FLANGED WHEELS FLANGELESS WHEELS AND GUIDE ROLLERS FOR HAND-PROPELLED CRANES 3000# AND 5000# TROLLEY CAPACITY 2.0" AND 3.33" OPERATING FLANGE

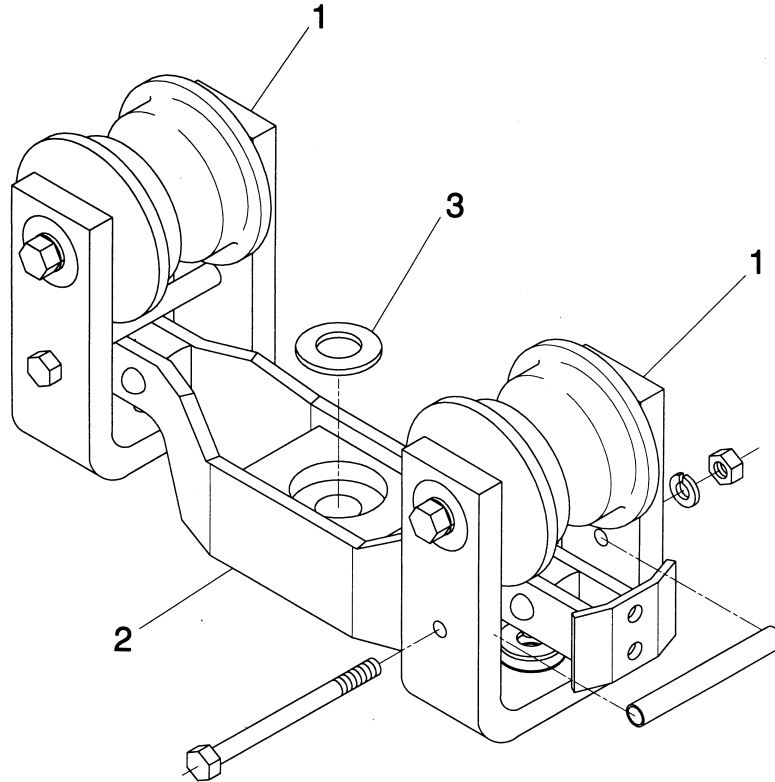

COMPLETE TROLLEY ASSEMBLY

- Part No. 301226: 3000# trolley capacity, 4" diameter flanged wheels, 2.0" operating flange.
- Part No. 301654: 3000# trolley capacity, 4" diameter flangeless wheels, 2.0" operating flange.
- Part No. 280663: 5000# trolley capacity, 4½" diameter flanged wheels, 3.33" operating flange.
- Part No. 301655: 5000# trolley capacity, 4½" diameter flangeless wheels, 3.33" operating flange.

TROLLEY ASSEMBLY PARTS

ITEM NO.	PART NUMBER	DESCRIPTION	QTY
1	280027	2-Wheel Trolley, 4" diameter, flanged wheels, 2.0" operating flange.	2
	280474	4" diameter, flangeless wheels, 2.0" operating flange.	
	280059	4½" diameter, flanged wheels, 3.33" operating flange.	
	280481	4½" diameter, flangeless wheels, 3.33" operating flange.	
2	260247	Loadbar Assembly	1
3▲	213613	T-2304 Thrust Bearing (a)	1

▲Recommended Spare Parts

NOTE:

(a) Included with item no.2, but also available as a spare.

PARTS LIST – TROLLEY ASSEMBLY

4-WHEEL SUPERTRACK™ TROLLEY ASSEMBLY FLANGED WHEELS AND FLANGELESS WHEELS WITH GUIDE ROLLERS FOR MOTOR-DRIVEN CRANES 10000# TROLLEY CAPACITY 3.33" OPERATING FLANGE

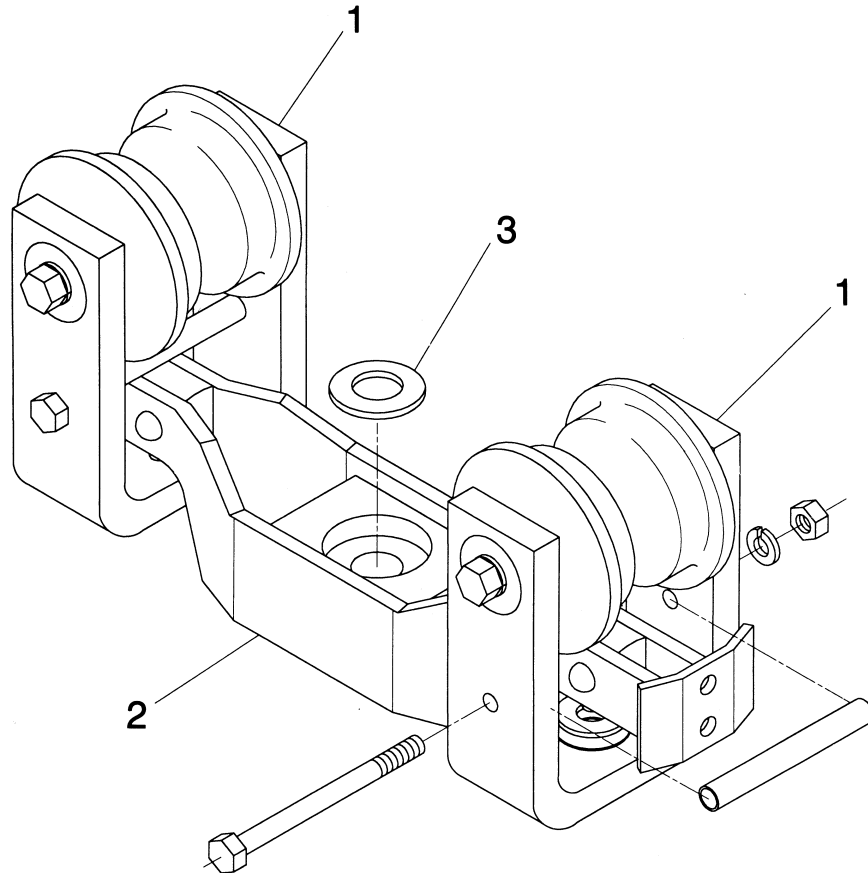

COMPLETE TROLLEY ASSEMBLY

Part No. 280664: 10000 # trolley capacity, 4½" diameter flanged wheels, 3.33" operating flange.

Part No. 301650: 10000 # trolley capacity, 4½" diameter flangeless wheels, 3.33" operating flange.

TROLLEY ASSEMBLY PARTS

ITEM NO.	PART NUMBER	DESCRIPTION	QTY
1▲	280067 280491	2-Wheel Trolley, 4½" diameter, flanged wheels, 3.33" operating flange. 4½" diameter, flangeless wheels, 3.33" operating flange.	2
2	260247	Loadbar Assembly	1
3▲	213613	T-2304 Thrust Bearing (a)	1

▲Recommended Spare Parts

NOTE:

(a) Included with item no.2, but also available as a spare.

PARTS LIST – TROLLEY ASSEMBLY

4-WHEEL SUPERTRACK™ TROLLEY ASSEMBLY FLANGED WHEELS AND FLANGELESS WHEELS WITH GUIDE ROLLERS FOR STEEL WHEEL DRIVE 10000# TROLLEY CAPACITY 3.33" OPERATING FLANGE

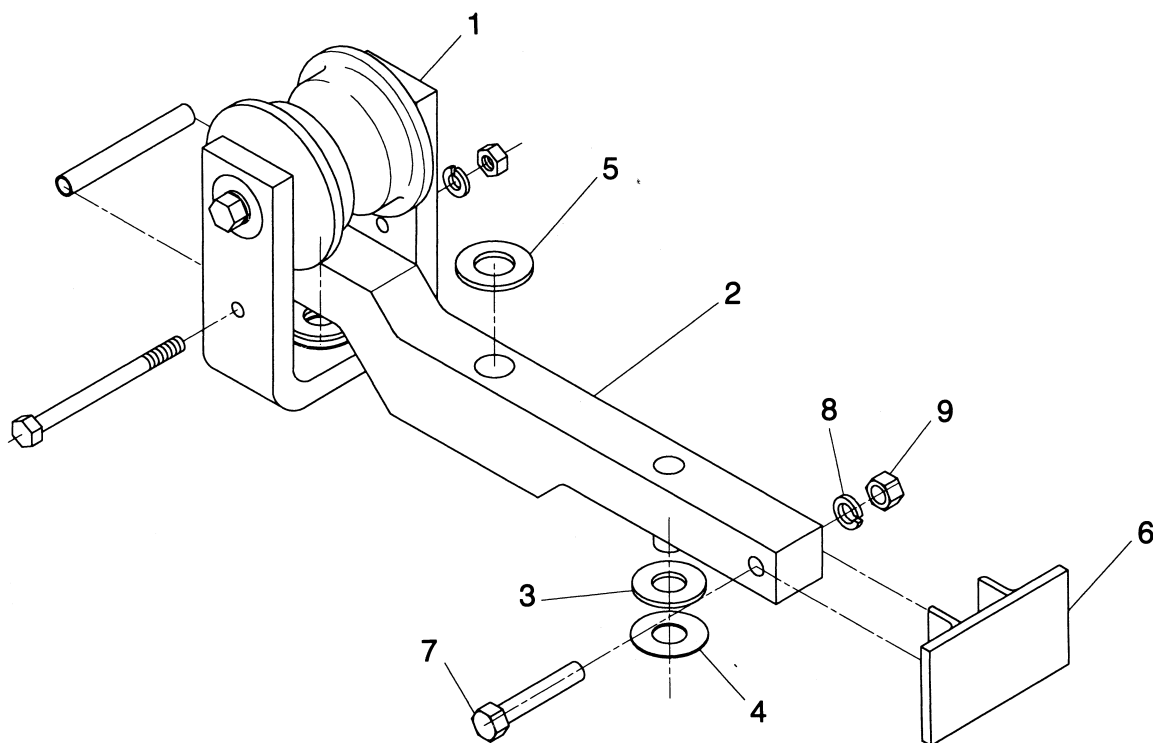

COMPLETE TROLLEY ASSEMBLY

Part No. 280667: 10000 # trolley capacity, 4½" diameter flanged wheels, 3.33" operating flange.

Part No. 301651: 10000 # trolley capacity, 4½" diameter flangeless wheels, 3.33" operating flange.

TROLLEY ASSEMBLY PARTS

ITEM NO.	PART NUMBER	DESCRIPTION	QTY
1	280067 280491	2-Wheel Trolley, 4½" diameter, flanged wheels, 3.33" operating flange. 4½" diameter, flangeless wheels, 3.33" operating flange.	1
2	265170	Loadbar	1
3▲	260194	Steel Bearing Washer	1
4▲	213612	T-2301-4 Thrust Bearing	1
5▲	213613	T-2304 Thrust Bearing	1
6	260119	Loadbar Bumper	1
7	211005	Hex Head Bolt	1
8	210410	Lockwasher	1
9	211661	Hex Nut	1

▲Recommended Spare Parts

PARTS LIST – TROLLEY ASSEMBLY

2-WHEEL TROJANTRACK™ TROLLEY ASSEMBLY FLANGELESS WHEELS WITH GUIDE ROLLERS 10000# TROLLEY CAPACITY 3.33" OPERATING FLANGE

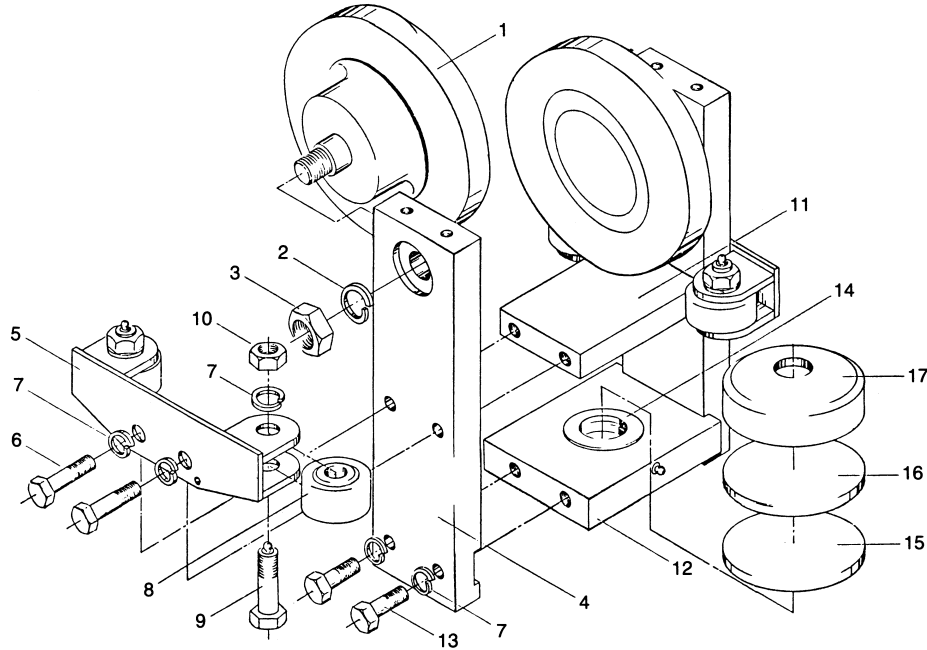

COMPLETE TROLLEY ASSEMBLY

Part No. 280494: 10000 # trolley capacity, flangeless wheels, 3.33" operating flange.

TROLLEY ASSEMBLY PARTS

ITEM NO.	PART NUMBER	DESCRIPTION	QTY
1▲	280589	Wheel, Axle, and Bearing Assembly	2
2	210414	Lockwasher	2
3	211882	Hex Jam Nut	2
4	260314	Trolley Side Bar	2
5	260313	Guide Roller Bracket	2
6	211001	Hex Head Bolt	4
7	210410	Lockwasher	12
8▲	213689	Guide Roller	4
9▲	260307	Guide Roller Axle	4
10	211664	Hex Nut	4
11	260312	Upper Cross Bar	1
12	260311	Lower Cross Bar	1
13	210998	Hex Head Bolt	4
14▲	213531	Thrust Bearing	1
15	260309	Thrust Bearing Plate	1
16▲	213151	Rubber Absorber	1
17	260310	Shock Absorber Housing	1

▲Recommended Spare Parts

PARTS LIST – TROLLEY ASSEMBLY

4-WHEEL TROJANTRACK™ TROLLEY ASSEMBLY FLANGELESS WHEELS WITH GUIDE ROLLERS 20000# TROLLEY CAPACITY 3.33" OPERATING FLANGE

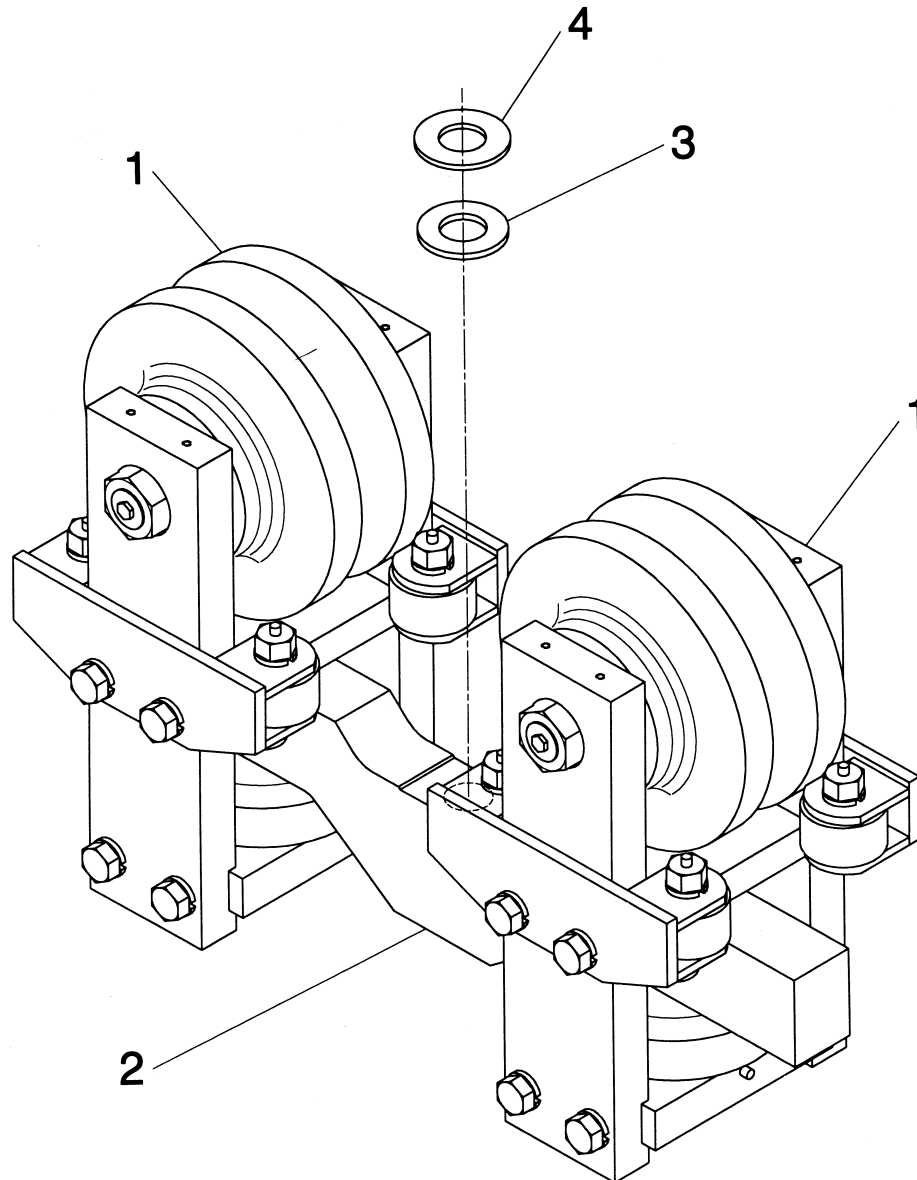

COMPLETE TROLLEY ASSEMBLY

Part No. 265160: 20000 # trolley capacity, flangeless wheels, 3.33" operating flange.

TROLLEY ASSEMBLY PARTS

ITEM NO.	PART NUMBER	DESCRIPTION	QTY
1	280494	2-Wheel Trolley	2
2	265161	Loadbar Assembly	1
3▲	213613	T-2304 Thrust Bearing	1
4▲	210238	Washer	1

▲Recommended Spare Parts

**THIS PAGE INTENTIONALLY
LEFT BLANK**

PARTS LIST – CRANE CONTROL

SINGLE AND TWO-SPEED BRIDGE CONTROL

CONTROL PANEL ASSEMBLY

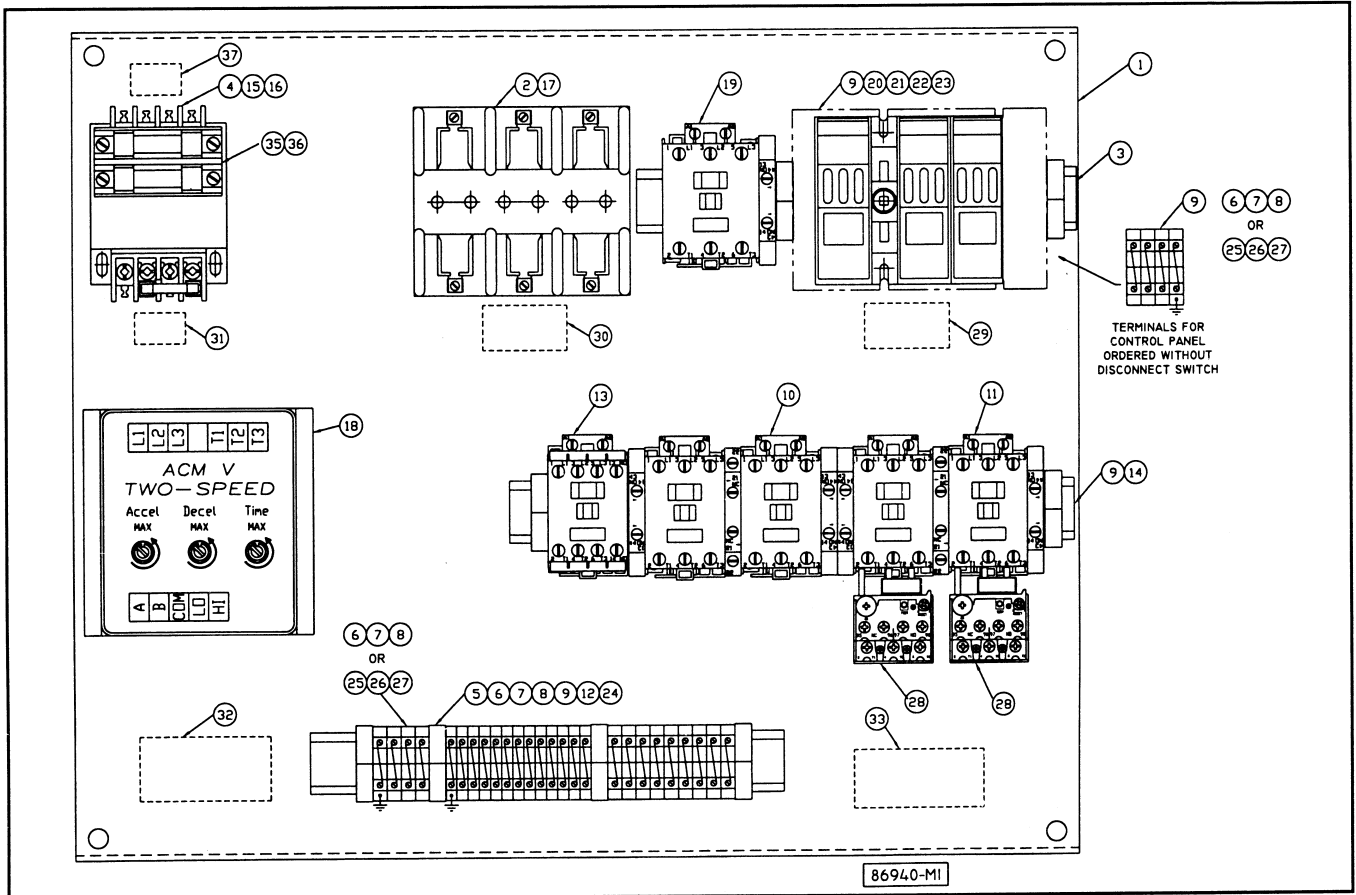

DISCONNECT SWITCH ASSEMBLY

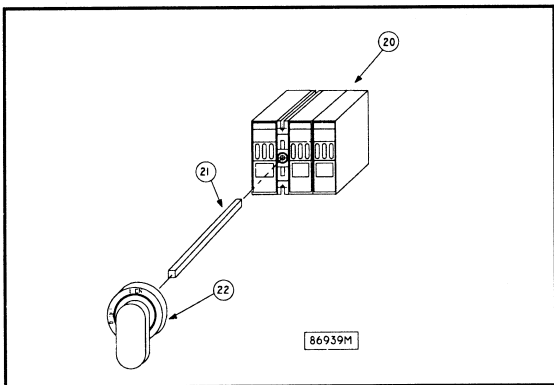

CONTROL ENCLOSURE

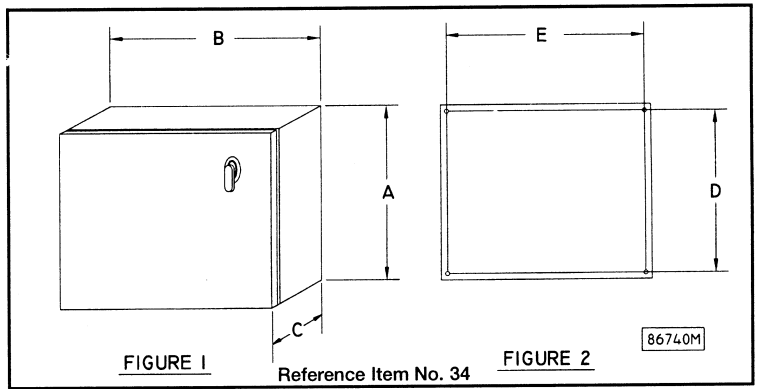

ENCLOSURE MOUNTING HARDWARE

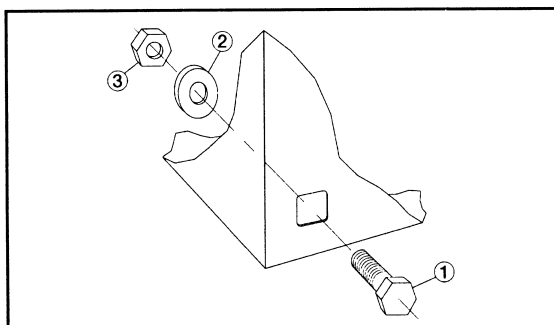

Enclosure mounting hardware (included) consists of (4) bolts (item 1), (4) sealing washers (item 2), and (4) nuts (item 3). Tighten to 180 inch pounds.

ENCLOSURE DIMENSIONS (figure 1)

A	B	C
20 inches	24 inches	8 inches

ENCLOSURE MOUNTING DIMENSIONS (figure 2)

D	E	MOUNTING HOLE DIA.
18.5 inches	22.5 inches	7/16 inches

PARTS LIST – CRANE CONTROL

SINGLE AND TWO-SPEED BRIDGE CONTROL

REPLACEMENT PARTS FOR SINGLE AND TWO-SPEED CONTROL PANELS

ITEM	P/N	DESCRIPTION
1	86836	Panel, Component Mounting
2	PA7341	Fuse Block, Bridge Motor Circuit
3	86714-03	Din Rail, 9-1/2" Long
4	52429-80	Fuse Holder, Transformer
5	86710-01	Terminal, Control
6	86710-02	Terminal, Power
7	86710-04	Terminal, Grounding
8	86710-06	Terminal End Barrier, Power
9	86710-05	Terminal End Anchor
▲10	86727-01	Contactora, Reversing, Size B
	86729-01	Contactora, Reversing, Size C
▲11	86727-01	Contactora, Two-Speed, Size B (see note)
	86729-01	Contactora, Two-Speed, Size C (see note)
12	PA7556	Din Rail, Elevated, 10-1/2" Long
13	86737-03	Relay, Control (two-speed only)
14	86714-10	Din Rail, 12-1/2" Long
▲15	PA7329	Transformer Fuse, (for 100 VA)
	PA6333	Transformer Fuse, (for 200 VA)
16	52429-04	Transformer, 200-115 V. (100 VA)
	52429-16	Transformer, 230/460-115 V. (100 VA)
	52429-39	Transformer, 575-115 V. (100 VA)
	52429-06	Transformer, 200-115 V. (200 VA)
	52429-18	Transformer, 230/460-115 V. (200 VA)
52429-41	Transformer, 575-115 V. (200 VA)	
▲17	86709-XXX	Fuse, Bridge Motor Circuit (see notes)
18	86715-017	ACM, S.S. 1 H.P. @ 200-230 V. 2 H.P. @ 460 V.
	86715-018	ACM, 2SP 1 H.P. @ 200-230 V. 2 H.P. @ 460 V.
	86715-002	ACM, S.S. 2 H.P. @ 575 V.
	86715-006	ACM, 2 SP 2 H.P. @ 575 V.

ITEM	P/N	DESCRIPTION
18	86715-019	ACM S.S. 2.5 H.P. @ 200-230 V. 5 H.P. @ 460 V.
	86715-020	ACM 2SP 2.5 H.P. @ 200-230 V. 5 H.P. @ 460 V.
	86715-004	ACM S.S. 5 H.P. @ 575 V.
	86715-008	ACM 2SP 5 H.P. @ 575 V.
19	86733-01	Mainline Contactor, Size C
	86734-01	Mainline Contactor, Size D
20	PA7649	Fusible Disc. Switch, 30 A.
	PA7650	Fusible Disc. Switch, 60 A.
21	PA7651	Disc. Switch Operating Rod, 30 A.
	PA7652	Disc. Switch Operating Rod, 60 A.
22	PA7653	Disc. Switch Operating Handle
▲23	86709-300	Fuse, Disc. Switch, 30 A.
	86709-600	Fuse, Disc. Switch, 60 A.
24	86710-07	Terminal End Barrier, Control
25	86710-03	Terminal, Power Connection
26	86710-08	Terminal End Barrier, Power Connection
27	86710-11	Terminal, Grounding, Power Connection
28	86736-XX	Overload Relay, Optional (see note)
29	71380	Label, Fuse I.D., Disconnect Switch
30	70726	Label, Fuse I.D., Motor Circuit
31	70266	Label, Fuse I.D., Transformer
32	71379	Nameplate
33	69505-02	Label, Danger, Electrical
34	86740-01	Enclosure, NEMA 12
	86740-02	Enclosure, NEMA 4
35	52429-81	Fuse Block, Transformer
▲36	86724-XXX	Fuse, Transformer Primary (see chart below)
37	71399	Label, Fuse I.D., Transformer Primary

▲ Denotes Recommended Spare Parts

NOTES:

- (1) When ordering replacement fuses or overload relays, provide fuse or overload relay amperage rating and/or total full load amperage of all bridge motors and the operating (line) voltage.
- (2) Two-speed contactors are provided as reversing contactors. Remove load (bottom) side power jumpers to use as two-speed contactors.
- (3) When control is provided without fusible disconnect switch (item 20, 21, 22, and 23), power terminals are provided in their place.
- (4) Parts list is not unique. Not all parts are required for every control panel.

CONTROL PANEL RATING

LINE VOLTAGE	200 V.	230 V.	460 V.	575 V.
Size "B" Control w/ ACM	1 H.P.	1 H.P.	2 H.P.	2 H.P.
Size "B" Control w/o ACM	2 H.P.	2 H.P.	5 H.P.	5 H.P.
Size "C" Control w/ ACM	2.5 H.P.	2.5 H.P.	5 H.P.	5 H.P.
Size "C" Control w/o ACM	7.5 H.P.	7.5 H.P.	10 H.P.	25 H.P.

TRANSFORMER PRIMARY FUSE, ITEM 36

FUSE P/N (ITEM 36)	USE WITH TRANSFORMER P/N
86724-005	52429-16 when connected @ 460 V, 52429-39, and 52429-41
86724-012	52429-04, 52429-16 when connected @ 230 V, and 52429-18 when connected at 460 V.
86724-020	52429-06 and 52429-18 when connected @ 230 V.

PARTS LIST – CRANE CONTROL

VARIABLE FREQUENCY INVERTER, BRIDGE CONTROL

CONTROL PANEL ASSEMBLY

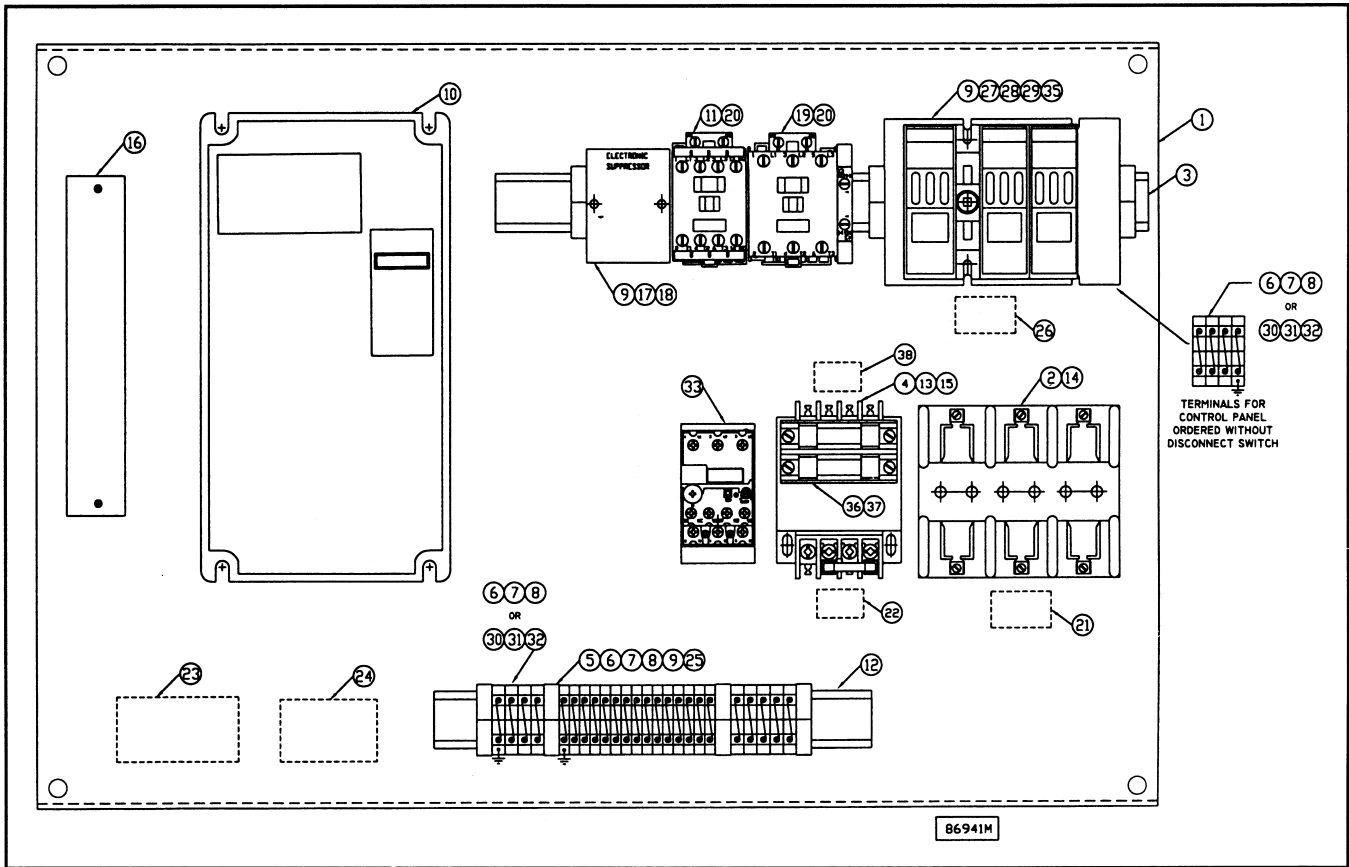

DISCONNECT SWITCH ASSEMBLY

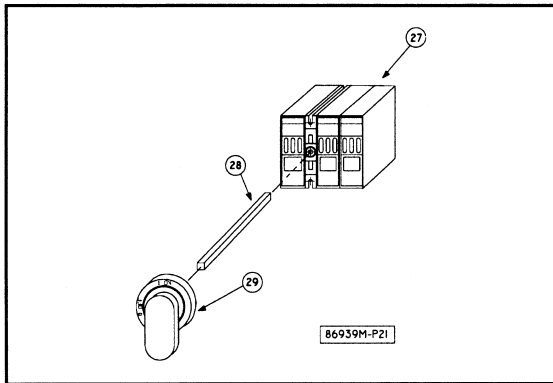

CONTROL ENCLOSURE

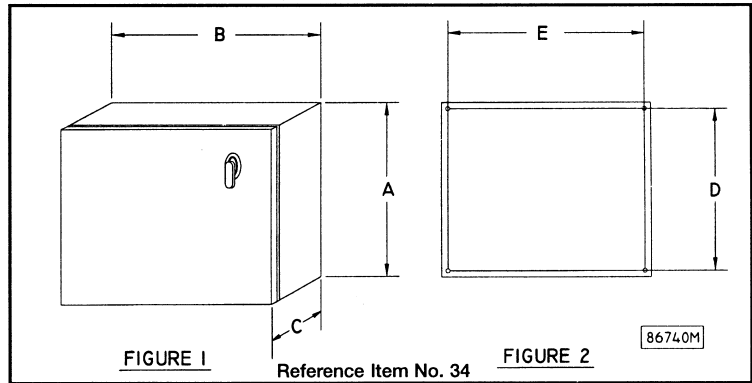

INVERTER BRAKING RESISTORS

BRAKING RESISTOR ASSY. P/N

VOLTS	USE WITH	CMAA CLASS C	CMAA CLASS D
460	86738-41	86739-05	86739-16*
	86738-42	86739-06	86739-17*
	86738-43	86739-07	86739-18*
	86735-45	86739-08	86739-19*
	86738-47	86739-09*	86739-20*
230	86738-21	86739-01	86739-12*
	86738-22	86739-02	86739-13*
	86738-23	86739-03	86739-14*
	86738-25	86739-04	86739-15*

* Denotes resistor assy's. that mount externally to control enclosure.

ENCLOSURE DIMENSIONS (figure 1)

A	B	C
20 inches	30 inches	8 inches

ENCLOSURE MOUNTING DIMENSIONS (figure 2)

D	E	MOUNTING HOLE DIA.
18.5 inches	28.5 inches	7/16 inches

PARTS LIST – CRANE CONTROL

VARIABLE FREQUENCY INVERTER, BRIDGE CONTROL

REPLACEMENT PARTS FOR INVERTER CONTROLLED BRIDGE PANEL

ITEM	P/N	DESCRIPTION
1	86837	Panel, Component Mounting
2	PA7341	Fuse Block, Bridge Motor Circuit
3	86714-08	Din Rail, 16 in. Long
4	52429-80	Fuse Holder, Transformer
5	86710-01	Terminal, Control
6	86710-02	Terminal, Power
7	86710-04	Terminal, Grounding
8	86710-06	Terminal End Barrier, Power
9	86710-05	Terminal End Anchor
10	86738-41	Inverter Drive, 460 V. 1.9 A. Max.
	86738-42	Inverter Drive, 460 V. 3.6 A. Max.
	86738-43	Inverter Drive, 460 V. 5.1 A. Max.
	86738-45	Inverter Drive, 460 V. 8.5 A. Max.
	86738-47	Inverter Drive, 460 V. 11.7 A. Max.
	86738-21	Inverter Drive, 230 V. 6 A. Max.
	86738-22	Inverter Drive, 230 V. 8 A. Max.
	86738-23	Inverter Drive, 230 V. 11 A. Max.
86738-25	Inverter Drive, 230 V. 17.5 A. Max.	
11	86737-05	Relay, Brake Control
12	PA7556	Din Rail, Elevated, 10-1/2" Long
▲ 13	PA7329	Fuse, Transformer (use with 100 VA)
	PA6333	Fuse, Transformer (use with 200 VA)
▲ 14	86709-030	Fuse, Motor Ckt. Use w/ P/N: 86738-41
	86709-060	Fuse, Motor Ckt. Use w/ P/N: 86738-42
	86709-080	Fuse, Motor Ckt. Use w/ P/N: 86738-43
	86709-100	Fuse, Motor Ckt. Use w/ P/N: 86738-21
	86709-120	Fuse, Motor Ckt. Use w/ P/N: 86738-22
	86709-150	Fuse, Motor Ckt. Use w/ P/N: 86738-45
	86709-200	Fuse, Motor Ckt. Use w/ P/N: 86738-47 and P/N: 86738-23
	86709-250	Fuse, Motor Ckt. Use w/ P/N: 86738-25
15	52429-04	Transformer, 200-115 V. (100 VA)
	52429-16	Transformer, 230/460-115 V. (100 VA)
	52429-39	Transformer, 575-115 V. (100 VA)

ITEM	P/N	DESCRIPTION
15	52429-06	Transformer, 200-115 V. (200 VA)
	52429-18	Transformer, 230/460-115 V. (200 VA)
	52429-41	Transformer, 575-115 V. (200 VA)
16	86739-XX	Inverter D.B. Resistors, see chart
17	PA7606	Suppressor, Brake Coil, 230 V.
	PA7607	Suppressor, Brake Coil, 460 V.
18	PA7608	Din Rail Adapter (460 V. suppressor, qty. 2)
19	86733-01	Contactora, Mainline, "C"
	86734-01	Contactora, Mainline, Size "D"
20	PA7263	Suppressor, Relay Contactora Coil
21	70726	Label, Fuse I.D., Motor Circuit Fuses
22	70266	Label, Fuse I.D., Transformer Fuse
23	71739	Nameplate
24	69505-02	Label, Danger, Electrical
25	86710-07	Terminal End Barrier, Control
26	71380	Label, Fuse I.D., Disc. Switch
27	PA7649	Fusible Disc. Switch, 30 A.
	PA7650	Fusible Disc. Switch, 60 A.
28	PA7651	Disc. Switch Operating Rod, 30 A.
	PA7652	Disc. Switch Operating Rod, 60 A.
29	PA7653	Disc. Switch Operating Handle
30	86710-03	Terminal, Power Connection
31	86710-08	Terminal End Barrier, Power Connection
32	86710-11	Terminal, Grounding, Power Connection
▲ 33	86736-XX	Overload Relay, Optional (see notes)
	86736-50	Overload Relay Mtg. Base (see notes)
34	86740-04	Enclosure, NEMA 12
	86740-05	Enclosure, NEMA 4
▲ 35	86709-300	Fuse, Disc. Switch, 30 A.
	86709-600	Fuse, Disc. Switch, 60 A.
36	52429-81	Fuse Block, Transformer
▲ 37	86724-XXX	Fuse, Transformer Primary (see chart below)
38	71399	Label, Fuse I.D., Transformer Primary

▲ Denotes Recommended Spare Parts

NOTES:

- (1) When ordering replacement fuses or overload relays, provide fuse or overload relay amperage rating and/or total full load amperage of all bridge motors and the operating (line) voltage.
- (2) When control is provided without fusible disconnect switch (item 27, 28, and 29), power terminals are provided in their place.
- (4) Parts list is not unique. Not all parts are required for every control panel.

TRANSFORMER PRIMARY FUSE, ITEM 37

FUSE P/N (ITEM 37)	USE WITH TRANSFORMER P/N
86724-005	52429-16 when connected @ 460 V, 52429-39, and 52429-41
86724-012	52429-04, 52429-16 when connected @ 230 V, and 52429-18 when connected at 460 V.
86724-020	52429-06 and 52429-18 when connected @ 230 V.

PARTS LIST – CRANE CONTROL

PENDANT CONTROL STATION

PENDANT CONTROL STATION PARTS LIST

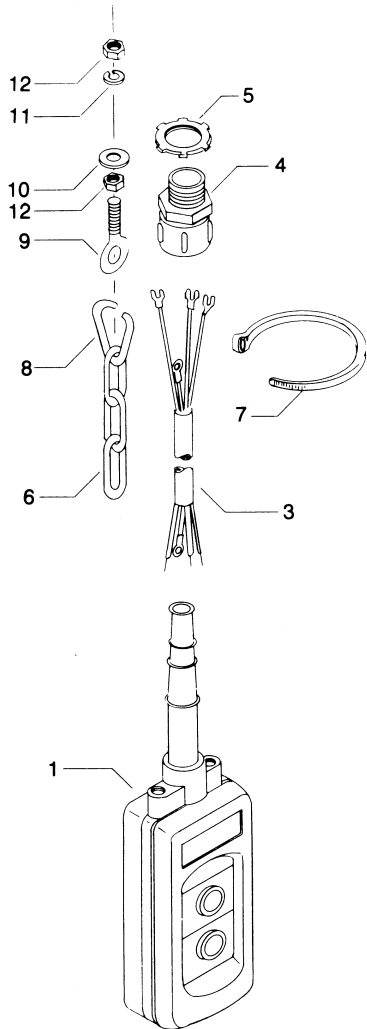

PUSHBUTTON STATION

ITEM NO.	PART NUMBER	DESCRIPTION
1	68898-01	2-Button, Single Speed Pushbutton Station Assembly
	68898-02	2-Button, Two Speed Pushbutton Station Assembly
	86718-02	4-Button, Pushbutton Station, Enclosure only
	86718-03	6-Button, Pushbutton Station Enclosure only
	86718-04	8-Button, Pushbutton Station Enclosure only
2	86718-16	Single Speed Contact Block (not shown)
	86718-19	Two Speed Contact Block (not shown)
	86718-05	Operator Button (Black)
	86718-06	Operator Button (Green)
	86718-07	Operator Button (Red)
3	62046	Cable, 16 Awg., 4 Cond.
	PA2513	Cable, 16 Awg., 8 Cond.
	PA2514	Cable, 16 Awg., 14 Cond.
4	PA2427	Cable Grip, 4 Cond. Cable
	PA2145	Cable Grip, 8 Cond. Cable
	PA2517	Cable Grip, 14 Cond. Cable
5	PA1827	Locknut for PA2427 & PA2145
	PA2036	Locknut for PA2517
6	PA2034	Strain Relief Chain
7	PA6750	Self Locking Tie
8	PA2035	Chain Repair Link
9	PA5037	Eye Bolt
10	15-4-2C	Washer
11	17-4C	Lockwasher
12	22-4C	Nut
13	63178-01	Warning Label

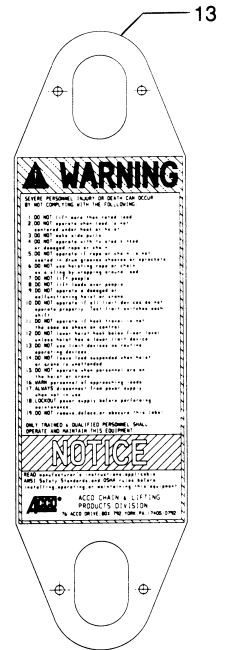

**WARNING LABEL
63178-01
Replace Label
If Lost or Illegible**

NOTE:

When ordering pushbutton control cable or strain relief chain, specify length in feet. When specifying length of control cable, allow sufficient length to make connections inside of pushbutton station and control enclosure.

GENERAL CONDITIONS OF WARRANTY

WARRANTIES: The Seller warrants to the original using Buyer thereof that the goods sold under this Agreement are free from defects in workmanship and materials for a period of one year from the date of shipment to the original using Buyer. No other express warranties are given and no affirmation of Seller or Seller's agents, by word or action, shall constitute a warranty. No warranty is made for components and accessories made by others when such items are warranted by their respective manufacturers.

Installation or operation of the equipment in any manner other than as recommended by Seller, shall void the warranty.

Any variations in details between the goods furnished herein and those covered in Buyer's specifications are due to standards of manufacture not to be construed as exceptions to the specifications.

DISCLAIMER OF IMPLIED WARRANTIES:

- (a) SELLER MAKES NO WARRANTY OF MERCHANTABILITY IN RESPECT TO THE GOODS SOLD UNDER THIS AGREEMENT.
- (b) This sale is made WITHOUT ANY WARRANTY BY SELLER THAT THE GOODS ARE SUITABLE FOR ANY PARTICULAR PURPOSE.
- (c) Buyer hereby waives all other warranties, guarantees, obligations, liabilities, rights, and remedies arising by law or otherwise including any obligation or liability of the Seller arising from tort, and Buyer shall indemnify Seller from any liability, loss, damage, or claim arising from Buyer's tortious use of the goods sold hereby.

REMEDIES:

- (a) Under no conditions shall any goods be returned to Seller without its prior written consent.
- (b) The Buyer's sole and exclusive remedy for breach of any warranty is limited to Seller furnishing, at its expense, duplicate or repaired parts F.O.B. Seller's plant with installation at Buyer's expense if discovery of a claimed defect occurs during the allowable warranty period, and if Seller's inspection determines a defect exists.
- (c) The quantity of material shown by invoice shall in all cases govern settlement for shortages, unless notice of shortage, appropriately documented, is given to the carrier and the Seller upon delivery by the Carrier.
- (d) Claims for errors, deficiencies or imperfections shall be deemed waived by the Buyer unless Seller is notified in writing of the basis of such claims within 10 days after discovery of claimed defect and such discovery occurs within the warranted period.
- (e) Neither Buyer nor User shall be entitled under this Agreement to recover from Seller any incidental or consequential damages of any nature including but not limited to the cost of any labor expended by others in connection with the goods sold hereby by reason of any alleged nonconformity or breach of warranty on the part of the Seller, nor costs of material or account thereof, nor any lost profits whether determinable or speculative.



Acco Chain & Lifting Products Division

76 Acco Drive, Box 792, York, PA 17405-0792
717-741-4863 800-967-7333 Fax 717-741-8572

PART OF THE  FKI GROUP OF COMPANIES

© FKI Industries, Inc. 2003 STU746 1M 12/03 Printed in U.S.A.



**underhung cranes
product series 500**

**installation
operation
maintenance
and parts
manual**

**supplemental instruction and parts manual pages
for 6-1/2 inch diameter wheel trolleys**

**These pages are to be used in conjunction with the pages in manual
69878.**

All warnings in the above listed manual apply to this supplement.

PARTS LIST - TROLLEY ASSEMBLY

2-WHEEL TROLLEY ASSEMBLY
6 1/2" FLANGED WHEELS
7,500 # TROLLEY CAPACITY
3.25" AND 3.33" OPERATING FLANGE WIDTH

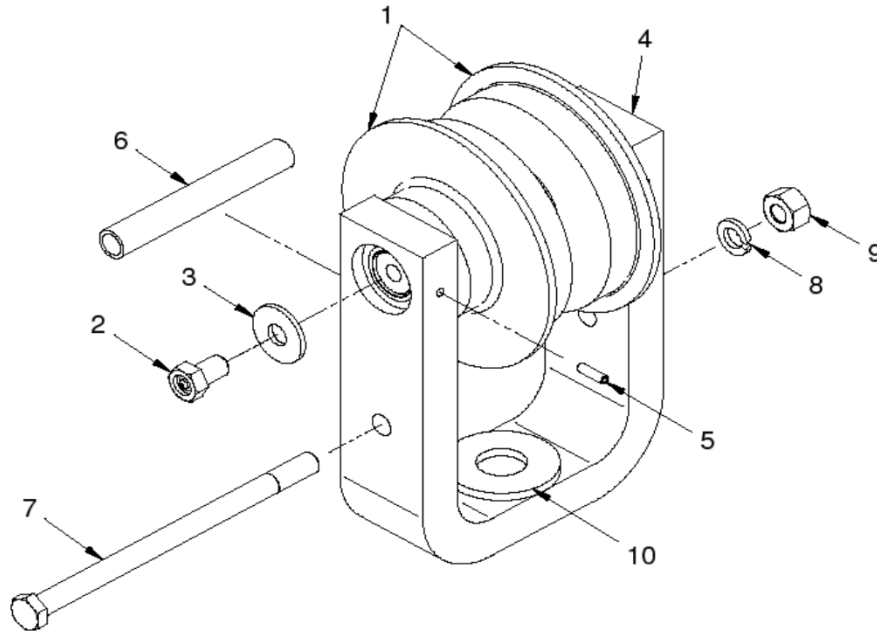

COMPLETE TROLLEY ASSEMBLY:
 Part No. 280314: 7,500 # trolley capacity

TROLLEY ASSEMBLY PARTS

ITEM NO.	PART NUMBER	DESCRIPTION	QTY
1 ▲	280866	Wheel Assembly, 6 1/2" Dia. FLGD for 7,500 LB. Cap. Trolley	2
2 ●	260049	Screw Lube Assembly	2
3 ●	260434	Washer	2
4	260790	Yoke, Trolley	1
5	210021	Pin, Roll	2
6	260225	Spacer, Yoke	1
7	210907	Bolt, Spacer	1
8	210410	Lockwasher	1
9	211661	Nut, Hex	1
10 ▲	260801	Bearing, Thrust	1

NOTE: ▲ Recommended spare parts
 ● Included with item no. 1 but also available as a spare part.

PARTS LIST - TROLLEY ASSEMBLY

4-WHEEL CRANE TROLLEY ASSEMBLY
6 1/2" FLANGELED WHEELS
15,000 # TROLLEY CAPACITY
3.25" AND 3.33" OPERATING FLANGE WIDTH

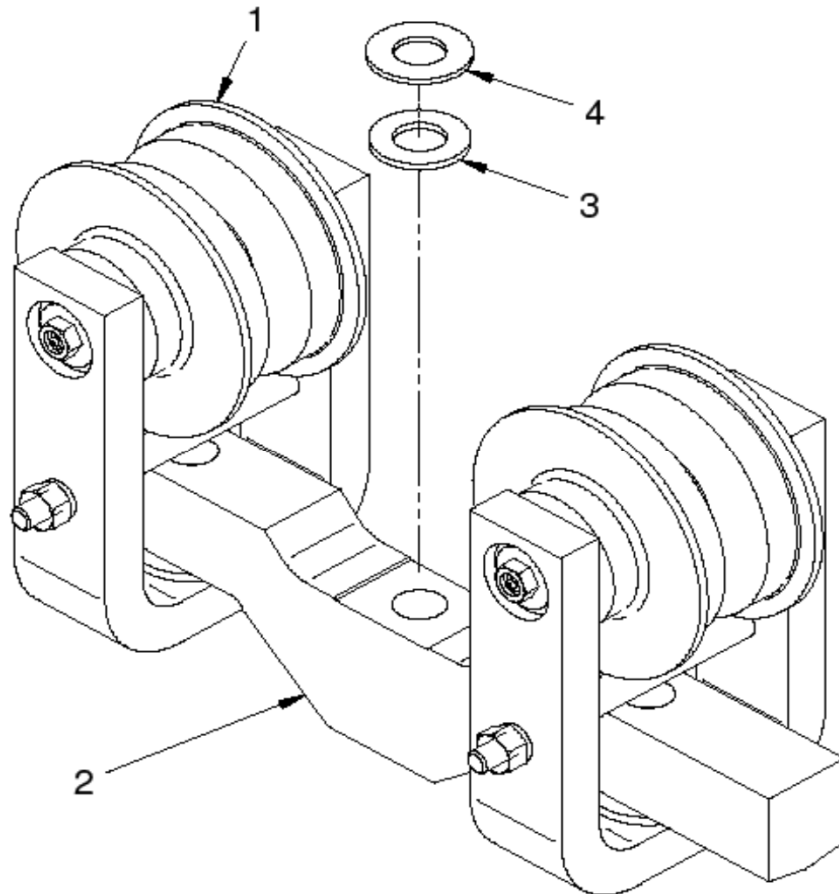

COMPLETE TROLLEY ASSEMBLY:
 Part No. 265178: 15,000 # trolley capacity

TROLLEY ASSEMBLY PARTS

ITEM NO.	PART NUMBER	DESCRIPTION	QTY
1 ▲	280314	Wheel Assembly, 6 1/2" diameter	2
2	260238	Loadbar	1
3 ▲	213613	Bearing, Thrust T-2304	1
4 ▲	210238	Washer	1

NOTE: ▲ Recommended spare parts

PARTS LIST - TROLLEY ASSEMBLY

**4-WHEEL MONORAIL TROLLEY ASSEMBLY
6 1/2" FLANGED WHEELS
15,000 # TROLLEY CAPACITY
3.25" AND 3.33" OPERATING FLANGE WIDTH**

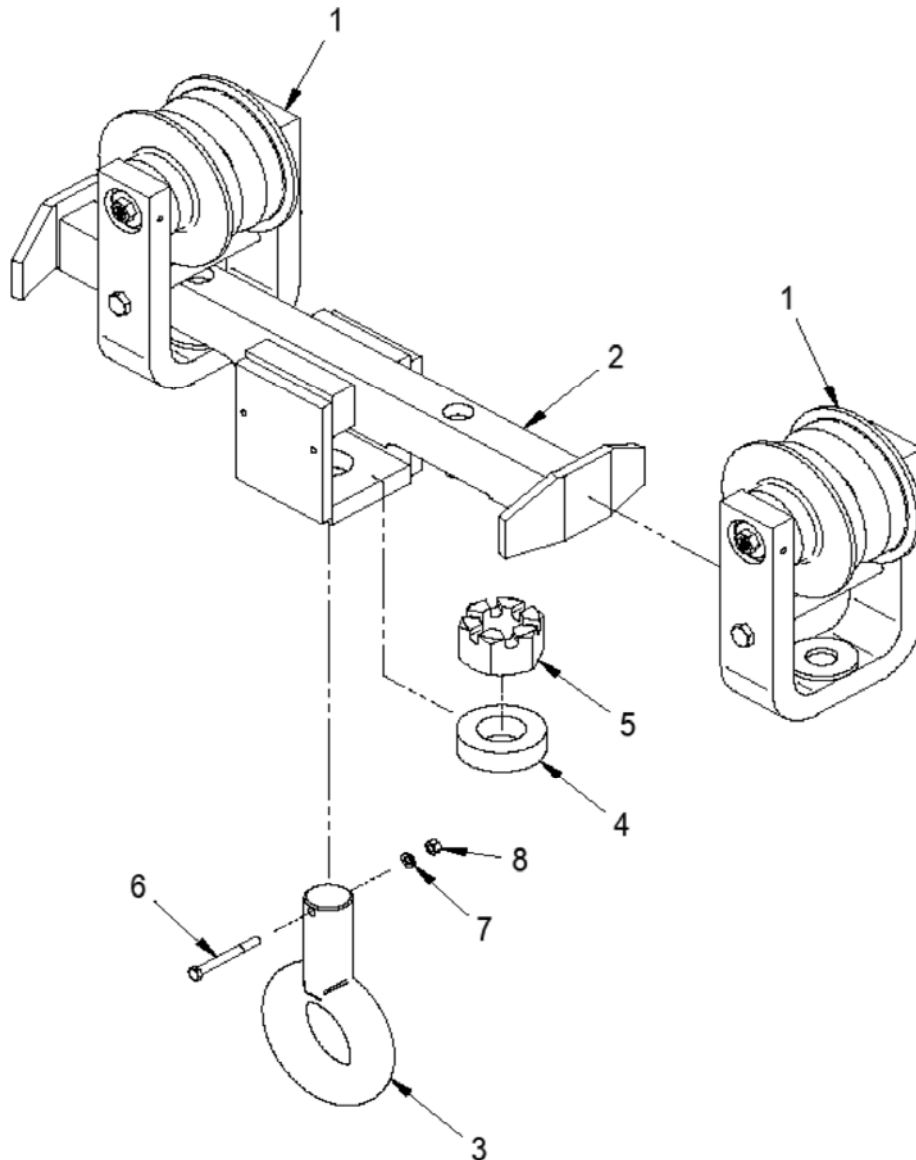

COMPLETE TROLLEY ASSEMBLY:
Part No. 301755: 15,000 # trolley capacity

TROLLEY ASSEMBLY PARTS

ITEM NO.	PART NUMBER	DESCRIPTION	QTY.
1 ▲	280314	2-Wheel Trolley	2
2	260337	Loadbar	1
3 ▲	300498	Eye Fitting	1
4 ▲	213532	Thrust Bearing	1

ITEM NO.	PART NUMBER	DESCRIPTION	QTY.
5 ▲	211994	Slotted Hex Nut	1
6	210873	Screw	1
7	210407	Lockwasher	1
8	211547	Hex Nut	1

▲ Recommended spare parts

PARTS LIST - TROLLEY ASSEMBLY

2-WHEEL TRAMBEAM™ HEAVY RAIL TROLLEY ASSEMBLY
6 1/2" FLANGELESS WHEELS AND SIDE GUIDE ROLLERS
7,500 # TROLLEY CAPACITY
3.25" OPERATING FLANGE WIDTH

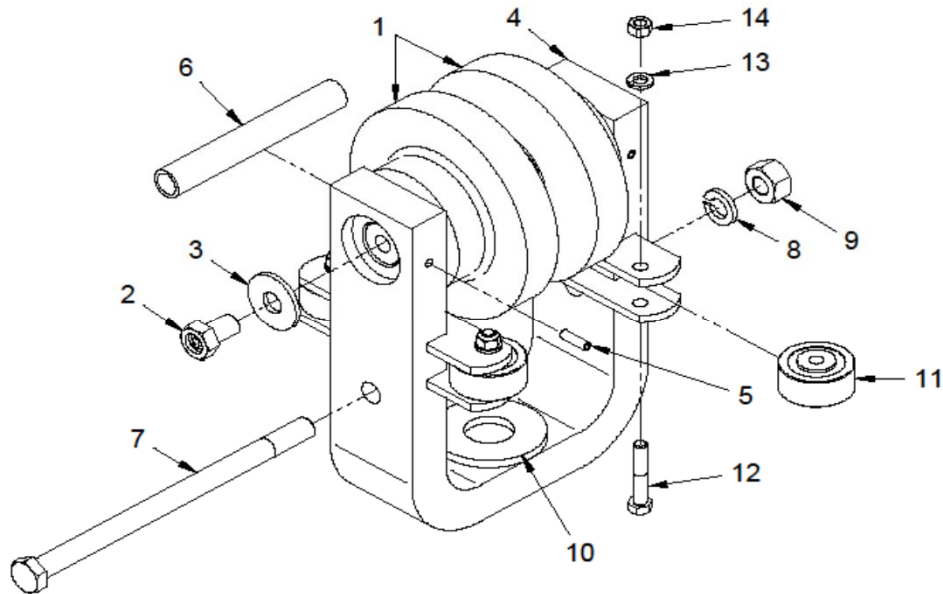

COMPLETE TROLLEY ASSEMBLY:
 Part No. 280312: 7,500 # trolley capacity

TROLLEY ASSEMBLY PARTS

ITEM NO.	PART NUMBER	DESCRIPTION	QTY
1 ▲	280359	Wheel Assembly, 6 1/2" Dia. FLSS for 7,500 LB. Cap. Trolley	2
2 •	260049	Screw Lube Assembly	2
3 •	260434	Washer	2
4	260837	Yoke, Trolley	1
5	210021	Pin, Roll	2
6	260225	Spacer, Yoke	1
7	210907	Bolt, Spacer	1
8	210410	Lockwasher	1
9	211661	Nut, Hex	1
10 ▲	260801	Bearing, Thrust	1
11 ▲	210050	Guide Roller	4
12	210868	Screw, Hex Head	4
13	210407	Lockwasher	4
14	211547	Nut, Hex	4

NOTE: ▲ Recommended spare parts
 • Included with item no. 1 but also available as a spare part.

PARTS LIST - TROLLEY ASSEMBLY

WHEEL TRAMBEAM™ HEAVY RAIL CRANE TROLLEY ASSEMBLY
 6 1/2" FLANGELESS WHEELS AND SIDE GUIDE ROLLERS
 15,000 # TROLLEY CAPACITY
 3.25" OPERATING FLANGE WIDTH

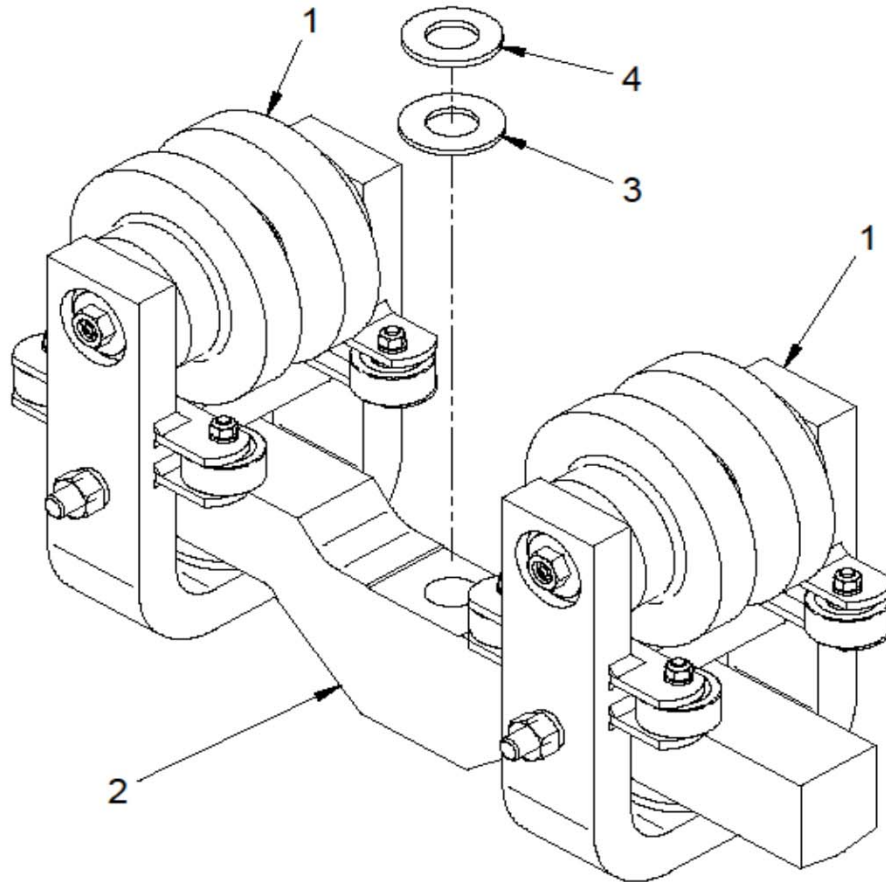

COMPLETE TROLLEY ASSEMBLY:
 Part No. 265177: 15,000 # trolley capacity

TROLLEY ASSEMBLY PARTS

ITEM NO.	PART NUMBER	DESCRIPTION	QTY
1 ▲	280312	Wheel Assembly, 6 1/2" diameter	2
2	260238	Loadbar	1
3 ▲	213613	Bearing, Thrust T-2304	1
4 ▲	210238	Washer	1

NOTE: ▲ Recommended spare parts

PARTS LIST - TROLLEY ASSEMBLY

4-WHEEL TRAMBEAM™ HEAVY RAIL MONORAIL TROLLEY ASSEMBLY
6 1/2" FLANGELESS WHEELS AND SIDE GUIDE ROLLERS
15,000 # TROLLEY CAPACITY
3.25" OPERATING FLANGE WIDTH

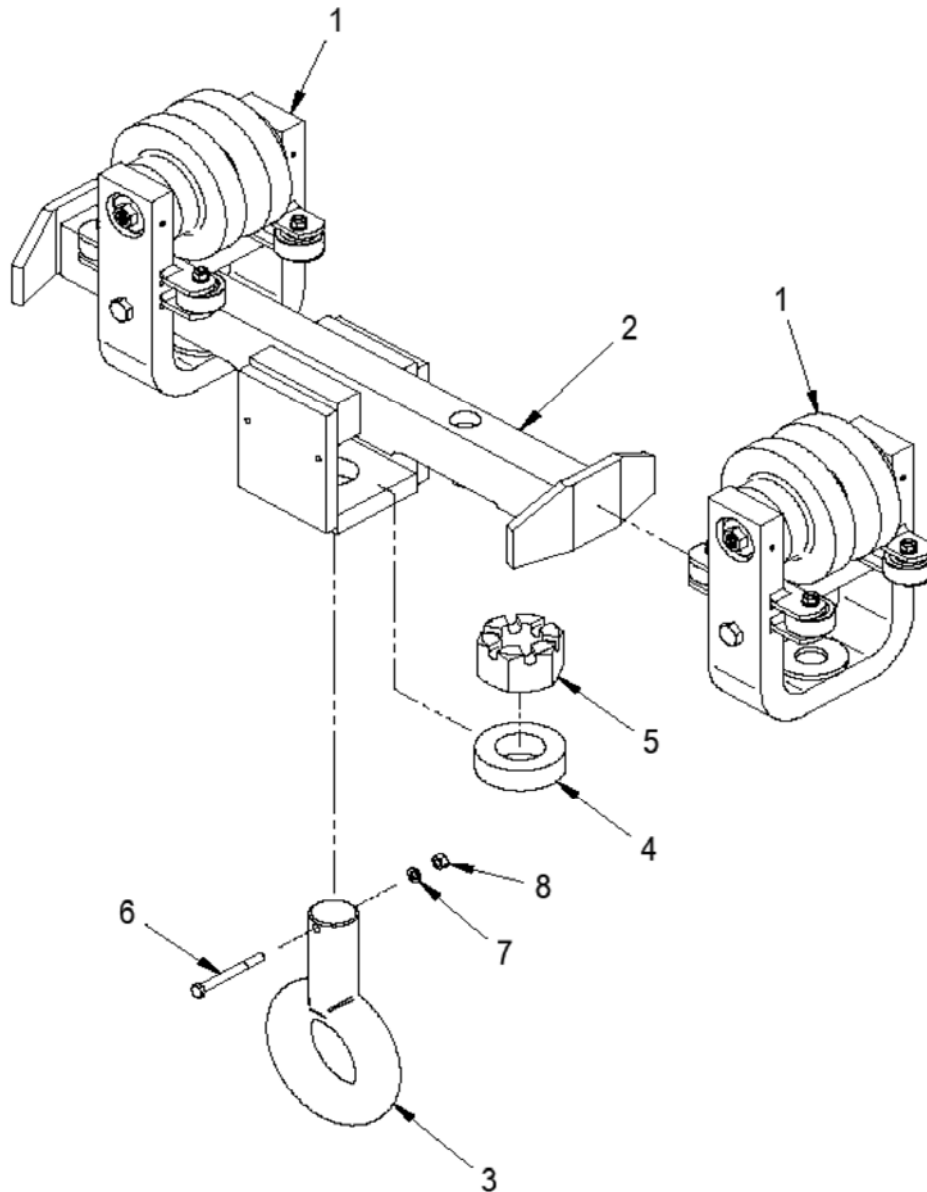

COMPLETE TROLLEY ASSEMBLY:
 Part No. 301754: 15,000 # trolley capacity

TROLLEY ASSEMBLY PARTS

ITEM NO.	PART NUMBER	DESCRIPTION	QTY.
1 ▲	280312	2-Wheel Trolley	2
2	260337	Loadbar	1
3 ▲	300498	Eye Fitting	1
4 ▲	213532	Thrust Bearing	1

ITEM NO.	PART NUMBER	DESCRIPTION	QTY.
5 ▲	211994	Slotted Hex Nut	1
6	210873	Screw	1
7	210407	Lockwasher	1
8	211547	Hex Nut	1

▲ Recommended spare parts

PARTS LIST - TROLLEY ASSEMBLY

2-WHEEL TROJANTRACK™ TROLLEY ASSEMBLY 6 1/2" FLANGELESS WHEELS AND SIDE GUIDE ROLLERS 7,500 # TROLLEY CAPACITY 3.33" OPERATING FLANGE WIDTH

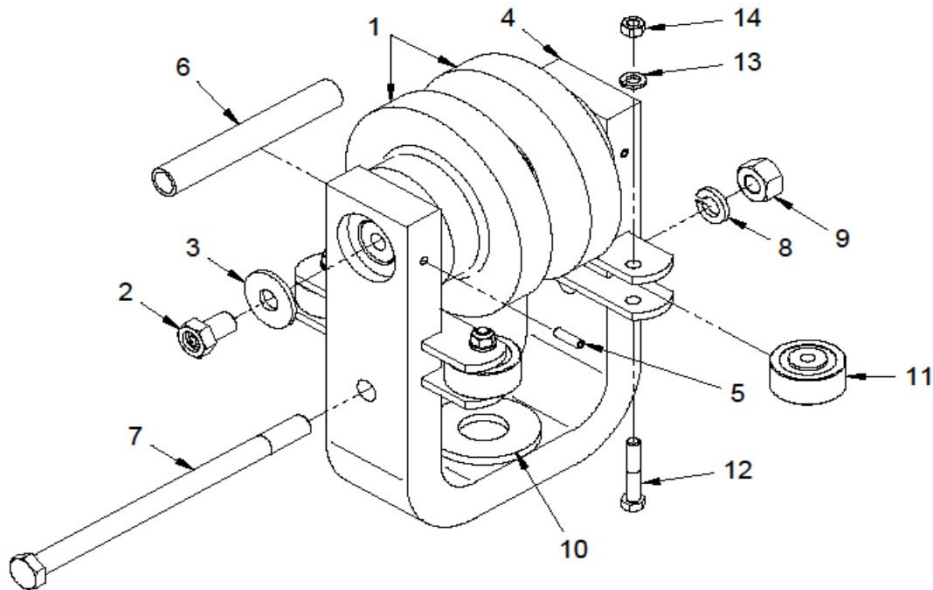

COMPLETE TROLLEY ASSEMBLY:
Part No. 280310: 7,500 # trolley capacity

TROLLEY ASSEMBLY PARTS

ITEM NO.	PART NUMBER	DESCRIPTION	QTY
1 ▲	280359	Wheel Assembly, 6 1/2" Dia. FLSS for 7,500 LB. Cap. Trolley	2
2 •	260049	Screw Lube Assembly	2
3 •	260434	Washer	2
4	260837	Yoke, Trolley	1
5	210021	Pin, Roll	2
6	260225	Spacer, Yoke	1
7	210907	Bolt, Spacer	1
8	210410	Lockwasher	1
9	211661	Nut, Hex	1
10 ▲	260801	Bearing, Thrust	1
11 ▲	213674	Guide Roller	4
12	210868	Screw, Hex Head	4
13	210407	Lockwasher	4
14	211547	Nut, Hex	4

NOTE: ▲ Recommended spare parts
• Included with item no. 1 but also available as a spare part.

PARTS LIST - TROLLEY ASSEMBLY

4-WHEEL TROJANTRACK™ CRANE TROLLEY ASSEMBLY
6 1/2" FLANGELESS WHEELS AND SIDE GUIDE ROLLERS
15,000 # TROLLEY CAPACITY
3.33" OPERATING FLANGE WIDTH

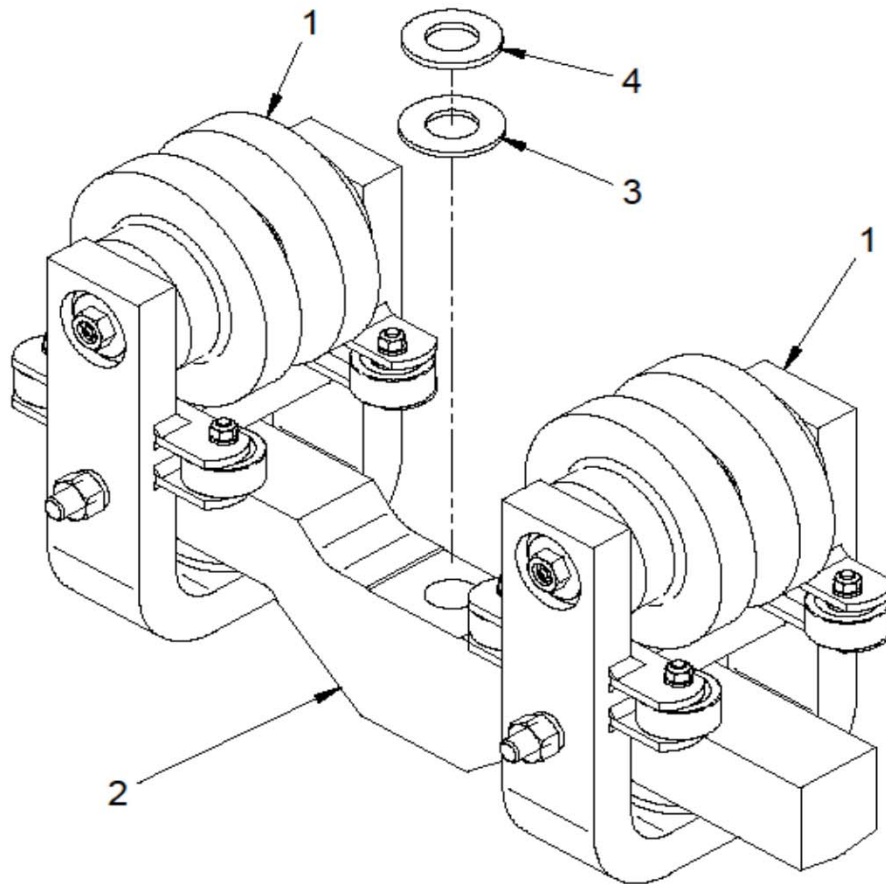

COMPLETE TROLLEY ASSEMBLY:
 Part No. 265176: 15,000 # trolley capacity

TROLLEY ASSEMBLY PARTS

ITEM NO.	PART NUMBER	DESCRIPTION	QTY
1 ▲	280310	Wheel Assembly, 6 1/2" diameter	2
2	260238	Loadbar	1
3 ▲	213613	Bearing, Thrust T-2304	1
4 ▲	210238	Washer	1

NOTE: ▲ Recommended spare parts

PARTS LIST - TROLLEY ASSEMBLY

**4-WHEEL TROJANTRACK™ MONORAIL TROLLEY ASSEMBLY
6 1/2" FLANGELESS WHEELS AND SIDE GUIDE ROLLERS
15,000 # TROLLEY CAPACITY
3.33" OPERATING FLANGE WIDTH**

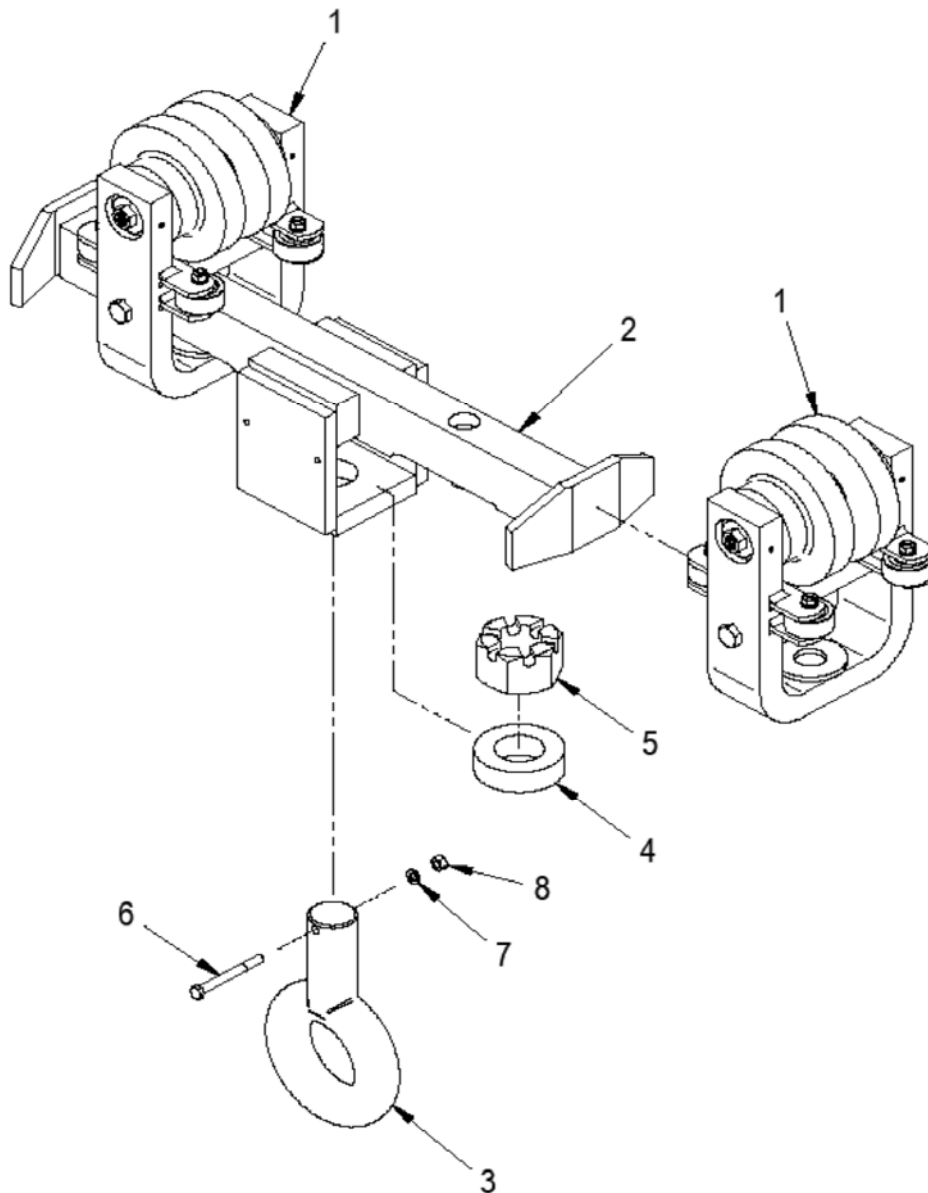

COMPLETE TROLLEY ASSEMBLY:
Part No. 301753: 15,000 # trolley capacity

TROLLEY ASSEMBLY PARTS

ITEM NO.	PART NUMBER	DESCRIPTION	QTY.
1 ▲	280310	2-Wheel Trolley	2
2	260337	Loadbar	1
3 ▲	300498	Eye Fitting	1
4 ▲	213532	Thrust Bearing	1

ITEM NO.	PART NUMBER	DESCRIPTION	QTY.
5 ▲	211994	Slotted Hex Nut	1
6	210873	Screw	1
7	210407	Lockwasher	1
8	211547	Hex Nut	1

▲ Recommended spare parts