

VAC-U-LIFT®

PRODUCT SERIES 7600

operation maintenance and parts manual

WARNING

This Vac-U-Lift should not be installed, operated, or maintained by any person who has not read all the contents of these General Instructions. Failure to read and comply with these instructions or any one of the limitations noted herein can result in serious physical injury and/or property damage.

SERIAL NUMBER
MODEL NUMBER

TABLE OF CONTENTS

<i>Instructions</i>	<i>Page</i>
BEFORE OPERATING	1
OPERATING INSTRUCTIONS	2
PERIODIC MAINTENANCE	2
EQUIPMENT DESCRIPTION	3
TROUBLE SHOOTING AND REPAIRS	6
TROUBLE SHOOTING GUIDE	7
RECOMMENDED SPARE PARTS & PARTS LISTS	10
RECOMMENDED LUBRICATING OILS	13

NOTE

These general instructions deal with the normal installation, operation and maintenance situations encountered with the Acco Vac-U-Lift. The instructions should not be interpreted to anticipate every possible contingency.

Record Serial Number and Model Number of the Vac-U-Lift on front cover of this manual for identification to avoid referring to the wrong manual for information or instructions.

User should use only Acco authorized replacement parts in the service and maintenance of this Vac-U-Lift.

WARNINGS

Equipment described herein is not designed for and should not be used for lifting, supporting or transporting humans.

User should not use this Vac-U-Lift in conjunction with other equipment unless necessary and/or required safety devices applicable to the system are installed by the user.

Modifications to upgrade, rerate or otherwise alter this Vac-U-Lift shall be authorized only by the original equipment manufacturer or qualified professional engineer.

Failure to comply with any one of the limitations noted herein may result in serious bodily injury.

This manual includes part pages and instructions for a variety of Vac-U-Lifts. Therefore all instructions and all parts pages do not apply to any one specific Vac-U-Lift. Disregard those parts and portions of the instructions which do not apply. If additional information is required contact :

Parts Department
 Acco Chain & Lifting Products Division
 76 Acco Drive, Box 792
 York, PA 17405-0792
 Phone: 800-967-7333
 Fax: 717-741-8572



7600 SERIES VAC-U-LIFT

INSTALLATION, OPERATION, AND MAINTENANCE INSTRUCTIONS

NOTE

It is the responsibility of the owner/user to install, inspect, test, maintain, and operate the Vac-U-Lift in a safe manner. The following pages contain rules for safe operation of a Vac-U-Lift. Taking precedence over any specific rule listed here, however, is the most important rule of all —“USE COMMON SENSE.” A few minutes spent reading these instructions can make an operator aware of dangerous practices to avoid, and precautions to take for his own safety and the safety of others. A regular schedule of inspection of the Vac-U-Lift should be established and records maintained.

BEFORE OPERATING

1. Your Vac-U-Lift should be checked on arrival for shipping damage. Report any such damage to the carrier's agent immediately.
2. Your unit may have been disassembled for shipping. It should be reassembled and checked for loose clamps, vacuum hoses, nuts and bolts.
3. Prior to putting the Vac-U-Lift unit in routine operation, read the operating instructions and perform the Proof Load Test described on page 2.
4. Connect the power cord to an outlet supplying the proper voltage, phase and cycle; check nameplate on unit for proper voltage, phase and cycle. Any extension power cord used should be of the grounding type to insure operator safety and should be heavy enough to carry the amperes drawn by the Power Pac without excessive voltage drop.
5. If the Power Pac unit is extremely cold, bring it to room temperature before attempting to start it.
6. Open access door on top of Power Pac, check oil level in oil reservoir and fill if necessary. Use of the correct oil and the proper amount of oil is important. For installations in warm climates or where room temperatures are high, increase viscosity equivalent to SAE 20. For installations below freezing, dilute oil with one-fourth kerosene. Re-using oil is not recommended.

Do not fill above equalizer hole in reservoir's stem. If oil enters stem, allow pump to operate several minutes before replacing cap or an air lock may develop in the reservoir and, therefore, oil would not flow to pump.

Both bearings and vanes are lubricated from this oil reservoir. Do not allow pump to operate dry as this may damage vanes or pump body.

7. Open access door on side of Power Pac; locate rotation direction arrow on vacuum pump. Press START/STOP switch on control panel and check rotation of pump. Stop pump and correct if necessary by reversing the wires in the electric outlet receptacle. Check rotation of pump after correction if it was necessary.

DO NOT Store your Vac-U-Lift unit for any appreciable length of time by allowing it to rest on the vacuum pad seals. To do so will shorten the life of the seal rings. The unit must be supported by the load beam or lifting yoke.

CAUTION: If for any reason there is a loss of power or the Vac-U-Lift is not operating properly the load should be lowered immediately.

CAUTION: If unit is moved to a different location, check pump rotation.

Operating Instructions

1. Position the pads to support the load evenly, then lower the unit onto the material to be lifted.
2. Turn unit on by pressing START/STOP button on control panel. The red indicator lamp should light.
3. Check the Power Pac for excessive noise or vibration. If the vacuum pump fails to start or if it hums loudly, stop the unit by pulling START/STOP switch on the control panel and refer to the troubleshooting section of the manual.
4. If your unit is equipped with hand-operated shut-off valves at each pad, BE CERTAIN to open enough of them to provide sufficient lifting capacity for the intended load. If all of the valves are closed, the red and green indicator lights will give a false indication.
5. Push the START/STOP button on control panel and push the VACUUM button on the control pendant. The vacuum gauge on the control panel will now indicate the system vacuum level in inches of mercury (Hg). The gauge reading will begin to rise. When the vacuum reaches 21" Hg, the green lamp will light. As soon as the green lamp lights, the load may be safely lifted and moved. The gauge reading should continue to increase to 25" Hg or more.
6. When the load has been lowered into its new position, push the VACUUM RELEASE button on the control pendant. The vacuum will be released and the red lamp will light indicating that the unit is ready to be raised and repositioned on the next load.

CAUTION: DO NOT attempt to lift if the green lamp does not come on even if the vacuum gauge indicates that an adequate vacuum level has been reached. The lights are a more reliable indication of sufficient vacuum than is the gauge.

Periodic Maintenance

Performing the following maintenance procedures will help prolong the life of your Vac-U-Lift and will assure you of the greatest possible operating safety. It is recommended that this schedule be followed as closely as possible.

Daily

Perform Proof Load Test.
Check oil reservoir and fill if necessary.

Weekly

Clean Vacuum filter and muffler.
Check seal rings, hoses and fittings.
Lubricate load beams and accessories, if required.
Check for loose bolts and nuts as well as structural damage.

Quarterly

Clean vacuum pump chamber by flushing.

Performing Proof Load Test

The Proof Load Test should be conducted daily to verify that the Vac-U-Lift safety features are operating properly.

- (1) Position the 7600 Series Litter over a sheet of non-porous material such as steel or aluminum. Adjust the crossarms and the vacuum pads to evenly distribute the weight of the load on each pad.
- (2) Lower the unit onto the material so that all pads make contact. All pad shut off valves should be set to the "vacuum on" position.
- (3) Start unit by pushing the START-STOP switch on control panel and push the VACUUM pushbutton on the control pendant.
- (4) Wait until the red lamp goes out and the green lamp lights, indicating that it is safe to lift the load. Note the reading of the vacuum gauge. It should stabilize at 25" Hg or greater.
- (5) Lift the vacuum unit and the material so that the load is between 1 and 2 inches above its rest position.
- (6) Simulate a power failure by pulling the START-STOP switch on the control panel. Observe the vacuum gauge. If the reading drops more than 1" Hg in two (2) minutes, there is a leak in the vacuum system. Lower load immediately and troubleshoot for leaks.

Flushing Vacuum Pump Chamber

After a period of time, foreign material will collect in the pump chamber. Periodic flushing of the pump will remove most of the trapped material.

To flush the pump of dirt, viscous oil, etc., remove the two hoses from the vacuum pump to the manifold at the manifold. While pump is running permit several teaspoons full of solvent to be drawn into pump at intake. After all the solvent has passed through the pump, immediately relubricate with a shot of oil and replace hoses. Recommended cleaning solvents are: Kerosene, Loctite Safety Solvent, Inhibisol Safety Solvent, and Dow Chemical Chlorothane.

Cleaning Filter and Muffler

It is important to keep both the filter and the muffler clean and in good condition to prevent dirt, moisture and oil vapor from entering the pump chamber.

The filter should be cleaned weekly whether or not it looks dirty. The condition of the filter can be checked by starting the vacuum pump and throwing the vacuum control switches to the VACUUM ON position with no material attached to the pads. The vacuum gauge should read less than 5" Hg. If the reading is higher, the filter element should be cleaned or replaced.

The felt elements of the filter and muffler may be cleaned by washing them in kerosene and blowing them dry with compressed air. The filter and muffler bowls should be washed in mild soap and water.

EQUIPMENT DESCRIPTION

7600 Series Lifter

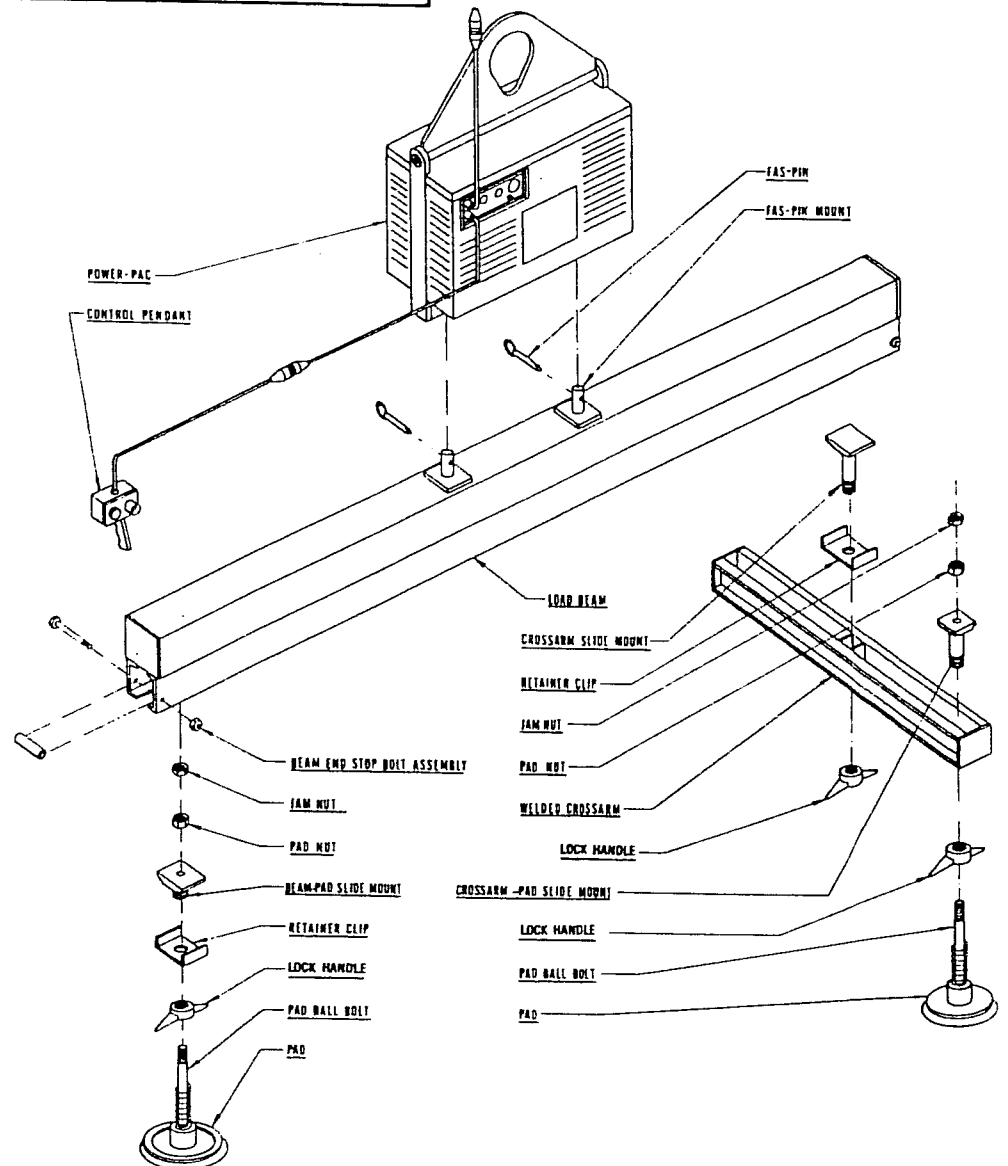
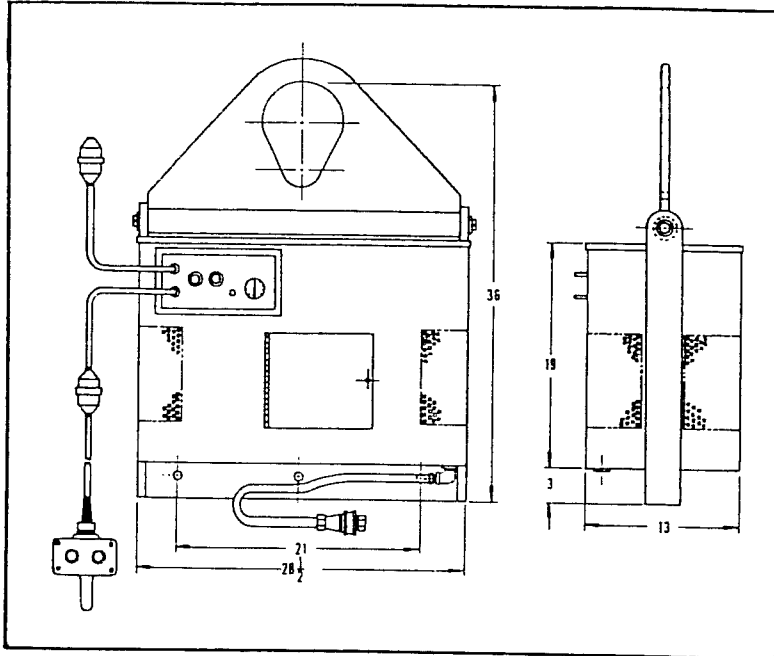

Power Pack

The Power Pac unit supplies and controls the vacuum used to attach the lifting pads to the load material. It houses a vacuum pump, vacuum reserve tank, the solenoid-operated main vacuum and vacuum reserve valves and the check valves, as well as the filter, muffler, and the main control panel with its indicators and switches.

The vacuum reserve system is a safety feature which prevents sudden loss of vacuum in the event of a power or equipment failure.

A push-pull, start-stop switch, red and green safety lights, which indicate whether sufficient vacuum has developed for safe lifting, a combination vacuum and pressure gauge to aid in checking performance of equipment and a fuse for the control circuit are mounted on the control panel.

Control Pendant

The control pendant houses a pushbutton, vacuum and vacuum release, to control solenoid-operated main vacuum valve. The vacuum release button is protected by a guard to prevent it from being actuated unintentionally.

Vacuum Lifting Pads

The configuration of the pad (or pads) is specified by the customer at the time of purchase. When more than one pad is used, they are connected in an array by means of a load beam and crossarms.

In multiple-pad configurations, vacuum lines connect all pads to the Power Pac. Hand-operated shut-off valves are included when it is necessary to disconnect certain pads from the vacuum circuit. These valves must be set as described in Step 4 of the Operating Instructions on page 2.

Operating Principals

The Vac-U-Lift is attached to the surface of the load by creating a partial vacuum over the area covered by the pads. Figure 1 depicts the system used to create and control the vacuum. The electrical control system is shown in Figures 2A, 2B, and 2C.

When the start button on the control panel is in the "on" position and the control pendant is on vacuum, the four-way control solenoid valve is de-energized allowing the vacuum pump to evacuate air from the pads through the filter, the control valve and the check valve. The pump vents the air to the atmosphere through the control valve and the muffler. The check valve prevents air from re-entering the pads should the vacuum pump stop, as in the case of a power failure.

At the same time that air is evacuated from the pads, it is also drawn from the vacuum reserve tank through a second check valve. The vacuum reserve solenoid valve is held in the closed position as long as electrical power is supplied to the unit. If the power is interrupted, however, the solenoid is de-energized, connecting the reserve tank directly to the pad vacuum lines. The vacuum in the pads is thereby

maintained for a period of several minutes until power is restored or the load is safely lowered.

To release the vacuum pads from the load once it has been positioned, the pendant control switch is thrown to the VACUUM RELEASE position, energizing the vacuum control solenoid valve. The valve then connects the pad vacuum line to the exhaust side of the vacuum pump and the muffler to the intake (vacuum) side of the pump. This process forces air to the vacuum pads releasing the vacuum and facilitating their removal from the load.

Because the check valve in the reserve tank line prevents air from flowing into the vacuum reserve tank during the release cycle, it is not necessary to re-evacuate the tank each time a load is lifted. The "Attach" time is therefore reduced to a minimum.

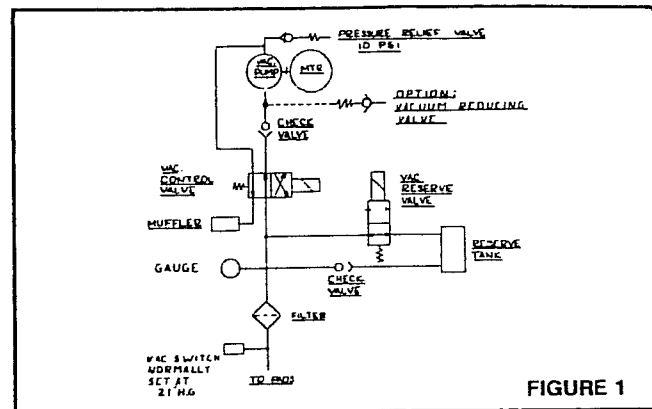

FIGURE 1

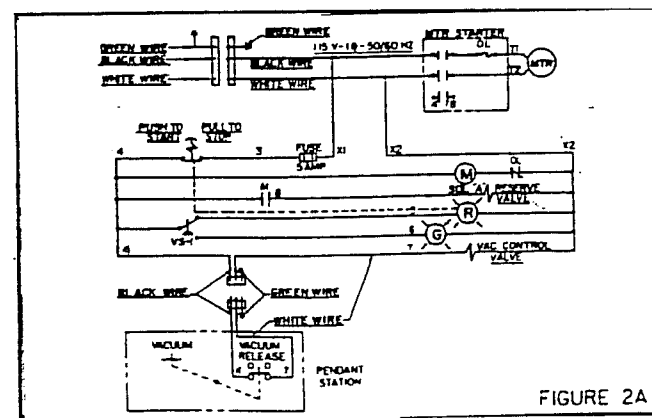

FIGURE 2A

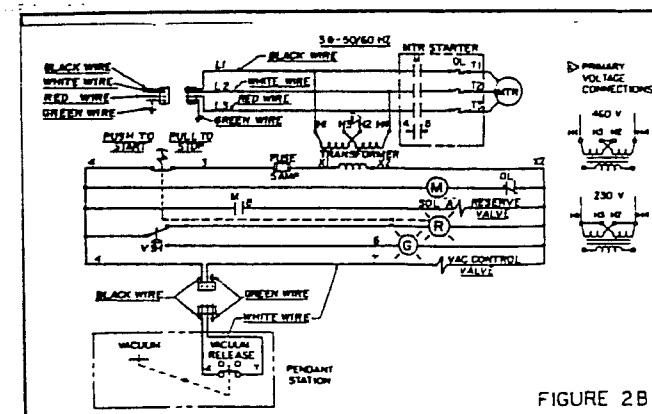
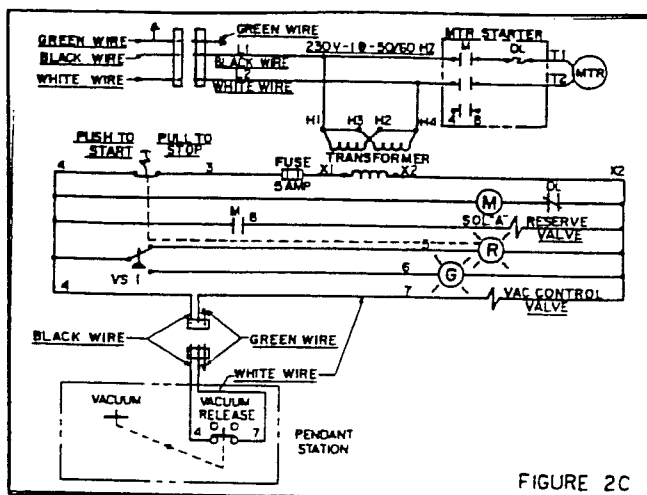

FIGURE 2B



1.0 Main Vacuum System

1.1 Vacuum Pump: The vacuum pump incorporated in your Vac-U-Lift is a rotary-vane, oil type pump. It is designed for continuous duty under full vacuum. Operating temperatures up to 230° F are normal.

The vacuum pump vanes are made of hard fiber and are precision ground. They should last 5,000 to 15,000 hours, depending upon the vacuum level at which the pump is run. Routine cleaning and checking of the filter and muffler as well as periodic flushing of the pump chamber will help prolong vane life (see the preceding section on periodic maintenance).

The four vanes can readily be replaced by removing the end plate shroud and exchanging new for worn or broken vanes. Use compressed air to clean out the pump chamber prior to inserting new vanes, especially if one of the old vanes has broken.

Sometimes when a vane breaks, a piece will wedge between the top of the rotor and the body, opening the top clearance. The clearance, which should be .004", may be checked with a feeler gauge. The rotor should be turned while the clearance is being checked so that all points of the circumference will clear. To reduce the top clearance to .004", tap VERY LIGHTLY on the top of the body with a miniature hammer.

Never remove the rotor. DO NOT loosen the bolts on either the body or mounting brackets as this will alter the preset clearance between the rotor and these parts.

1.2 Four-way Control Valve: The vacuum to the pads is controlled by a four-way solenoid valve which is manifold mounted.

As a safety feature, the valve is in the VACUUM ON position when the solenoid is de-energized. The valve is energized by the VACUUM RELEASE position on the control pendant. The exhaust air of the vacuum pump is then forced into the line to the pads supplying the air pressure required for a quick release.

1.3 Pressure Relief Valve: This valve is located on the exhaust side of the vacuum pump between the pump and the four-way control valve. Its purpose is to prevent pressure build-up at the pump. This condition can occur during the VACUUM OFF cycle if all of the pad valves are closed or if

the filter or vacuum line is clogged. This valve should not be set to release at a pressure greater than 10 psi.

1.4 Check Valve: One of the two check valves used in the Vac-U-Lift is located between the vacuum pump intake port and the four-way valve. It is installed so as to permit air to be pumped from the vacuum line system but to prevent air from entering the system when the vacuum pump is not running. This check is manifold mounted.

1.5 Filter and Muffler: The vacuum filter is located in the vacuum line between the pads and the four-way control valve. It prevents dirt and foreign matter from entering the vacuum pump and valves. The muffler serves two purposes. During the VACUUM ON cycle, it reduces the noise of the vacuum pump exhaust. In the VACUUM OFF condition, it filters the air entering the pump.

It is very important to keep both the filter and the muffler clean and in good condition to insure maximum system efficiency and long pump life. Instructions for filter and muffler maintenance may be found in the preceding section of periodic maintenance.

1.6 Three-way Hand-operated Shut-off Valves: Hand valves, located on or very near each vacuum pad, are provided when it is necessary to shut off certain pads from the circuit. In most cases, the valve is a three-way type so that the pad can be connected to either the vacuum system or an open port. This feature provides an escape for the slight vacuum formed in the pad when it is lowered onto the material and, thereby, prevents the unused pads from sticking to the load during the release cycle.

1.7 Vacuum Reducing Valve: This valve is located on vacuum side of pump and is set at 26" Hg. Its purpose is to prolong the useful life of the vacuum pump.

2.0 Vacuum Reserve System

2.1 Reserve Tank: The vacuum reserve system is provided to insure a source of vacuum to the pads for a reasonable length of time after a power or pump failure. The reserve tank is evacuated to full vacuum each time a load is lifted.

2.2 Check Valve: The second check valve in the Vac-U-Lift is connected between the vacuum reserve tank and the vacuum line system in such a way that air can be evacuated from the tank during the VACUUM ON cycle, but cannot re-enter the tank when the lines are pressurized during the VACUUM OFF cycle. The reserve tank, therefore, does not have to be completely evacuated each time a load is lifted, cutting down the length of time needed to attach the pad to the load.

2.3 Vacuum Reserve Valve: The check valve is paralleled by a solenoid-actuated two-way valve which is manifold mounted.

When energized, the valve is held in the closed position. The solenoid is fed directly from the vacuum pump power line so that in case electrical power to the vacuum pump is lost the valve will open, connecting the vacuum reserve tank to the pad vacuum circuit.

3.0 Control and Monitoring System

3.1 Switches: A PUSH-PULL, START-STOP switch is mounted on the control panel which starts and stops the unit. A VACUUM ON, VACUUM RELEASE switch is mounted in the control pendant which controls vacuum to the pads.

3.2 Fuses: A five (5) ampere fuse is mounted on the control panel. This protects the control circuit. Power for the vacuum reserve valve is fed through this fuse so that if the fuse blows, the reserve valve will open, connecting the vacuum reserve tank to the pad vacuum line.

3.3 Indicator Lights, Vacuum Switch and Vacuum Gauge: Both a vacuum gauge and a pair of indicator lights are provided to indicate the vacuum level. The vacuum gauge serves as a diagnostic instrument during testing and maintenance of the unit and provides a means of checking vacuum level during a power failure.

The red and green indicator lights are actuated by a vacuum switch connected to the pad vacuum line. When the vacuum level reaches 21" Hg, the vacuum switch disconnects the red light from the power line and connects the green light to indicate that sufficient vacuum has developed for lifting.

The vacuum switch, shown in Figure 3, may be adjusted, if necessary, to switch the lights at the correct vacuum level. Adjustment is made by turning the nut which has been indicated with an arrow in the drawing.

Before adjusting the switch, remove the vacuum filter element. A partially plugged filter will cause the gauge to indicate a higher vacuum level than that at the vacuum switch. If adjusted under this condition, the switch will trip at a level which is too low for sufficient capacity to lift the load.

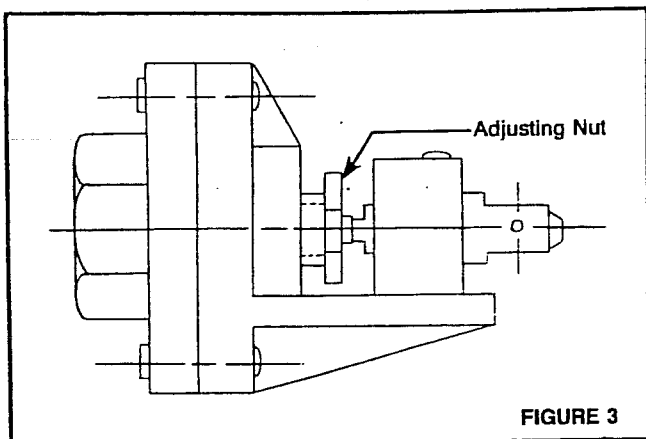

FIGURE 3

Troubleshooting and Repairs

Troubleshooting is always easier if one has a good understanding of how the equipment is intended to operate. A review of the Vac-U-Lift operating principles can be found on page 4. Piping and wiring diagrams, which should be useful in servicing this unit, are also shown.

1.0 Testing For Leaks

To insure safety, a Proof Load Test (see page 2) should be

performed on your Vac-U-Lift daily. If it fails, there is a leak somewhere in the vacuum system.

The location of the leak can most readily be determined by a process of elimination. The Power Pac itself is checked first; if it tests good, other sections of the vacuum system are connected one-at-a-time until the leaky section is found.

Disconnect the vacuum hose connecting the Power Pac to the load beam (or the vacuum pad in single pad systems). Insert a plug in the open port leading to the vacuum power unit. Perform the power-off vacuum test in the same manner as outlined for the Proof Load Test: start the pump, switch the vacuum on and allow the gauge reading to increase to 25" Hg or higher. Then, stop the pump and observe the gauge. If the reading drops more than 1" Hg in two minutes, the leak is located in the Power Pac. If not, the leak is in the piping to the vacuum pads or in the pads themselves.

If the leakage is in the external piping, reconnect the hose to the load beam assembly. Disconnect the hose leading to one end of the assembly and plug the open end. Repeat the power-off vacuum test. If leakage is still indicated, the leak is in the end of the load beam assembly just tested. If not it is in one of the pads or crossarms of the end which has been disconnected. Continue the process of elimination until the location of the leak is pinpointed.

The following components should be checked as possible sources of vacuum leaks:

- 1) Seal rings—Check for cracks, cuts or other damage.
- 2) Vacuum pads—Check for cracks and loose bolts.
- 3) Vacuum hoses—Check for breaks, cuts or pinch marks.

2.0 Tracing Power Pac Vacuum Leaks

If the tests have shown that leakage is occurring within the Power Pac itself, the same process of elimination may be used to trace the problem to its source. As before, a power-off vacuum test is performed as each portion of the vacuum system is disconnected. Refer to the Power Pac drawings and parts list on page 11.

2.1 Filter Leak: The filter may sometimes leak because of a damaged or improperly positioned gasket between the body and the filter bowl. The pet cock should also be checked for tightness.

2.2 Check Valve: The check valve and the four-way control valve located between the vacuum pump and the filter can be tested by starting the pump and allowing full vacuum to build up. Stop the pump and place a hand over the open part of the muffler. If any vacuum draw can be felt, one of the two valves is defective. In most cases, the check valve will be at fault.

2.3 Threaded Connections: All threaded connections should be drawn up tight using pipe dope. Care should be taken to prevent pipe dope and other foreign materials from entering the vacuum system.

Troubleshooting Guide

Vac-U-Lift

NOTE: See procedure on testing for leaks described on page 9.

TROUBLE	CAUSE	REMEDY	See Paragraph Number Under Component Description
1. Vacuum pump will not run	1. No power to unit 2. Blown fuse 3. Defective on-off switch 4. Loose or damaged wiring 5. Defective pump 6. Defective motor 7. Unit extremely low temperature	1. Check power source voltage and frequency. 2. Check and replace if needed. 3. Check and replace if needed. 4. Make visual or meter check. 5. Check vacuum pump. 6. Check and replace if needed. 7. Bring unit to room temperature before starting.	3.2 3.1 1.1 1.1
2. Vacuum pump runs hot (above 230 degrees)	1. Excessive foreign matter in pump 2. Worn vanes 3. Pump vanes hanging up 4. Low incoming voltage	1. Flush pump assembly. Replace vanes if necessary. 2. Replace vanes. 3. Check vanes and replace if necessary. Flush pump assembly. 4. Check and correct as required.	1.1 1.1 1.1
3. No or low vacuum reading on vacuum gauge	1. Improper vacuum pad seal 2. Clogged filter or muffler 3. Damaged vacuum pad or seal rings 4. Defective gauge 5. Loose or damaged hoses or fittings 6. Clogged vacuum lines 7. Clogged or damaged gauge line 8. Porous material 9. Defective 4-way control valve 10. Pump vanes hanging up 11. Defective pump 12. Loose Vacuum reducing valve	1. Make visual check. 2. Check, clean or replace as required. 3. Make visual check. 4. Check or replace as required. 5. Make visual check and repair or replace as required. 6. Check and clean as required. 7. Check, clean or replace as required. 8. Check unit on non-porous material such as steel, aluminum. 9. Check, clean or replace as required. 10. Flush pump assembly. Replace vanes, if necessary. 11. Replace or repair. 12. Reset to 26" Hg.	1.5 3.3 1.2 1.1 1.1 1.7

TROUBLE	CAUSE	REMEDY	See Paragraph Number Under Component Description
4. Red lamp will not light	1. Burned out bulb	1. Check and replace, if needed.	3.3
	2. Blown fuse	2. Check and replace, if needed.	3.2
	3. Defective vacuum switch	3. Check and replace as required.	3.3
	4. Loose or damaged wiring	4. Check and replace as required.	
	5. Vacuum switch not properly adjusted	5. Check and adjust as needed.	3.3
5. Green lamp will not light	1. Burned out bulb	1. Check and replace, if needed.	3.3
	2. Blown fuse	2. Check and replace, if needed.	3.2
	3. Defective vacuum switch	3. Check and replace, as required.	3.3
	4. Loose or damaged wiring	4. Check and replace as required.	
	5. Vacuum switch not adjusted properly	5. Check and adjust as needed.	3.3
	6. Unit remained on "Vacuum Off" cycle	6. (See Trouble No 7) Unit remains on "Vacuum Off" cycle.	
	7. All items listed under: "3. No or low vacuum reading on vacuum gauge" (except items No. 4 and No. 7)		
6. Unit remains in "Vacuum On" cycle	1. Blown fuse	1. Check and replace if needed.	3.2
	2. Loose or damaged wiring	2. Check and replace as required.	
	3. Defective 4-way control valve coil	3. Check and replace as required.	1.2
	4. 4-way control valve hanging up	4. Check, clean or replace as required.	1.2
	5. Defective vacuum on-off pushbuttons	5. Check and replace as required.	
7. Unit remains in "Vacuum Off" cycle	1. Vacuum on-off switch left in the "Vacuum Off" position	1. Switch to the vacuum on position.	
	2. 4-way control valve hanging up	2. Check, clean or replace as required.	1.2
	3. Defective vacuum on-off pushbuttons	3. Check and replace as required.	
	4. Short in wiring	4. Check and correct.	
8. Excessive attach time	1. Clogged filter or muffler	1. Check, clean or replace as required.	1.5
	2. Improper vacuum pad seal	2. Make visual check.	
	3. Damaged vacuum pad or seal rings	3. Check for cracks, loose or broken bolts, cut or torn seal rings, or excessive seal ring wear.	
	4. Clogged, loose or damaged hoses or fittings	4. Clean or replace as required.	

TROUBLE	CAUSE	REMEDY	See Paragraph Number Under Component Description
Excessive attach time (cont.)	5. Loose or damaged wiring on vacuum reserve valve 6. Defective vacuum reserve valve or check valve 7. Defective 4-way control valve 8. Vacuum pump vanes hanging up 9. Worn vacuum pump 10. Porous material	5. Check or replace as required. 6. Check, clean or replace as needed. 7. Check, clean or replace as required. 8. Check and replace vanes if necessary. Flush pump assembly. 9. Replace vanes or entire pump as needed. 10. Test unit on non-porous material such as steel or aluminum.	2.3 2.3 1.2 1.1 1.1
9. Excessive release time	1. Clogged filter or muffler 2. Clogged, loose or damaged hoses or fittings 3. Loose or damaged wiring on vacuum reserve valve 4. Defective vacuum reserve valve or check valve 5. Defective 4-way control valve 6. Vacuum pump vanes hanging up 7. Worn vacuum pump 8. Loose Pressure Relief	1. Check, clean or replace as required. 2. Make visual check. 3. Check or replace, as required. 4. Check, clean or replace as required. 5. Check, clean or replace as required. 6. Check vanes and replace if necessary. Flush pump assembly. 7. Check and replace vanes or entire pump as needed. 8. Replace or reset to 10 P.S.I	1.5 2.3 2.2 2.3 1.2 1.1 1.1
10. Unit blows fuse	1. Low incoming voltage 2. Short in the electrical circuit 3. Clogged filter or muffler 4. Pressure relief valve set above 10 P.S.I. 5. Vacuum pump freezing up	1. Check and correct as required. 2. Check and correct as required. 3. Check, clean or replace as required. 4. Check and adjust as required. 5. Check for broken vanes or foreign matter in assembly.	1.5 1.3 1.1
11. Excessive vacuum loss during a Proof Load Test Procedure		1. See proof Load Test Page 5	2.0
12. Noisy vacuum pump	1. Sticking vane	1. Allow pump to run for a short period. If noise continues, replace vane.	1.1

Recommended Spart Parts List of Power Pac

REF. NO.	DESCRIPTION	PART NO.	QTY.	REF. NO.	DESCRIPTION	PART NO.	QTY.
1	REPAIR KIT FOR VACUUM PUMP	26501	1	7	FUSE MOUNT ASSEMBLY	22498	1
2	VACUUM GAUGE	28609	1	8	FUSE MTH-5	22490	2
3	VACUUM SWITCH	22883	1	9	CHECK VALVE	27554	1
4	SWITCH START/STOP	22834	1	10	FILTER-MUFFLER ELEMENT	28463	4
5	GREEN LIGHT ASSEMBLY	22593	1	11	CONTROL VALVE-SOLENOID	27247	1
6	LIGHT BULB	22192	2	12	CONTROL VALVE-STEM & SEALS	27258	1

VACUUM PAD SEAL RINGS ARE ALSO RECOMMENDED AS SPARE PARTS—GIVE PAD SIZE WHEN ORDERING SEAL RING.

Control Pendant and Power Pac External Parts

REF. NO.	PART NO.	DESCRIPTION	QTY.
1	29113	Bail	1
2	29114	Bail Pin	1
3	28303	Cover	1
4	29111	Yoke	1
5	28404	Street Elbow	1
6	28930	Hose Stem	2
7	28398	Quick Disconnect Socket	1
8	28398	Quick Disconnect Plug	1
9	29183	Vacuum Hose 3/4" x 30"	1
10	28484	Fas-Pin	2
11	22730	Pendant Complete	1
12	22849	Push Button	1
13	22558	Thumb Guard	1
14	23848	Connector	1
15		Cable 14-3 x 42"	1
16		Cable 14-4 x 36" All other Voltages	1
17A	23841	Plug 115 Volt 1 Phase	1
17B	23854	Plug 230 Volt 1 Phase	1
17C	23843	Plug 230 Volt 3 Phase	1
17D	23845	Plug 460 Volt 3 Phase	1
18A	23842	Connector 115 Volt 1 Phase	1
18B	23855	Connector 230 Volt 1 Phase	1
18C	23844	Connector 230 Volt 3 Phase	1
18D	23846	Connector 460 Volt 3 Phase	1
19	28300	Cover Panel	1
20	22593	Light	1
21	22834	Push Button	1
22	22498	Fuse Mount	1
23	22490	Fuse 5 Ampere	1
24	28609	Vacuum Gauge	1
25	22005	Light Adapter	1
26	22192	Bulb	1

Power Pac Internal Parts

REF. NO.	PART NO.	DESCRIPTION	QTY.	REF. NO.	PART NO.	DESCRIPTION	QTY.
32	28987	Vacuum Tank	1	53	28908	Hose Stem 1/4" N.P.T. x 1/4"	4
33	27554	Check Valve	1	54	28406	Street Elbow 1/4" N.P.T.	4
34	28922	1/2" N.P.T. x 3/8" Hose Stem	2	55	29180	Vacuum Hose 1/4" x 12" Long	1
35	29199	Vacuum Hose 3/8" x 9-1/2" Long	1	56	22147	Cover	1
36	28409	1/2" N.P.T. Street Elbow	1	57	22150	Electrical Box	1
37	29183	Vacuum Hose 3/4" x 12" Long	1	58	57801-013	Cord Grip	1
38	61571	Manifold	1	59	90319	Conductor 3-No. 14x36" Long 115/230-1-60	1
39	61570	Manifold Gasket	1		90320	Conductor 3-No. 14x36" Long All Other Voltages	1
40	61572	Manifold Cover	1	60	31039	Motor 460-3-60	1
41	29505	Check Valve Gasket	1		31039	Motor 230-3-60	1
42	29502	Cover	1		31032	Motor 230-1-60	1
43	61020	Check Valve	1		31062	Motor 115-1-60	1
44	28930	Hose Stem 3/4" N.P.T. x 3/4"	6	61	29198	Vacuum Hose 1/4" x 18" Long	1
45	29183	Vacuum Hose 3/4" x 16" Long	1	62	29199	Vacuum Hose 3/8" x 7-1/2" Long	1
46	28404	Street Elbow 3/4" N.P.T.	2	63	28920	Hose Stem 3/8" N.P.T. x 3/8"	1
47	29183	Vacuum Hose 3/4" x 14-1/2" Long	1	64	28510	Filter	2
48	26429	Relief Valve	1	65	28115	Mounting Bracket	1
49	27789	Control Valve	1	66	31134	Vacuum Pump	1
51	61030	Valve Ass'y 115V AC	1	67	26193	Flexible Coupling	1
52	61031	Valve Ass'y 230V DC	1	68	90318	Conductor 2-No. 14 x 30" Long	1
				69	22328	Conduit Elbow 1/2" N.P.T. x 45 degrees	1
				70	57801-012	Cord Grip	1
				71	52429-20	Transformer (Not used on 115-1-60)	1
				72	22802	Motor Starter	1
				73	22980	Heater Coil 460-3-60	3
					22982	Heater Coil 230-3-60	3
					22984	Heater Coil 230-1-60	1
					22986	Heater Coil 115-1-60	1
				74	28609	Pressure Switch	1
				75	28700	1/4" All Thread	1
				76	22461	Bulkhead Fitting	1
				77	14978	Flexible Conduit 1/2 x 7-1/4" Long	1
				78	26430	Vac. Relief Valve	1

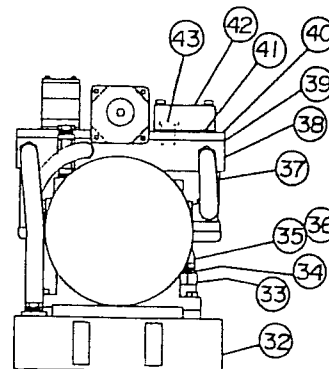
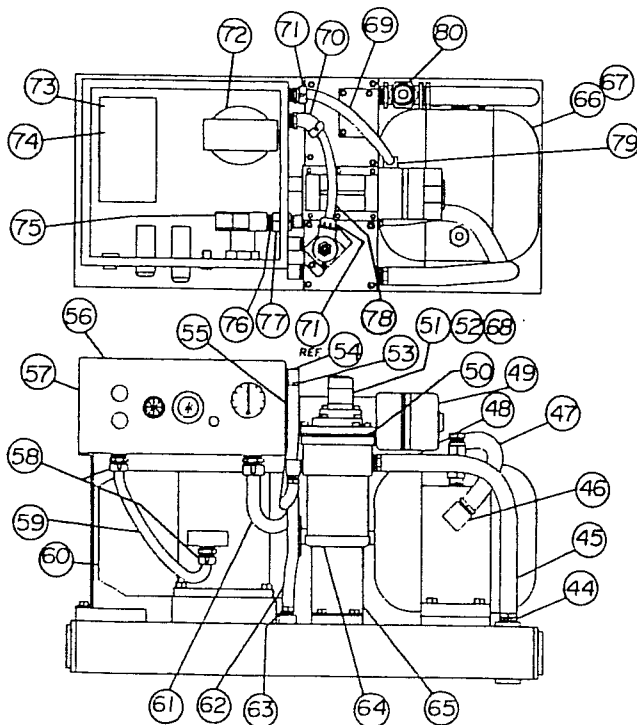

Vacuum Pump

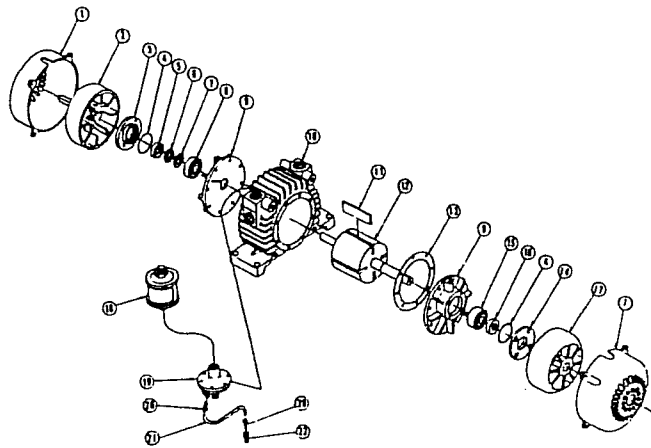

REF. NO.	PART NO.	DESCRIPTION	QTY.
0	31134	Complete Pump	1
1		Fan Guard	2
2		Fan, Dead End	1
3		End Cap, Dead End	1
4*		"O" Ring	2
5*		Shaft Seal, Dead End	1
6		Lock Nut	1
7		Lock Washer	1
8*		Bearing, Dead End	1
9		End Plate	2
10		Body	1
11*	26456	Vane	4
12	26332	Rotor Assembly	1
13*		Body (Spacer) Gasket	1
14		End Cap, Drive End	1
15*		Bearing, Drive End	1
16*		Shaft Seal, Drive End	1
17		Fan, Drive End	1
18	26316	Oil Reservoir	1
19	26263	Vacuum Lubricator	1
20		Compression Fittings	4
21		Oil Tube	2
22		Connector	2

* Repair Kit No. 26501 contains Items 4, 5, 8, 11 (Set of Vanes), 13, 15 and 16.

Filter-Muffler

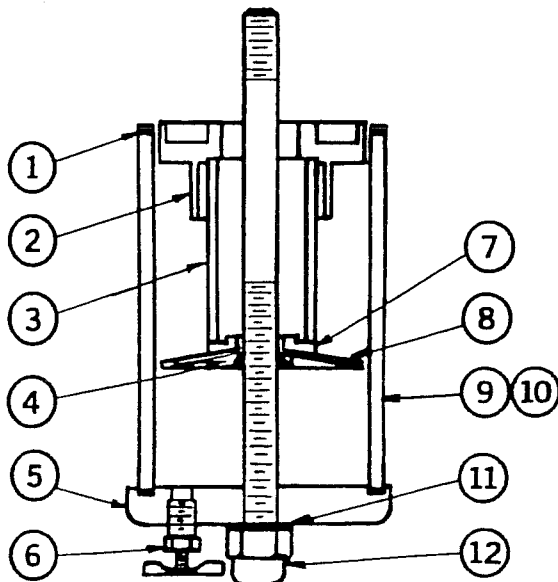

REF. NO.	PART NO.	DESCRIPTION	QTY.
0	28510	Filter Complete	1
1	28571	Gasket Bowl	2
2		Whirl Disc	1
3	28463	Element	1
4		Nut, Baffle	1
5		Base	1
6		Drain Assy.	1
7		Element Spacer	1
8		Baffle Plate	1
9	28108	Bowl	1
10		Bowl Guard	1
11		Stud Gasket	1
12		Base Nut	1

Vacuum Relief Valve

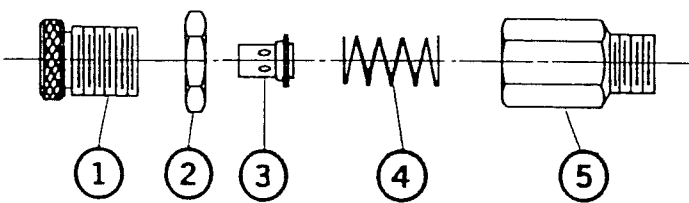

REF. NO.	PART NO.	DESCRIPTION	QTY.
0	26430	Valve Complete	1
1		Retainer	1
2		Nut	1
3		Seal	1
4		Spring	1
5		Body	1

Pressure Relief Valve

Spring

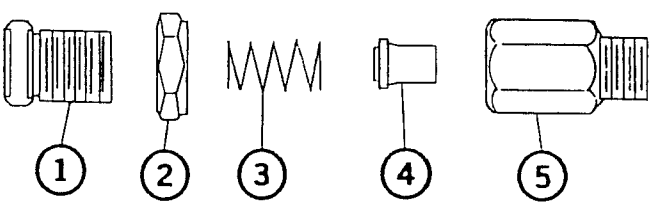

REF. NO.	PART NO.	DESCRIPTION	QTY.
0	26429	Valve Complete	1
1		Retainer	1
2		Nut	1
3		Spring	1
4		Seal	1
5		Body	1

Manifold Check Valve

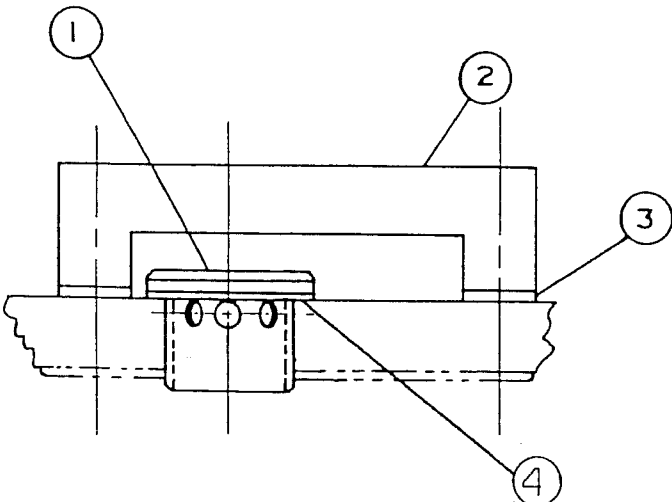

REF. NO.	PART NO.	DESCRIPTION	QTY.
1	61020	Check Valve	1
2	29502	Cover	1
3	29505	Check Valve Gasket	1
4	24470	Check Valve Seal	1

Recommended Lubricating Oils

	SAE No. 10 For Ambients Below 100 Degrees F	SAE No. 20 For Ambients Above 100 Degrees F
GAST	AD220	
AMERICAN	S-1 No. 10	S-1 No. 20
CITGO	C-310	C-320
GULF	Gulflube HD-10	Gulflube HD-20
HUMBLE	Encolube HDX-10	Encolube HDX-20
MOBILE	Delvac 1110	Delvac 1120
SHELL	Rotella No. 10	Rotella No. 20
SINCLAIR	Super TBT No. 10	Super TBT No. 20
SUN	Sunvis 610	Sunvis 620
TEXACO	URSA S-1 No. 10	URSA S-1 No. 20

4-Way Valve Parts

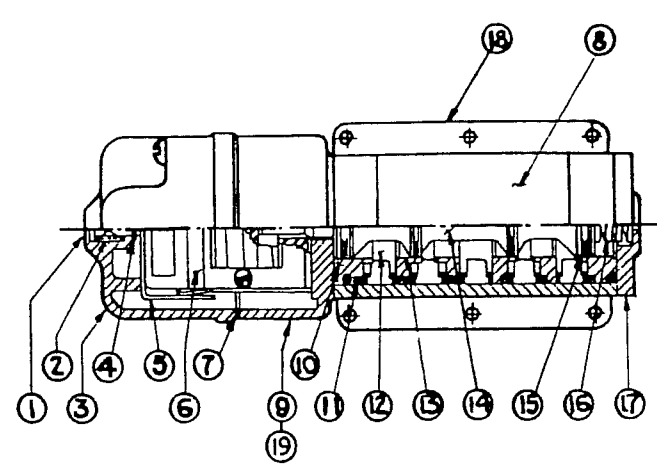

REF. NO.	PART NO.	DESCRIPTION	QTY.
0	27789	Valve complete	1
1		Manual Pushbutton	1
2		Pushbutton Spring	1
3		Sol. Cover Front	1
4		Snap Ring	1
5		Sol. Clip	1
6	27247	Solenoid	1
7		Cover Gasket	1
8		Valve Body	1
9		Sol. Cover Rear	1
10		Stem Guide	2
11		Static "O" Ring	8
12		Spacer	5
13		Valve Seat	4
14	27258	Valve Stem and Seals	1
15		Stem "O" Rings	2
16		Spring	1
17		End Cap	1
18	29504	Mtg. Gasket	1
19	70750	Coil	1

Vacuum Reserve Valve

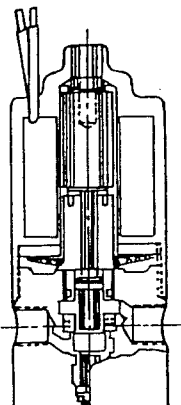

REF. NO.	PART NO.	DESCRIPTION	QTY.
0	61030	Valve Complete AC	1
	61031	Valve Complete DC	1
1		Adapter	1
2		Sleeve Nut	1
3		Housing Nut	1
4		Nameplate	1
5		Coil Housing	1
6	861295	Coil AC	1
	27086	Coil DC	1
7		Sleeve Assembly	1
8		Plunger Spring	1
9		Plunger	1
10		Flange Seal	1
11		Body	1

CV-3 Check Valve Parts

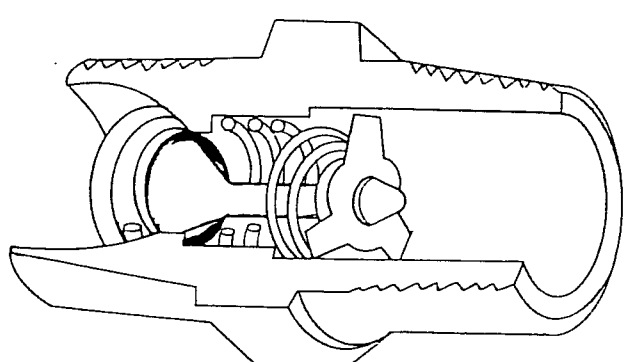

REF. NO.	PART NO.	DESCRIPTION	QTY.
0	27554	Complete Valve	1
1		Body	1
2		Poppet	1
3		Spring	1
4		Retainer	1
5		Snap Ring	1



Acco Chain & Lifting Products Division

76 Acco Drive, Box 792, York, PA 17405-0792
717-741-4863 800-967-7333 Fax 717-741-8572

© FKI Industries, Inc. 1996

Printed in U.S.A.